

U.S. Department of Housing and Urban Development
Office of Community Planning and Development



The Noise Guidebook

The Noise Guidebook

**A Reference Document for
Implementing the Department of
Housing and Urban Development's
Noise Policy**

**Prepared By The Environmental
Planning Division,
Office of Environment and Energy**

Table of Contents

| | |
|-----------|--|
| 1 | Chapter 1 Basic Overview of The Environmental Noise Problem |
| 9 | Chapter 2 The Noise Regulation |
| 19 | Chapter 3 Major Policy Questions |
| 21 | Chapter 4 Noise Attenuation |
| 43 | Chapter 5 Noise Assessment Guidelines |
| 79 | Chapter 6 Noise Assessment Guidelines Workbook |
| 99 | Chapter 7 The Use of Noise Measurements |

Preface

Introduction

This *Noise Guidebook* has been prepared to serve as the basic reference document for all HUD field staff who are responsible for implementing the Department's noise policy. It brings together in one place all the various reports, informational papers and other items that have been put out by the Department over the past several years. It also contains several new items designed to make your job easier.

This *Guidebook* is designed to serve not only the experienced HUD staff member but also the new employee or the old employee who is new to the noise field. Because of this, the *Guidebook* contains some fairly basic background material as well as quizzes and other material specifically geared for the "learner."

Chapter 1

Basic Overview of the Environmental Noise Problem

Introduction

Background

Definition and Scope of the Noise Problem

The air around us is constantly filled with sounds, yet most of us would probably not say we are surrounded by noise. What then is the difference between ordinary sound and what we call noise? The traditional definition of noise is that it is "unwanted sound." Sound becomes unwanted when it either interferes with our normal activities such as sleeping, conversation or recreation, when it causes actual physical harm such as hearing loss or has adverse effects on mental health. As we have become a more urbanized country and as technology has advanced, the level of sound in our environment has reached the point when it sometimes does cause interference and does cause physical and psychological harm, and thus we have developed a noise problem. (See Figure 1 for a listing of common sounds.)

The dimensions of the noise problem have grown larger and larger over the past few decades. In its 1979 Annual Report, The Council on Environmental Quality stated that "nearly half the US population is regularly exposed to levels of noise that interfere with ...normal activities" and about "1 in 10 ...are exposed to noises of duration and intensity sufficient to cause a permanent reduction in their ability to hear."

Figure 1
Common Sounds
Basic Theory: Common Sounds in Decibels (dB)

Some common, easily recognized sounds are listed below in order of increasing sound intensity levels in decibels. The sound levels shown for occupied rooms are typical general activity levels only and do not represent criteria for design.

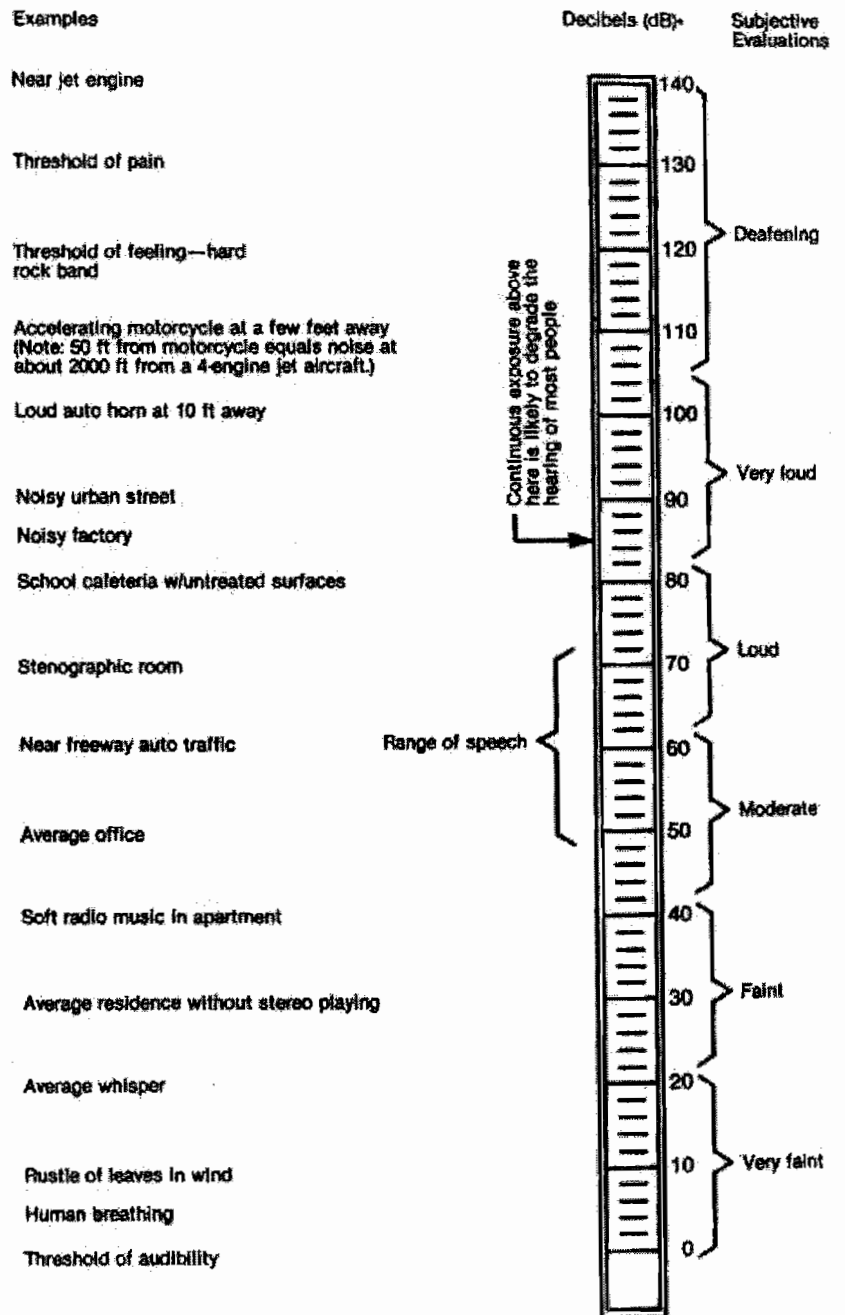

*dB are "average" values as measured on the A-scale of a sound-level meter
(From *Concepts in Architectural Acoustics*: M. David Egan, McGraw Hill, 1972.)

The Dynamics of the Noise Problem

There are basically two types of noise problems. There is the specific, job related, occupational noise problem created by extremely loud machinery. Then there is the community noise problem where the combined effect of many individual noise sources creates an overall noise level that is unacceptable. In the following pages we will be addressing the community noise problem only.

The main contributors to a community noise problem are transportation sources such as highways, railroads and airports. These sources are the most pervasive and continuing of the noise sources within the community. Of course, at any given site, there may be other noise sources which add to the problem, sources such as jackhammers at a construction site. But in general, and for the purposes of this section, the main concern is with the transportation sources.

The dynamics of a noise problem are based on the relationship between the noise source, the person or place exposed to the noise (hereafter called the receiver) and the path the noise will travel from source to receiver.

The source generates a given amount of noise which travels along the path and arrives at the receiver. The amount of noise will be reduced to some extent as a result of how long that path is or whether there are any barriers along the path. The severity of the impact on the receiver is a function of what type of activity is taking place, whether it is indoors or outdoors, and what type of building it is in if the activity is indoors. Figure 3 contains some basic compatibility guidelines.

The impact of the noise can be altered or mitigated by changing the characteristics of any of the three elements: source, path or receiver. Later on we will look at the various mitigation measures that are possible. Our concern however will be primarily with the receiver and the path. Control of the sources themselves is the specific responsibility of agencies such as the Environmental Protection Agency (EPA) or the Federal Aviation Administration (FAA).

Figure 2
Dynamics of a Noise Problem

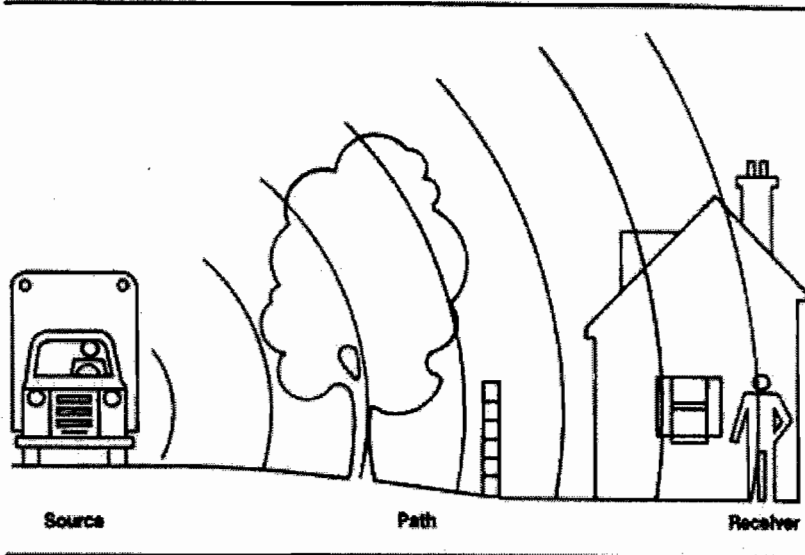

Figure 3
Land Use Compatibility Guidelines

| LAND USE CATEGORY | LAND USE INTERPRETATION FOR NEF VALUE* | | | |
|--|--|-----------------------|----------------------|----------------------|
| | 20 | 30 | 40 | 50 |
| Residential — Single Family, Duplex, Mobile Homes | | Normally Unacceptable | Clearly Unacceptable | Clearly Unacceptable |
| Residential — Multiple Family, Dormitories, etc. | | Clearly Unacceptable | Clearly Unacceptable | Clearly Unacceptable |
| Transient Lodging | | Clearly Unacceptable | Clearly Unacceptable | Clearly Unacceptable |
| School Classrooms, Libraries, Churches | | Clearly Unacceptable | Clearly Unacceptable | Clearly Unacceptable |
| Hospitals, Nursing Homes | | Clearly Unacceptable | Clearly Unacceptable | Clearly Unacceptable |
| Auditoriums, Concert Halls, Music Shells | Clearly Unacceptable | Clearly Unacceptable | Clearly Unacceptable | Clearly Unacceptable |
| Sports Arena, Outdoor Spectator Sports | | Clearly Unacceptable | Clearly Unacceptable | Clearly Unacceptable |
| Playgrounds, Neighborhood Parks | | Clearly Unacceptable | Clearly Unacceptable | Clearly Unacceptable |
| Golf Courses, Riding Stables, Water Rec., Cemeteries | | Clearly Unacceptable | Clearly Unacceptable | Clearly Unacceptable |
| Office Buildings, Personal, Business and Professional | | Clearly Unacceptable | Clearly Unacceptable | Clearly Unacceptable |
| Commercial — Retail, Movie Theaters, Restaurants | | Clearly Unacceptable | Clearly Unacceptable | Clearly Unacceptable |
| Commercial — Wholesale, Some Retail, Ind., Mfg., Util. | | Clearly Unacceptable | Clearly Unacceptable | Clearly Unacceptable |
| Manufacturing, Communication (Noise Sensitive) | Clearly Unacceptable | Clearly Unacceptable | Clearly Unacceptable | Clearly Unacceptable |
| Livestock Farming, Animal Breeding | | Clearly Unacceptable | Clearly Unacceptable | Clearly Unacceptable |
| Agriculture (except Livestock), Mining, Fishing | | Clearly Unacceptable | Clearly Unacceptable | Clearly Unacceptable |
| Public Right-of-Way | | Clearly Unacceptable | Clearly Unacceptable | Clearly Unacceptable |
| Extensive Natural Recreation Areas | | Clearly Unacceptable | Clearly Unacceptable | Clearly Unacceptable |

*Ldn = NEF Value + 35

65 75 85
Ldn VALUES

| | | | |
|--|---------------------|--|-----------------------|
| | Clearly Acceptable | | Normally Unacceptable |
| | Normally Acceptable | | Clearly Unacceptable |

The ideal solution to a potential problem is to reduce the noise being produced by the source. The best solution available to HUD, or the community, however, is to make sure that noise sensitive uses are located where they will not be exposed to high noise levels. The next best approach to mitigating noise impact is to attempt to reduce the amount of noise that reaches the receiver. This can be accomplished through the use of barriers such as walls or earthen berms, or combinations of both, along the noise path. If the use of barriers is not possible then the only alternative available is to provide noise reduction measures in any structures associated with the activity so that at least the interior spaces are not exposed to high noise levels. This approach is considered the least desirable because most of the land uses we are concerned about, such as residential, do have outdoor areas and activities associated with them which would remain exposed to high noise levels.

A Note on Descriptors

A key factor in the growth of our ability to evaluate and reduce noise impacts has been the development of better tools to measure and describe the noise levels generated by various sources. The development of better tools (called noise descriptors or metrics) has been particularly important for dealing with community noise problems. Many of the older descriptor systems could only be used for one or two sources such as cars and railroads, but not airplanes. Since the community noise problem very often includes noise from all these sources the lack of an adequate descriptor made it difficult to do an adequate evaluation.

The most advanced descriptor currently in general use is the day night average sound level system, abbreviated as DNL and symbolized mathematically as L_{dn} . The day night average sound level is the 24 hour average sound level, expressed in decibels, obtained after the addition of a 10 decibel penalty for sound levels which occur at night between 10 PM and 7 AM. This nighttime penalty is based on the fact that many studies have shown that people are much more disturbed by noise at night than at any other time. This is not unusual in that background noise is often much less at night and also people tend to be doing very noise sensitive things at night, such as trying to sleep.

Another feature of the DNL system that is very important is that it can be used to describe noise from all sources. Thus, using the DNL system, we can describe the total noise exposure at a site, something many other descriptor systems couldn't do.

The DNL system has been adopted by the EPA, the Department of Defense (DOD) and HUD, and more recently by the FAA, specifically for describing environmental impacts for airport actions. We expect that very soon it will be in almost universal use in the U.S.

Issues

The main issues involved in any noise analysis can be summarized briefly.

- How much noise is a site exposed to
- What types of activities are being affected and how severely
- Is it reasonable to redesign the site to relocate noise sensitive activities
- And, if not, how much protection can be provided through various attenuation measures.

Your approach to these issues will be affected in many ways by the location of the project in question. Projects in suburban or rural areas can be approached differently because the available mitigation options are greater and often the noise exposure itself is not so severe. In urban situations, however, the noise exposure is often more severe but at the same time the options for mitigation or resiting are more limited. In the urban setting innovative design and the use of advanced attenuation measures becomes critical. Fortunately our experience has shown that good design and construction can relieve or substantially reduce major noise problems.

Legal Provisions

General Legislation and Background

The Federal legislation which addresses noise issues is somewhat different from other environmental legislation. The Clean Air Act, for example, required the Environmental Protection Agency to set up actual mandatory standards for air quality which were supposed to be met by all jurisdictions. EPA even has the authority to take punitive steps against cities which are not making "reasonable further progress" towards achieving these air quality goals. There is no similar legislation that covers noise. The approach has been to tackle the noise problem at the source by controlling the amount of noise that can be emitted by the individual airplane engine or the individual jackhammer. Agencies like HUD or the Farmers Home Administration have developed regulations which are related to the overall community noise level, but they only affect their own programs and are not binding on local communities. The Veterans Administration program only relates to aircraft noise and also only affects its own programs.

The major pieces of Federal legislation related to noise include:

The Noise Control Act of 1972 directed EPA to promote an environment for all Americans free from noise that jeopardizes their health and welfare. It also included a requirement for EPA to set a criterion for noise level adequate to protect health and welfare with an adequate margin of safety but without regard to cost or feasibility.

Quiet Communities Act of 1978 amended The Noise Control Act of 1972 to encourage noise control programs at the State and community level.

Federal Aid Highway Act of 1970 established the requirement that noise control be a part of the planning and design of all federally aided highways.

Aviation Safety and Noise Abatement Act of 1979 requires FAA to develop a single system for measuring noise at airports and under certain conditions to prepare and publish noise maps.

HUD Regulations

While the Department of Housing and Urban Development has no specific responsibility to try to reduce the noise problem at the source the way the Environmental Protection Agency and the Federal Aviation Administration do, it does have the responsibility to be aware of the noise problem and its impact on the housing environment. The most basic mandate which drives the Department's involvement with the noise issue is the Housing Act of 1949 (Public Law 81-171) which sets forth the national goal of "a decent home and suitable living environment for every American family." This goal was affirmed by the Housing and Urban Development Act of 1968 (Public Law 90-448). The Department was tasked by the Housing and Urban Development Act of 1965 (Public Law 89-117) "to determine feasible methods of reducing the economic loss and hardships suffered by homeowners as a result of the depreciation in the value of their properties following the construction of airports in the vicinity of their homes." The Noise Control Act of 1972, in addition to its specific tasking to EPA, tasked all Federal agencies to administer their programs in ways which reduce noise pollution. Finally, the Department is tasked by Federal Management Circular 75-2: *Compatible Land Uses at Federal Airfields* to make sure that its actions do not promote incompatible land uses around Federal airfields.

All of these legislative and regulatory mandates combine to create a serious requirement for the Department of Housing and Urban Development to be aware of the problem of noise and to take positive steps to protect residential and other sensitive land uses from high noise levels.

The Department of Housing and Urban Development first issued formal requirements related specifically to noise in 1971 (HUD Circular 1390.2). These requirements contained standards for exterior noise levels along with policies for approving HUD supported or assisted housing projects in high noise areas.

In general the requirements established three zones: an acceptable zone where all projects could be approved, a normally unacceptable zone where mitigation measures would be required and where each project would have to be individually evaluated for approval or denial, and an unacceptable zone in which projects would not, as a rule, be approved.

In 1979, the Department issued revised regulations (24 CFR Part 51B) which kept the same basic standards but adopted new descriptor systems which were considerably advanced over those in use under the old requirements.

HUD's regulations also require that recipients of Community Development Block Grants (CDBG) and Urban Development Action Grants (UDAG) take into consideration the noise criteria and standards in the environmental review process and consider ameliorative actions when noise sensitive land developments are proposed in noise exposed areas. If CDBG or UDAG activities are planned in a noisy area, and HUD assistance is contemplated later for housing and/or other noise sensitive activities, the HUD standards must be met for those activities.

Project Analysis

General

While most of the analysis for noise focuses on noise sources located around the project site, there are some characteristics of the project itself that you should know about. These characteristics will help you to determine what is called the noise assessment location (NAL) for site analysis. (The NAL is a representative point (or points) on the site where significant noise exposure is expected. All distances, etc. are measured from the NAL). This information will also be helpful later in evaluating the potential for mitigating or reducing the impact of noise. All of this data should be available from preliminary plans and specifications. If not, a quick phone call to the developer/sponsor should get you all the information you need.

Data Required

- Location of outdoor noise sensitive uses relative to the noise source.
- Location of buildings containing noise sensitive activities.
- Location of other buildings, particularly ones which might serve to shield sensitive buildings or areas from the noise source.
- Design and construction features of buildings, particularly features such as use of central air conditioning which could provide noise reduction benefits by permitting windows to be kept closed.

Analysis of Site and Environs

General

The primary focus of this impact analysis is on noise sources and the primary item to be determined is the noise level created by those sources. In many instances, particularly with airports, data on the noise levels generated by the source will have already been prepared by another agency such as the airport operator, the local or State highway/transportation department or other similar agency. (Figure 4 shows typical airport noise contours.) In those cases no site or environs analysis is necessary and one can proceed directly to impact analysis. For those instances where there are no current data already prepared, the Department of Housing and Urban Development has developed a handbook called the *Noise Assessment Guidelines* which contains a detailed desk top methodology for use by individuals to determine noise impacts (see Chapter 5). Included in the handbook is a complete listing of the data about the site and its environs that are necessary to conduct an analysis. We don't want to repeat all the detailed requirements here, but the following are some of the types of information you would have to collect if you were to do your own analysis. You might note that most of the information is related to the noise sources themselves.

For the purpose of analysis, the *Noise Assessment Guidelines* require that you consider all military/civilian airports within 15 miles of the project, all significant roads within 1000 feet and basically all railroads within 3000 feet.

Types of Data Required

- Number and type of vehicles
- Operational data:
 - speed
 - daytime/nighttime split
- Conditions where the vehicles are operated, i.e., freely flowing traffic versus stop and go, level versus hilly, welded railroad track versus bolted railroad track.

The *Noise Assessment Guidelines* contain guidance on sources for this data. Most of them are obtained from the "operator" of the transportation source. The *Guidelines* also contains model figures which can be used when actual data is unavailable. For example, if the actual number of vehicles traveling at night is not available then the *Guidelines* state that a figure of 15% should be used. Thus it is possible to make reasonably accurate noise level determinations even if some information is not available.

Determination of Impact

General

The specific procedures for determining the noise exposure levels for a site are clearly spelled out in the *Noise Assessment Guidelines*. The process is a fairly simple one in which the noise level from each source affecting the site is calculated and then combined to derive the overall exposure. If some kind of barrier exists or is proposed, the noise levels can be adjusted to reflect the mitigation provided by the barrier. The overall noise level is then compared to HUD's standards and the appropriate action, as spelled out in the regulations, is taken.

Figure 4
Noise Contours

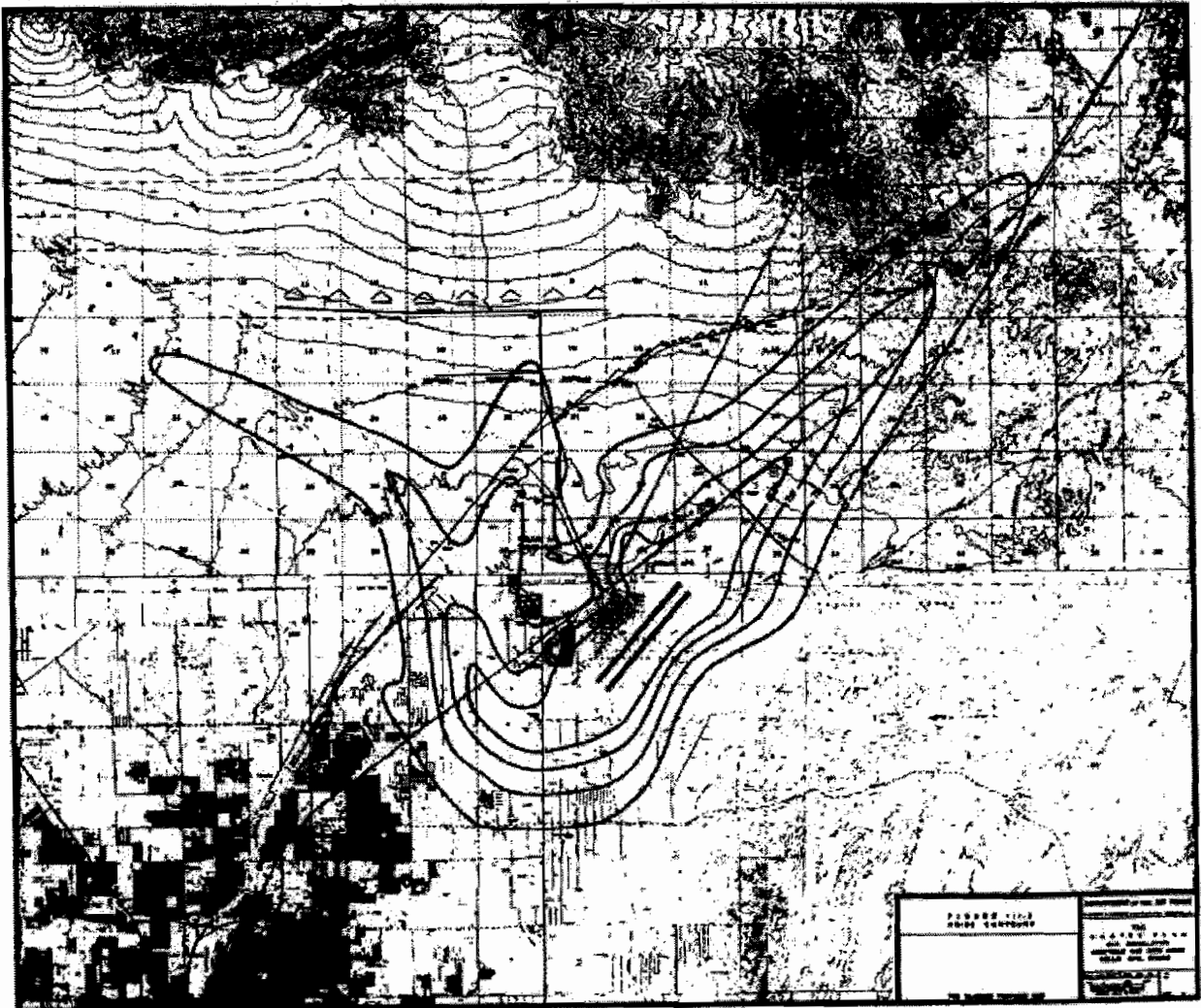

Evaluation of Impact

HUD Regulations set forth the following exterior noise standards for new housing construction assisted or supported by the Department:

65 L_{dn} or less - Acceptable

Exceeding 65 L_{dn} but not exceeding 75 L_{dn} - Normally Unacceptable - appropriate sound attenuation measures must be provided: 5 decibels attenuation above the attenuation provided by standard construction required in 65 L_{dn} to 70 L_{dn} zone; 10 decibels additional attenuation in 70 L_{dn} to 75 L_{dn} zone.

Exceeding 75 L_{dn} - Unacceptable

HUD's regulations do not contain standards for interior noise levels. Rather a goal of 45 decibels is set forth and the attenuation requirements are geared towards achieving that goal. It is assumed that with standard construction any building will provide sufficient attenuation so that if the exterior level is 65 L_{dn} or less, the interior level will be 45 L_{dn} or less.

Once you have determined the overall noise exposure for the site you compare it to the above standards. If the overall site exposure is 65 L_{dn} or less the project is acceptable. If the exposure is between 65 L_{dn} and 75 L_{dn} you should consider alternative locations or providing adequate attenuation with the first preference, as we've noted, being for the construction of some kind of barrier to prevent noise from reaching the site. If providing adequate attenuation is impossible or impractical then the project should be considered unacceptable.

Suggested Mitigation

General Considerations

As discussed briefly earlier, there are three basic approaches for mitigating the high noise exposures. The first and best is to relocate noise sensitive uses out of the high noise area. The second is to prevent noise from reaching the noise sensitive user through some sort of barrier. And the third, and least desirable approach, is to provide attenuation for at least the interiors of any buildings located in the high noise areas.

Specific Considerations

Relocating Noise Sensitive Uses

By far the most desirable mitigation approach is to relocate noise sensitive uses out of the high noise area although. If the site is large enough it may be possible to locate non-noise sensitive uses between the source and the sensitive use, for example a parking lot might be located between a road and a park (see Figure 5). The workcharts in the *Noise Assessment Guidelines* can be used in reverse to tell you exactly how far away from the noise source you need to be.

When sites are small, very dense or when the source affects the entire site it is very difficult to mitigate by changing the site plan. Then the next option must be considered: erecting some type of barrier between the source and the receiver.

Barriers

Barriers are most effective for at or below ground level sources. They have no effect on noise from aircraft overflights and are limited in practical application with elevated sources such as elevated trains. The key to the effectiveness of a barrier is whether or not it breaks the line of sight between the source and the receiver. If a barrier does not completely break the line of sight either because it is not high enough, or not long enough then its effectiveness is greatly reduced.

Barriers can be actual walls, earthen mounds (called berms) or even other buildings. The use of other non-noise sensitive buildings as barriers is a particularly good approach in that it need not add to the cost of the project and may not create the aesthetic problem a large wall might create (see Figure 6).

Figure 5
The Audible Landscape

In cluster development, open space can be placed near the highway to reduce noise impacts on residences

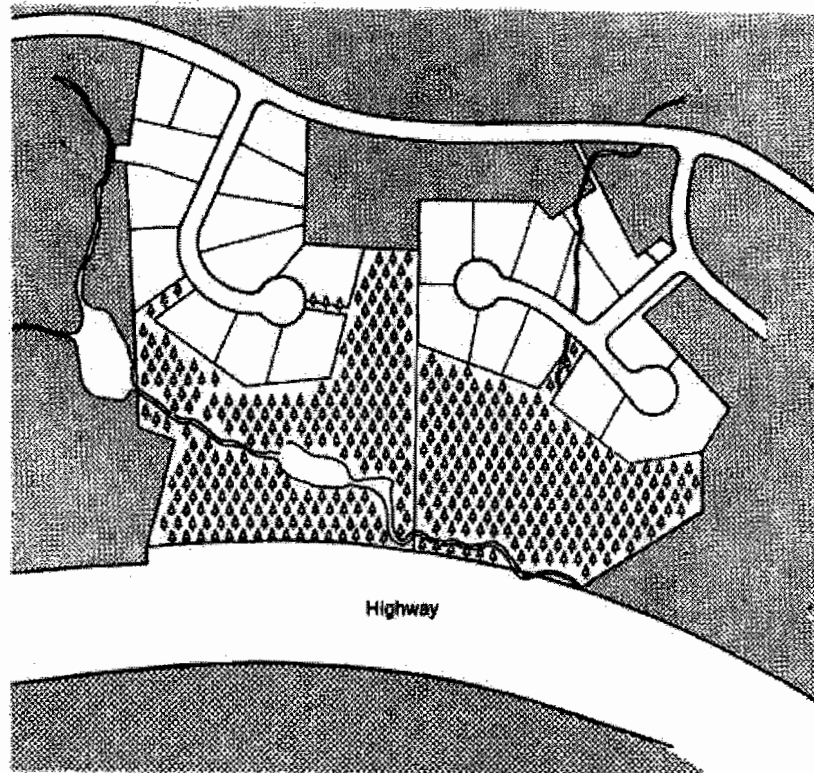

Figure 6
The Audible Landscape

Placement of noise compatible land uses near highway in Planned Unit Development

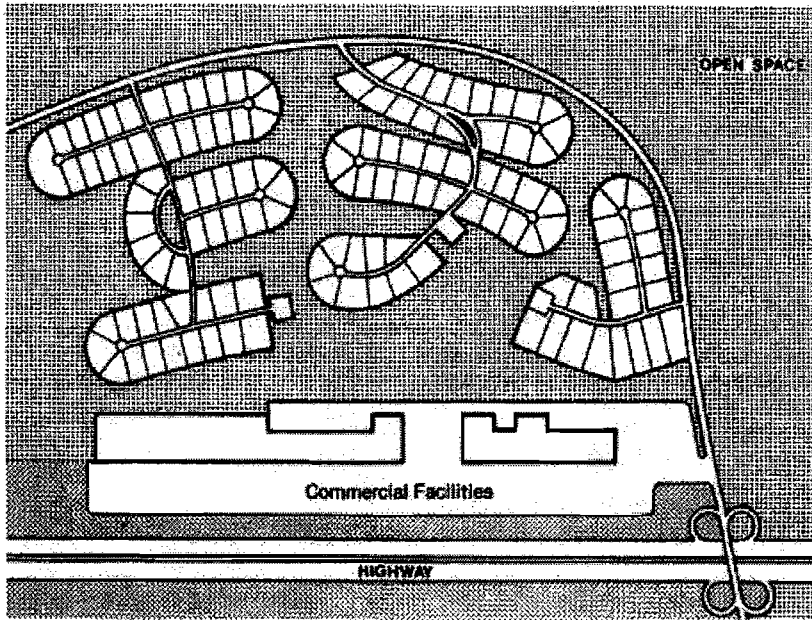
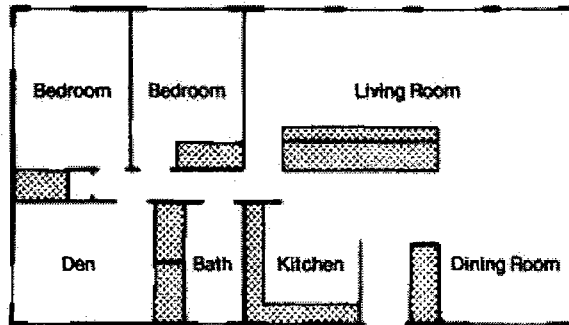

Figure 7
The Audible Landscape

Use of acoustical architectural design to reduce noise impacts on more noise sensitive living spaces



Highway

As pointed out earlier, the effectiveness of a barrier is determined in large part by its height and length. Some studies have shown that the effectiveness of a barrier can be reduced by as much as 50% if it isn't long enough. Again, the *Noise Assessment Guidelines* contain procedures for determining the effectiveness of barriers.

Incorporating Noise Attenuation Measures into the Building

If neither relocation or barriers is a reasonable noise attenuation option, the last resort is to incorporate noise attenuation measures into the buildings themselves. This is not considered the best solution because it leaves the outdoor areas, some of which may be for quiet recreation, exposed to high noise levels. But if development must take place and barriers are impossible, then the noise attenuation measures should be employed in building design and construction.

Without going into great technical detail, noise attenuation construction measures generally fall into four categories.

- (1) Reducing the total area of windows or other acoustically weaker building elements
- (2) Sealing off "leaks" around windows, doors, vents.
- (3) Improving the actual sound attenuating properties of small building elements such as windows, doors, etc.
- (4) Improving the actual sound attenuating properties of major building elements such as roof and wall construction.

In addition, noise attenuation in buildings can be provided by designing interior spaces so that "dead" spaces such as closets or corridors act as buffer zones (see Figure 7). And finally noise attenuation can be provided by reducing the need for open windows by providing air conditioning.

Many of the steps that would be taken to provide noise attenuation also help conserve energy. Good weatherstripping around windows and doors is one example. Another might be reducing window areas in walls if the noise source is to the north or west. Because many of these measures serve two purposes, they should not necessarily be considered a burdensome requirement but rather just good design and construction.

Information Resources

Publications

HUD Regulation 24-CFR Part 51 Subpart B - Noise Abatement and Control.

Noise Assessment Guidelines, HUD 1983, basic technical procedural resource.

Aircraft Noise Impact, HUD 1972, a bit dated but good overview of problem.

The Audible Landscape, DOT (FHWA) 1974, an excellent discussion of mitigation measures including land use planning and building design and construction.

Information on Levels of Environmental Noise Requisite to Protect Public Health and Welfare With an Adequate Margin of Safety, EPA, 1974. The "levels document" that explains basis for EPA standards.

Noise Barrier Design Handbook, Federal Highway Administration 1976. Good discussion of barriers, technical but readable.

Handbook of Noise Control, 2nd edition, 1979, McGraw Hill. A basic technical handbook covering all aspects of noise for those who wish to go into the subject further.

Experts

HUD environmental officers have been trained in the use of the *Noise Assessment Guidelines* and can help you work with them. Many architects are trained in acoustics and can help in development of noise attenuation strategies.

Quiz

Questions

1. Why is noise considered "unwanted sound"?
2. What is a community noise problem?
3. What are the three main contributors to a community noise problem?
4. What are the three components of a noise problem?
5. What are two key characteristics of the day-night average sound level descriptor system?
6. What are HUD's noise standards?
7. How do HUD's standards apply to CDBG recipients?
8. What are the three general mitigation measures available to HUD and the community and in what order of preference?
9. When are barriers effective and when are they not effective?
10. Describe how the *Noise Assessment Guidelines* can be used to determine appropriate mitigation measures.

Quiz

Answers

1. because it interferes with normal activities or causes physical or psychological damage
2. a community noise problem is where the combined effect of many individual sources creates an overall noise level that is unacceptable
3. highways, railroads and aircraft
4. the source, the path, the receiver
5. it is an average sound level and it can be used for all sources
6. 65 L_{dn} or below: Acceptable
7. CDBG recipients must take into consideration the standards in their planning and environmental review, if they expect to use HUD assistance later for housing or other noise sensitive activities the standards must be met for those activities.
8. 1st relocate noise sensitive uses
9. barriers are effective for at or below ground level sources. Are not effective for aircraft overflights or most elevated sources
10. can be used to determine separation distance required for relocation and the height and length of barriers required

Chapter 2

The Noise Regulation

Introduction

The basic foundation for and structure of the HUD noise program is set out in the noise regulation, 24 CFR 51B. The regulation establishes the actual standards, assigns implementation responsibilities, describes review and approval procedures, and identifies special situations which may warrant waivers of procedures or standards.

Therefore, the key to your understanding and implementation of the HUD noise program is a clear understanding of the regulation.

There is no way to escape the task of sitting down and simply reading the regulations, over and over until you thoroughly understand them. We have however done two things that will help you apply the regulations. First, for quick reference, we have prepared a list of the key sections in the regulation and second we have prepared an annotated copy of the regulation.

The list of key sections was prepared to help you find the specific section you need for a specific question or issue. While the regulation itself is not really long, an index is always useful. We caution you, however, against using the index to avoid learning the regulations. The list was prepared for your convenience in applying the regulation once you have come to understand it.

We prepared the annotated regulation because, try as we might, it was impossible to anticipate all the questions, implementation problems and special situations that might arise and to address them in the regulation. So, now that we have had a few years' experience with the regulation, we have gathered together the important questions, notes, second thoughts etc. and prepared this annotated regulation. We hope it will give you further insight into what the regulation means when it is applied in the field.

Key Sections in Noise Regulation

| Section | Subject |
|--------------|---|
| 51.101(a)(2) | Application of Policy to Block Grants |
| 51.101(a)(3) | Policy for New Construction |
| 51.101(a)(4) | Policy for Existing Construction |
| 51.101(a)(5) | Policy for Modernization and Rehabilitation |
| 51.101(a)(8) | The Exterior Noise Goal |
| 51.101(a)(9) | The Interior Noise Goal |
| 51.102(a) | Authority to Approve Projects |
| 51.103(a) | Identification of DNL as The Noise Descriptor to be Used |
| 51.103(b) | How to Measure Loud Impulsive Noises |
| 51.103(c) | The Noise Standards |
| 51.104(a) | Attenuation Requirements Discussed |
| 51.104(b)(1) | Special Approval and Environmental Review Requirements for the Normally Unacceptable Zone |
| 51.104(b)(2) | Special Approval and Environmental Review Requirements for the Unacceptable zone |
| 51.105(a) | Flexibility for Non-acoustic Benefits Provisions |
| 51.106(a) | How to Tell If Existing Data on Noise Are Acceptable |
| 51.106(a)(4) | Specific Review and Approval Procedures For Airport Noise Contours |
| 51.106(d) | When Noise Measurements May be Used Instead of Calculated Levels |
| 51.106(f) | When to Give Credit for Proposed Barriers |

Part 51—Environmental Criteria
and Standards

Subpart A—General Provisions

Sec.

§51.1 Purpose.

§51.2 Authority.

§51.3 Responsibilities.

§51.4 Program coverage.

§51.5 Coordination with environ-
mental clearance requirements.

§51.6 [Reserved]

Subpart B—Noise Abatement and
Control

§51.100 Purpose and authority.

§51.101 General policy.

§51.102 Responsibilities.

§51.103 Criteria and standards.

§51.104 Special requirements.

§51.105 Exceptions.

§51.106 Implementation.

Appendix to Subpart B

Authority: Sec. 7(d), Department of
HUD Act (42 U.S.C. 3535(d)).

Subpart B—Noise Abatement and
Control

§51.100 Purpose and authority.

(a) *Purpose.* The Department of
Housing and Urban Development
finds that noise is a major source of
environmental pollution which
represents a threat to the serenity
and quality of life in population
centers and that noise exposure may
be a cause of adverse physiological
and psychological effects as well as
economic losses.

It is the purpose of this Subpart
to:

(1) Call attention to the threat of
noise pollution;

(2) Encourage the control of noise
at its source in cooperation with
other Federal departments and
agencies;

(3) Encourage land use patterns
for housing and other noise sensitive
urban needs that will provide a
suitable separation between them
and major noise sources;

(4) Generally prohibit HUD support
for new construction of noise
sensitive uses on sites having
unacceptable noise exposure;

(5) Provide policy on the use of
structural and other noise
attenuation measures where needed;
and

This regulation replaces
HUD Circular 1390.2,
Noise Abatement and
Control, 1971, which is
now cancelled, along
with all instructions and
clarifying memoranda
pertaining to the
circular.

(6) Provide policy to guide
implementation of various HUD
programs.

(b) *Authority.* Specific authorities
for noise abatement and control are
contained in:

(1) The Noise Control Act of 1972
(Pub. L. 92-574) which directs Federal
agencies to administer their programs
in ways which reduce noise pollution.

(2) The Quiet Communities Act of
1978 (Pub. L. 95-609) which amended
Pub. L. 92-574.

(3) The General Services
Administration, Federal Management
Circular 75-2: *Compatible Land Uses
at Federal Airfields* prescribes the
Executive Branch's general policy
with respect to achieving compatible
land uses on either public or privately
owned property at or in the vicinity of
Federal airfields.

(4) Section 1113 of the Housing
and Urban Development Act of 1965
(Pub. L. 89-117) directs the Secretary
" . . . to determine feasible methods
of reducing the economic loss and
hardships suffered by homeowners as
a result of the depreciation in the
value of their properties following the
construction of airports in the vicinity
of their homes, including a study of
feasible methods of insulating such
homes from the noise of aircraft."

§51.101 General policy.

(a) It is HUD's general policy to
provide minimum national standards
applicable to HUD programs to
protect citizens against excessive
noise in their communities and places
of residence.

(1) *Comprehensive planning assist-
ance.* HUD requires that grantees
give adequate consideration to noise
exposures and sources of noise as an
integral part of the urban environment
in HUD assisted comprehensive plan-
ning, as follows:

(i) Particular emphasis shall be
placed on the importance of
compatible land use planning in
relation to airports, highways and
other sources of high noise.

(ii) Applicants shall take into
consideration HUD environmental
standards impacting the use of land
as required in 24 CFR Part 600.

(iii) Environmental studies,
including noise assessments, are
allowable costs.

(2) *Community Development Block
Grants.* Recipients of community
development block grants under the
Housing and Community
Development Act of 1974 (Pub. L.
93-383), as amended by the Housing
and Community Development Act of
1977 (Pub. L. 95-128), must take into

consideration the noise criteria and standards in the environmental review process and consider ameliorative actions when noise sensitive land development is proposed in noise exposed areas. Grant recipients shall address deviations from the standards in their environmental reviews as required in 24 CFR Part 58.

Where CDBG activities are planned in a noisy area, and HUD assistance is contemplated later for housing and/or other noise sensitive activities, the CDBG grantee risks denial of the HUD assistance unless the HUD standards are met. Environmental studies, including noise assessments, are allowable costs.

(3) *HUD support for new construction.* HUD assistance for the construction of new noise sensitive uses is prohibited generally for projects with Unacceptable noise exposures and is discouraged for projects with Normally Unacceptable noise exposure. (Standards of acceptability are contained in §51.103(c).) This policy applies to all HUD programs providing assistance, subsidy or insurance for housing, college housing, mobile home parks, nursing homes, hospitals, and all programs providing assistance or insurance for land development, new communities, redevelopment or any other provision of facilities and services which are directed to make land available for housing or noise sensitive development. The policy does not apply to research demonstration projects which do not result in new construction or reconstruction, flood insurance, interstate land sales registration, or any action or emergency assistance under disaster assistance programs which are provided to save lives, protect property, protect public health and safety, remove debris and wreckage, or assistance provided that has the effect of restoring facilities substantially as they existed prior to the disaster.

(4) *HUD support for existing construction.* Noise exposure by itself will not result in the denial of HUD support for the resale and purchase of otherwise acceptable existing buildings. However, environmental noise is a marketability factor which HUD will consider in determining the amount of insurance or other assistance that may be given.

The old definition of major or substantial rehabilitation and modernization as being any project where cost is 75% or more of replacement cost no longer applies. Now the criteria contained in individual program guidance applies.

(5) *HUD support of modernization and rehabilitation.* For modernization projects located in all noise exposed areas, HUD shall encourage noise attenuation features in alterations. For major or substantial rehabilitation projects in the Normally Unacceptable and Unacceptable noise zones, HUD actively shall seek to have project sponsors incorporate noise attenuation features, given the extent of the rehabilitation being undertaken and the level of exterior noise exposure. In Unacceptable noise zones, HUD shall strongly encourage conversion of noise-exposed sites to land uses compatible with the high noise levels.

(6) *Research, guidance and publications.* HUD shall maintain a continuing program designed to provide new knowledge of noise abatement and control to public and private bodies, to develop improved methods for anticipating noise encroachment, to develop noise abatement measures through land use and building construction practices, and to foster better understanding of the consequences of noise. It shall be HUD's policy to issue guidance documents periodically to assist HUD personnel in assigning an acceptability category to projects in accordance with noise exposure standards, in evaluating noise attenuation measures, and in advising local agencies about noise abatement strategies. The guidance documents shall be updated periodically in accordance with advances in the state-of-the-art.

(7) *Construction equipment, building equipment and appliances.* HUD shall encourage the use of quieter construction equipment and methods in population centers, the use of quieter equipment and appliances in buildings, and the use of appropriate noise abatement techniques in the design of residential structures with potential noise problems.

Existing construction means units which are either more than 1 year old or for which this is the second or subsequent purchaser.

(8) *Exterior noise goals.* It is a HUD goal that exterior noise levels do not exceed a day-night average sound level of 55 decibels. This level is recommended by the Environmental Protection Agency as a goal for outdoors in residential areas. The levels recommended by EPA are not standards and do not take into account cost or feasibility. For the purposes of this regulation and to meet other program objectives, sites with a day-night average sound level of 65 and below are acceptable and are allowable (see Standards in §51.103(c)).

(9) *Interior noise goals.* It is a HUD goal that the interior auditory environment shall not exceed a day-night average sound level of 45 decibels. Attenuation measures to meet these interior goals shall be employed where feasible. Emphasis shall be given to noise sensitive interior spaces such as bedrooms. Minimum attenuation requirements are prescribed in §51.104(a).

(10) *Acoustical privacy in multifamily buildings.* HUD shall require the use of building design and acoustical treatment to afford acoustical privacy in multifamily buildings pursuant to requirements of the Minimum Property Standards.

§51.102 Responsibilities.

(a) *Authority to approve projects.* (1) Decisions on proposed projects with acceptable noise exposures shall be delegated to the program personnel within field offices, including projects where increased noise levels are considered acceptable because of non-acoustic benefits under §51.105(a). Field office program personnel may also approve projects in normally unacceptable noise exposed areas where adequate sound attenuation is provided and where the project does not require an Environmental Impact Statement under §51.104(b).

(2) Other approvals in normally unacceptable noise exposed areas require the concurrence of the Regional Administrator.

(3) Requests for approvals of projects or portions of projects with unacceptable noise exposures shall be referred through the Regional Office to the Assistant Secretary for Community Planning and Development for approval pursuant to §51.104(b).

The Noise Control Act of 1972 required EPA to "publish information on the levels of environmental noise... which... are requisite to protect the public health and welfare with an adequate margin of safety." EPA has interpreted this to mean that the levels should not reflect technical feasibility or economic costs. "Health and welfare" is defined as being "complete physical, mental and social well-being and not merely the absence of disease and infirmity."

(4) In cases where the Regional Administrator determines that an important precedent or issue is involved, such cases shall be referred with recommendations to the Assistant Secretary for Community Planning and Development.

(b) *Surveillance of noise problem areas.* Appropriate field staff shall maintain surveillance of potential noise problem areas and advise local officials, developers, and planning groups of the unacceptability of sites because of noise exposure at the earliest possible time in the decision process. Every attempt shall be made to insure that applicants' site choices are consistent with the policy and standards contained herein.

(c) *Notice to applicants.* At the earliest possible stage, HUD program administrators shall:

(1) Determine the suitability of the acoustical environment of proposed projects;

(2) Notify applicants of any adverse or questionable situations; and

(3) Assure that prospective applicants are apprised of the standards contained herein so that future site choices will be consistent with these standards.

(d) *Technical assistance.* Technical assistance in the measurement, estimation, interpretation, or prediction of noise exposure is available from the Office of Community Planning and Development and the Office of Policy Development and Research. Field office questions shall be forwarded through the Regional Office to the Assistant Secretary for Community Planning and Development or his designee.

(e) *Interdepartmental coordination.* Regional Administrators shall foster appropriate coordination between field offices and other departments and agencies, particularly the Environmental Protection Agency, the Department of Transportation, Department of Defense representatives, and the Veterans Administration. HUD staff shall utilize the acceptability standards in commenting on the prospective impacts of transportation facilities and other noise generators in the Environmental Impact Statement review process.

§51.103 Criteria and standards.

These standards apply to all programs as indicated in §61.101.

(a) *Measure of external noise environments.* The magnitude of the external noise environment at a site is determined by the value of the day-night average sound level produced as the result of the accumulation of noise from all sources contributing to the external noise environment at the site. Day-night average sound level, abbreviated as DNL and symbolized as L_{dn} , is the 24-hour average sound level, in decibels, obtained after addition of 10 decibels to sound levels in the night from 10 p.m. to 7 a.m. Mathematical expressions for average sound level and day-night average sound level are stated in the Appendix.

(b) *Loud impulsive sounds.* On an interim basis, when loud impulsive sounds, such as explosions or sonic booms, are experienced at a site, the day-night average sound level produced by the loud impulsive sounds alone shall have 8 decibels added to it in assessing the acceptability of the site (see Appendix). Alternatively, the C-weighted day-night average sound level (L_{Cdn}) may be used without the 8 decibel addition, as indicated in Section 51.106(a)(3).

Methods for assessing the contribution of loud impulsive sounds to day-night average sound level at a site and mathematical expressions for determining whether a sound is classed as "loud impulsive" are provided in the Appendix.

(c) *Exterior standards.* The degree of acceptability of the noise environment at a site is determined by the sound levels external to buildings or other facilities containing noise sensitive uses. The standards shall usually apply at a location 2 meters (6.5 feet) from the building housing noise sensitive activities in the direction of the predominant noise source. Where the building location is undetermined, the standards shall apply 2 meters (6.5 feet) from the building setback line nearest to the predominant noise source. The standards shall also apply at other locations where it is determined that quiet outdoor space is required in an area ancillary to the principal use on the site.

The noise environment inside a building is considered acceptable if (a) the noise environment external to the building complies with these standards, and (b) the building is constructed in a manner common to the area or, if of uncommon construction, has at least the equivalent noise attenuation characteristics.

This is because the reverberation effect of sound waves hitting the wall will increase the noise levels at the site. You won't pick this up unless you back off from the wall to measure.

Site Acceptability Standards

| | Day-night average sound level (in decibels) | Special approvals and requirements |
|-----------------------------|---|--|
| Acceptable _____ | Not exceeding 65 dB(1) _____ | None |
| Normally Unacceptable _____ | Above 65 dB but not exceeding 75 dB _____ | Special Approvals (2) Environmental Review (3) Attenuation (4) |
| Unacceptable _____ | Above 75 dB _____ | Special Approvals (2) Environmental Review (3) Attenuation (5) |

Notes.—(1) Acceptable threshold may be shifted to 70 dB in special circumstances pursuant to Section 51.105(a)

(2) See Section 51.104(b) for requirements.

(3) See Section 51.104(b) for requirements.

(4) 5 dB additional attenuation required for sites above 65 dB but not exceeding 70 dB and 10 dB additional attenuation required for sites above 70 dB but not exceeding 75 dB. (See Section 51.104(a).)

(5) Attenuation measures to be submitted to the Assistant Secretary for CPD for approval on a case-by-case basis.

§51.104 Special requirements.

(a) *Noise attenuation.* Noise attenuation measures are those required in addition to attenuation provided by buildings as commonly constructed in the area, and requiring open windows for ventilation. Measures that reduce external noise at a site shall be used wherever practicable in preference to the incorporation of additional noise attenuation in buildings. Building designs and construction techniques that provide more noise attenuation than typical construction may be employed also to meet the noise attenuation requirements.

(1) *Normally Unacceptable noise zone.* Approvals in this zone require a minimum of 5 decibels additional sound attenuation for buildings having noise-sensitive uses if the day-night average sound level is greater than 65 decibels but does not exceed 70 decibels, or a minimum of 10 decibels of additional sound attenuation if the day-night average sound level is greater than 70 decibels but does not exceed 75 decibels.

(2) *Unacceptable noise zone.* Noise attenuation measures require the approval of the Assistant Secretary for Community Planning and Development (See §51.104(b)(2).)

(b) *Special Approvals and Environmental Review Requirements.* Environmental clearances shall be conducted pursuant to the requirements of HUD's Departmental Policies, Responsibilities and Procedures for Protection and Enhancement of Environmental Quality (38 FR 19182 as amended) or other environmental regulations which may be issued by the Department. The Special Clearance and Environmental Impact Statement (EIS) threshold requirements are hereby modified for all projects proposed in the Normally Unacceptable and Unacceptable noise exposure zones as follows:

(1) *Normally Unacceptable noise zone.* (i) All projects located in the Normally Unacceptable Noise Zone require a Special Environmental Clearance except an EIS is required for a proposed project located in a largely undeveloped area, or where the HUD action is likely to encourage the establishment of incompatible land use in this noise zone.

Berms and barriers are our first choice because they provide protection for yards, playgrounds, etc. Since outdoor activity is often very important to residents we want to protect the outdoor areas as much as possible.

By definition a barrier must be separate from the building or area it is providing attenuation for. After all barriers are preferred because they improve exterior as well as interior levels. Non-noise sensitive buildings can, however, be used as barriers for noise sensitive buildings or exterior areas.

Assumption is that standard construction provides an average of 20 L_{dn} attenuation. At 65 L_{dn} or below this amount of attenuation would be sufficient to meet interior level of 45 L_{dn}. Additional requirements are designed to meet this goal even when exterior noise levels are higher.

Substitute Environmental Assessment (with ECO concurrence) wherever you see Special Clearance.

(ii) When an EIS is required, the concurrence of the Regional Administrator is also required before a project can be approved. For the purposes of this paragraph, an area will be considered as largely undeveloped unless the area within a 2-mile radius of the project boundary is more than 50 percent developed for urban uses and infrastructure (particularly water and sewers) is available and has capacity to serve the project.

(iii) All other projects in the Normally Unacceptable zone require a Special Environmental Clearance, except where an EIS is required for other reasons pursuant to HUD environmental policies.

(2) **Unacceptable noise zone.** An EIS is required prior to the approval of projects with unacceptable noise exposure. Projects in or partially in an Unacceptable Noise Zone shall be submitted through the Regional Administrator to the Assistant Secretary for Community Planning and Development for approval. The Assistant Secretary may waive the EIS requirement in cases where noise is the only environmental issue and no outdoor sensitive activity will take place on the site. In such cases, a Special Environmental Clearance is required.

§51.105 Exceptions.

(a) **Flexibility for non-acoustic benefits.** Where it is determined that program objectives cannot be achieved on sites meeting the acceptability standard of 65 decibels, the Acceptable Zone may be shifted to L_{dn} 70 on a case-by-case basis if all the following conditions are satisfied:

(1) The project does not require an Environmental Impact Statement under provisions of section 104(b)(1) and noise is the only environmental issue.

(2) The project has received a Special Environmental Clearance and has received the concurrence of the Environmental Clearance Officer.

(3) The project meets other program goals to provide housing in proximity to employment, public facilities and transportation.

(4) The project is in conformance with local goals and maintains the character of the neighborhood.

(5) The project sponsor has set forth reasons, acceptable to HUD, as to why the noise attenuation measures that would normally be required for new construction in the L_{dn} 65 to L_{dn} 70 zone cannot be met.

When the area in question is in a small community outside an SMSA and the application of the 2 mile radius rule would be unreasonable, an area can be considered largely developed if it is contiguous to existing development and infrastructure is available and has capacity to serve the project. The Assistant Secretary will review them on a case-by-case basis. In all other cases the 2 mile radius/50% rule still applies.

Caution—every effort should be made to get official contours—particularly for military installations and large air carrier airports rather than trying to use the *Noise Assessment Guidelines*.

What this really means is that the 5db attenuation requirement for the 65-70 L_{dn} zone is waived. Primarily intended for urban areas where alternative sites are not available. Note that *all* conditions must be met.

These requirements are very important. Be careful with design hour values.

(6) Other sites which are not exposed to noise above L_{dn} 65 and which meet program objectives are generally not available.

The above factors shall be documented and made part of the project file.

§51.106 Implementation.

(a) **Use of available data.** HUD field staff shall make maximum use of noise data prepared by others when such data are determined to be current and adequately projected into the future and are in terms of the following:

(1) **Sites in the vicinity of airports.** The noise environment around airports is described sometimes in terms of Noise Exposure Forecasts, abbreviated as NEF or, in the State of California, as Community Noise Equivalent Level, abbreviated as CNEL. The noise environment for sites in the vicinity of airports for which day-night average sound level data are not available may be evaluated from NEF or CNEL analyses using the following conversions to DNL:

$$DNL = NEF + 35$$

$$DNL = CNEL$$

(2) **Sites in the vicinity of highways.** Highway projects receiving Federal aid are subject to noise analyses under the procedures of the Federal Highway Administration.

Where such analyses are available they may be used to assess sites subject to the requirements of this standard. The Federal Highway Administration employs two alternate sound level descriptors: (a) The A-weighted sound level not exceeded more than 10 percent of the time for the highway design hour traffic flow, symbolized as L_{10} ; or (b) the equivalent sound level for the design hour, symbolized as L_{eq} . The day-night average sound level may be estimated from the design hour L_{10} or L_{eq} values by the following relationships, provided heavy trucks do not exceed 10 percent of the total traffic flow in vehicles per 24 hours and the traffic flow between 10 p.m. and 7 a.m. does not exceed 15 percent of the average daily traffic flow in vehicles per 24 hours:

$$DNL = L_{10} \text{ (design hour)} - 3 \text{ decibels}$$

$$DNL = L_{eq} \text{ (design hour) decibels}$$

Where the auto/truck mix and time of day relationships as stated in this Section do not exist, the HUD Noise Assessment Guidelines or other noise analysis shall be used.

(3) *Sites in the vicinity of installations producing loud impulsive sounds.* Certain Department of Defense installations produce loud impulsive sounds from artillery firing and bombing practice ranges. Noise analyses for these facilities sometimes encompass sites that may be subject to the requirements of this standard. Where such analyses are available they may be used on an interim basis to establish the acceptability of sites under this standard.

The Department of Defense uses day-night average sound level based on C-weighted sound level, symbolized L_{Cdn} , for the analysis of loud impulsive sounds. Where such analyses are provided, the 8 decibel addition specified in 51.103(b), is not required, and the same numerical values of day-night average sound level used on an interim basis to determine site suitability for non-impulsive sounds apply to the L_{Cdn} .

(4) *Use of areawide acoustical data.* HUD encourages the preparation and use of areawide acoustical information, such as noise contours for airports. Where such new or revised contours become available for airports (civil or military) and military installations they shall first be referred to the Regional Office (Environmental Clearance Officer) for review, evaluation and decision on appropriateness for use by HUD. The Regional Office shall submit revised contours to the Assistant Secretary of Community Planning and Development for review, evaluation and decision whenever the area affected is changed by 20 percent or more, or whenever it is determined that the new contours will have a significant effect on HUD programs, or whenever the contours are not provided in a methodology acceptable under §51.106(a)(1) or in other cases where the Regional Office determines that Headquarters review is warranted. For other areawide acoustical data, review is required only where existing areawide data are being utilized and where such data have been changed to reflect changes in the measurement methodology or underlying noise source assumptions.

Contours for future noise levels based on new construction, mission changes etc. which become available as part of the Environmental Impact Statement process shall not be used until the NEPA process is complete and a decision on the proposed action is made.

When new or revised contours are approved, make sure all interested people in local area are informed that HUD will be using different contours. Make a special effort to inform the most active developers in area or developers who have worked with HUD before.

This is also required for noise studies for developers by consultants, whether to provide original data, or to contest existing data or a HUD analysis. It is particularly important to make sure the same traffic, vehicle or operational data were used for each study, when one study is being contested.

Requests for determination on usage of new or revised areawide data shall include the following:

(i) Maps showing old, if applicable, and new noise contours, along with brief description of data source and methodology.

(ii) Impact on existing and prospective urbanized areas and on development activity.

(iii) Impact on HUD-assisted projects currently in processing.

(iv) Impact on future HUD program activity. Where a field office has determined that immediate approval of new areawide data is necessary and warranted in limited geographic areas, the request for approval should state the circumstances warranting such approval. Actions on proposed projects shall not be undertaken while new areawide noise data are being considered for HUD use except where the proposed location is affected in the same manner under both the old and new noise data.

(b) *Site assessments.* Compliance with the standards contained in §51.103(c) shall, where necessary, be determined using noise assessment guidelines, handbooks, technical documents and procedures issued by the Department.

(c) *Variations in site noise levels.* In many instances the noise environment will vary across a site, with portions of the site being in an Acceptable noise environment and other portions in a Normally Unacceptable noise environment. The standards in §51.103(c) shall apply to the portions of a building or buildings used for residential purposes and for ancillary noise sensitive open spaces.

(d) *Noise measurements.* Where noise assessments result in a finding that the site is borderline or questionable, or is controversial, noise measurements may be performed. Where it is determined that noise measurements are required, such measurements will be conducted in accordance with methods and measurement criteria established by the Department. Locations for noise measurements will depend on the location of noise sensitive uses that are nearest to the predominant noise source (see §51.103(c)).

(e) *Projections of noise exposure.* In addition to assessing existing exposure, future conditions should be projected. To the extent possible, noise exposure shall be projected to be representative of conditions that are expected to exist at a time at least 10 years beyond the date of the project or action under review.

(f) *Reduction of site noise by use of berms and/or barriers.* If it is determined by adequate analysis that a berm and/or barrier will reduce noise at a housing site, and if the barrier is existing or there are assurances that it will be in place prior to occupancy, the environmental noise analysis for the site may reflect the benefits afforded by the berm and/or barrier.

In the environmental review process under §51.104(b), the location height and design of the berm and/or barrier shall be evaluated to determine its effectiveness, and impact on design and aesthetic quality, circulation and other environmental factors.

Appendix to Subpart B—definition of acoustical quantities

1. *Sound Level.* The quantity in decibels measured with an instrument satisfying requirements of American National Standard Specification for Type 1 Sound Level Meters S1.4-1971. Fast time-averaging and A-frequency weighting are to be used, unless others are specified. The sound level meter with the A-weighting is progressively less sensitive to sounds of frequency below 1,000 hertz (cycles per second), somewhat as is the ear. With fast time averaging the sound level meter responds particularly to recent sounds almost as quickly as does the ear in judging the loudness of a sound.

(2) *Average Sound Level.* Average sound level, in decibels, is the level of the mean-square A-weighted sound pressure during the stated time period, with reference to the square of the standard reference sound pressure of 20 micropascals.

When projections for airports are based on new construction or similar actions the likelihood that such major action will actually take place should be carefully evaluated. This is particularly important if local funding is required. Check to see if initial actions such as land purchases, bonds etc. been taken. If projections are just based on expanded traffic levels make sure they are reasonable for the area. Projections for smaller communities are often overly optimistic.

This provision should be used with caution. Very clear and strong assurances that berms or barriers will be constructed should be obtained in writing before approval.

Again also note that by definition a barrier must be physically separate from the building or area it is providing attenuation for.

The *Noise Assessment Guidelines* contain procedures for evaluating barrier effectiveness.

$$L_{\text{eq}} = 10 \log_{10} \left[\frac{1}{86400} \left(\int_{0000}^{0700} 10 [L_A(t) + 10] 10 dt + \int_{0700}^{2200} 10 L_A(t) 10 dt + \int_{2200}^{2400} 10 [L_A(t) + 10] 10 dt \right) \right]$$

Time t is in seconds, so the limits shown in hours and minutes are actually interpreted in seconds. $L_A(t)$ is the time varying value of A-weighted sound level, the quantity in decibels measured by an instrument satisfying requirements of American National Standard Specification for Type 1 Sound Level Meters S1.4-1971.

3. **Loud Impulsive Sounds.** When loud impulsive sounds such as sonic booms or explosions are anticipated contributors to the noise environment at a site, the contribution to day-night average sound level produced by the loud impulsive sounds shall have 8 decibels added to it in assessing the acceptability of a site.

A loud impulsive sound is defined for the purpose of this regulation as one for which:

(i) The sound is definable as a discrete event wherein the sound level increases to a maximum and then decreases in a total time interval of approximately one second or less to the ambient background level that exists without the sound; and

(ii) The maximum sound level (obtained with slow averaging time and A-weighting of a Type 1 sound level meter whose characteristics comply with ANSI S1.4-1971) exceeds the sound level prior to the onset of the event by at least 6 decibels; and

(iii) The maximum sound level obtained with fast averaging time of a sound level meter exceeds the maximum value obtained with slow averaging time by at least 4 decibels.

Issued at Washington, D.C., on July 5, 1979.

Patricia Roberts Harris,
Secretary of Housing and Urban Development.

[FR Doc. 79-21481 Filed 7-11-79; 8:45 am]

BILLING CODE 4210-01-11

Quiz on the Noise Regulations

Questions

1. What is the HUD policy on support for existing construction in high noise areas?
2. What is the definition of "major or substantial rehabilitation"?
3. What is HUD's interior noise goal?
4. What project approval authority does the Field Office have?
5. Who approves projects in the Unacceptable Zone?
6. What noise descriptor is used to express noise levels in the regulation?

7. How are loud impulsive sounds to be evaluated?

8. At what point on a building's exterior are sound levels to be determined?

9. What is the basic assumption behind the attenuation levels required?

10. What type of attenuation measures are preferred?

11. When should building attenuation measures be considered?

12. When are EIS's required?

13. When is an area considered "largely undeveloped"?

14. What is "Flexibility for Non-Acoustic Benefits"?

15. Six conditions are listed for waiving the attenuation requirement under the Flexibility for Non-Acoustic Benefits provision, how many must be met for the waiver to be granted?

16. Who has the authority to grant the attenuation requirements waiver under the "flexibility" provision?

17. What noise descriptors other than DNL are acceptable for aircraft noise contours?

18. Who normally approves areawide noise data such as airport noise contours?

19. If a site is partially in the Unacceptable Zone and partially in the Normally Unacceptable Zone, which review and approval procedures apply?

20. When should noise measurements be used in lieu of areawide data or *Noise Assessment Guidelines* calculations?

Quiz on the Noise Regulations

Answers

1. A provision in the regulations which allows the attenuation requirements for the 65-70 L_{dn} zone to be waived (Section 51.105(a) and marginal note)
2. All six conditions must be met. (Section 51.105(a))
3. The field office. (Section 51.106(a))
4. NEF and CNEF. (Section 51.106(a)(1))
5. The Regional Office. (Section 51.106(a)(4))
6. The review and approval procedures for projects in the Unacceptable Zone apply. (Section 51.104(b)(2))
7. Only when the noise assessment indicates that the site is on the borderline between Acceptable and Unacceptable, or when the site is controversial. (Section 51.106(d))

1. Noise exposure can not, by itself, be the basis for denying support for resale and purchase of existing buildings. (Section 51.101(a)(4))
2. "Major or substantial rehabilitation" is defined in individual program guidance. There is no single definition. (51.101(a)(5) marginal note)
3. 45 L_{dn} (Section 51.101(a)(9))
4. Projects in Acceptable Zone; also projects in Normally Unacceptable Zone provided that
 - adequate sound attenuation is provided
 - no EIS is required (Section 51.102(a)(1))
5. The Assistant Secretary for Community Planning and Development. (Section 51.102(a)(3) and 51.104(b))
6. The day night average sound level system (DNL) (Section 51.103(a))
7. Two ways:
 - If plain DNL levels have been calculated or measured, add a 8 decibel penalty.
 - Alternatively, the C weighted day night average sound level system (LCN) can be used as is. (Section 51.103(b))
8. Two meters (6.5 feet) away from the building exterior, moving towards the predominant noise source. (Section 51.103(c))
9. That current construction practices provide about 20 db attenuation. Thus in a 65 L_{dn} or lower area the interior goal of 45 L_{dn} would be met with standard construction. The additional attenuation required by the increment over that provided by standard construction necessary to achieve the interior goal of 45 L_{dn} (Section 51.104(a) marginal note)
10. Measures which reduce exterior noise levels. (51.104(a))
11. Only after it has been determined that berms and barriers or site redesign are not practical (Section 51.104(a))
12. When the project is located in the Unacceptable Zone or the project is located in a largely undeveloped area and the project is in the Normally Unacceptable Zone. (Section 51.104(b))
13. When the area within a 2 mile radius of the project is less than 50% developed for urban uses and intrasuburban is not in place and available to serve the project. (Section 51.104(b)(1)(iii))

Chapter 3

Major Policy and Implementation Questions Related to the Noise Regulation

As regulations are applied in the field, it is inevitable that questions will arise. It is, after all, very difficult to anticipate every situation when preparing a regulation. Sometimes the questions relate to specific and unique situations of limited interest to anyone but the office involved. Other questions, however, raise issues of more general concern. In this section we have brought together the most important and most relevant questions that have arisen since the noise regulation went into effect in August of 1979. We have used a question and answer format for your convenience.

The following are the topics included:

1. Noise projections for civil airports
2. Definition of infill for small towns
3. Areawide EIS waivers
4. Requirements for modernization and rehabilitation projects
5. Use of berms and barriers as attenuation measures
6. New and revised airport noise contours

Questions and Answers

1. How valid and useful are civil airport noise projections that show significant reductions in the amount of land exposed to high noise levels? Should we be suspicious?

Contours that show significant reductions in the area exposed to high noise levels may seem questionable, but, according to the Environmental Protection Agency, they may be quite accurate. The EPA does expect to see some significant reductions in the number of people exposed to high levels of aircraft noise over the next 15 years. In their report *Aviation Noise: The Next Twenty years*, EPA stated that they expected to see the number of people exposed to levels of 65 Ldn or greater to drop from a 1975 figure of 5,550,000 to about 2,650,000 in the year 2000. Much of this reduction would occur during the period 1980-1985 with more modest decreases thereafter. The reductions are expected to result from the Federal Aviation Administration's current noise certification requirements, even with up to 100% increases in aircraft operations. (Current certification requirements are for all new aircraft to achieve stage three noise levels and all older aircraft to achieve stage two levels by 1985. Progress has been good in meeting these requirements.)

In general then, you should not be surprised to see significant reductions in contour size if the following conditions are met:

- the decrease in size is no more than 50%;
- the increase in operations is no more than 100%; and
- FAR stage 3 aircraft, such as the B757 and B767, are included in the fleet mix, but not to the total exclusion of all other aircraft. Assuming that the contours are otherwise technically correct, significantly smaller contours should be acceptable.

2. Many small towns aren't big enough for a project to meet the definition of infill contained in section 51.104 (b)(1)(ii). However, a project located in the heart of town can hardly be considered to be in a largely undeveloped area. Must an EIS be prepared?

Not necessarily. If the jurisdiction in which the project is located is not part of a standard metropolitan area, a project may be considered infill if it is within or contiguous to the already developed area and infrastructure (particularly water and sewer) is available and has the capacity to serve the project. It must also be clear that the project will not encourage the establishment of other incompatible land uses in the normally unacceptable noise zone.

If you believe a project meets these criteria, submit documentation to the Office of Environment and Energy for their review and determination.

3. What can we do to reduce the procedural burden when, for a variety of reasons, the Department expects to be considering a number of projects in an unacceptable noise zone? Most of the projects would probably qualify for an EIS waiver, but how can we avoid filing repetitive, individual requests?

While the number of cases where the Department would be seriously considering a number of projects exposed to unacceptable noise levels in the same jurisdiction is likely to be limited, there is an alternative to individual processing in those situations. The alternative is to issue an areawide waiver for the entire affected jurisdiction. Such a waiver can be useful when the unacceptable noise zone heavily impacts a substantially developed community with limited site alternatives. (In most cases we would expect that the noise source would be aircraft, but in very small towns it is possible that a heavily used rail line could create a large unacceptable noise zone.)

An areawide EIS waiver would, of course, have to have a more detailed environmental assessment than an individual project request, and there are other special processing steps.

But if you have a situation where you think the Department has a good reason to expect to process a number of projects within the unacceptable noise zone, there is an alternative to Individual EIS waivers: Contact the Office of Environment and Energy for details on how to request the areawide waiver.

4. What exactly are the processing requirements and general policies for modernization and rehabilitation projects? Does section 51.104 apply to them as well as to new construction? The noise regulation is a bit confusing on this.

Yes, the noise regulation is a bit confusing on this question. We have seen several instances where field offices have mistakenly applied the provisions of Section 51.104 to modernization and rehabilitation projects. We believe that this happens because section 51.104 is not as clearly titled as it might have been. It would be better if it read "special requirements for new construction" rather than simply "special requirements".

The only parts of the regulation that apply to modernization and rehabilitation projects are sections 51.101 (a)(5) and the definitions of normally unacceptable and unacceptable noise zones contained in the table in section 51.103. None of the other processing or policy provisions of the table or of sections 51.102 and 51.104 apply. Therefore:

- modernization and rehabilitation projects are to be processed by the field offices regardless of the noise zone.

- EIS's are not required for modernization and rehabilitation projects unless mandated by other applicable environmental regulations.

You must however continue to encourage attenuation features in modernization and rehabilitation projects, in accordance with the general policy stated in section 51.101(a)(5).

5. We know that berms and barriers are the preferred type of noise attenuation because of the protection they provide for outdoor living areas, but we need some further guidance on when they are really the best choice.

While barriers can be an effective noise attenuation technique, they must, indeed, be used with caution and common sense because they can create more problems than they solve. Very high noise barriers can create significant aesthetic and financial problems relative to the noise benefit to be achieved. Barriers can block light, hinder natural ventilation, create an unpleasant sense of being walled in, and can be very unattractive. In addition, barriers do require continuing maintenance and can be very costly to build.

It is important to remember that the noise regulation says that "measures that reduce external noise at a site shall be used wherever practicable." Is it practicable to propose a 20 foot high barrier only 15 feet from the rear of a two-story building? Granted it would certainly protect the building from noise, but what about the blocked light, the reduced ventilation, the visual impact, and the cost? The purpose of a barrier is primarily to reduce the noise levels in those outdoor areas that people use. The secondary purpose is to reduce the need for structural attenuation. Therefore, the barrier should only be as high as is necessary to protect those areas. Structural attenuation should be required for the parts of the building not protected by the barrier. And if there aren't any outdoor areas where low noise levels are important, barriers shouldn't be required unless they would be more cost effective than building attenuation measures.

6. What should we be doing once we have processed new or revised aircraft noise contours and they have been approved for use?

The most important thing you can do once new or revised aircraft noise contours have been approved for use is to tell the people who are most likely to be affected by the change. If you have a newsletter that you regularly publish, that is one way to get the word out. At the very least you should specifically notify the affected jurisdictions and the builders/developers who are known to be active in the vicinity of the noise impacted areas. Make sure you notify builders and developers who have large scale projects that you have been processing in sections. Go back and check your files to find them. Even though you should have done an overall environmental review of the project at the time the first section was submitted, the approval of individual sections is dependent on the noise levels at the time that section is submitted.

Chapter 4 Noise Attenuation

Introduction

HUD's noise policy (24 CFR 51B) clearly requires that noise attenuation measures be provided when proposed projects are to be located in high noise areas. The requirements set out in Section 51.104(a) are designed to insure that interior levels do not exceed the $45 L_{dn}$ level established as a goal in Section 51.101(a)(9). Thus, in effect, if the exterior noise level is $65 L_{dn}$ to $70 L_{dn}$, 25 db of noise attenuation must be provided; if the exterior noise level is between 70 and $75 L_{dn}$, then 30 db of attenuation is required. Likewise, for projects proposed for areas where noise levels exceed $75 L_{dn}$, sufficient attenuation must be provided to bring interior levels down to $45 L_{dn}$ or below.

There are three basic ways to provide the noise attenuation required:

1. the use of barriers or berms
2. site design
3. acoustical construction

Of these, only the first two provide any improvement in the exterior environment. Because HUD considers a quiet exterior environment to be important, we prefer the use of those measures that reduce exterior levels as well as interior levels. The use of acoustical construction by itself is, therefore, the least preferred alternative since it only affects the interior levels. While we recognize that in many cases barriers or site design cannot provide all the attenuation necessary, you should combine them with acoustical construction whenever possible.

Your responsibility as a HUD staff member is to:

- make sure the project sponsor or developer is aware of the attenuation requirements for the project.
- make the sponsor aware of the options available and
- review attenuation proposals to make sure they are adequate.

While it is not your responsibility to provide detailed design assistance to the sponsor or developer, you should know enough about the attenuation options to give him or her a basic understanding of what must be done. In many cases, you may be able to reassure the sponsor or developer that the necessary attenuation can be achieved through the use of common construction techniques or materials. Or you may be able to point out how a simple site design change can achieve the desired result without additional cost.

The following sections are designed to provide you with the information you will need to fulfill your responsibilities. Each attenuation approach is discussed both in terms of basic concepts and in terms of what to look for in reviewing attenuation proposals. The discussion does assume that you have a working knowledge of the *Noise Assessment Guidelines*. If you have not worked with the *Guidelines* before or not recently you may want to go back and review them, particularly the section on calculating the effects of barriers.

Barrier Noise Reduction Concepts

(The following, with some editing and with some additional graphics, is taken from the Federal Highway Administration's *Noise Barrier Design Handbook*.¹)

When no obstacles are present between [a source] and adjoining areas, sound travels by a **direct path** from the "sources" ... to [the] "receivers" ..., as shown in Figure 1. Introduction of a barrier between the source and receiver redistributes the sound energy into several [indirect] paths: a **diffracted path**, over the top of the barrier; a **transmitted path**, through the barrier; and a **reflected path**, directed away from the receiver. These paths are also illustrated in Figure 1.

¹*Noise Barrier Design Handbook* US Department of Transportation, Federal Highway Administration, February 1976. (FHWA-RD-76-58).

Figure 1
Alteration of Noise Paths by a Barrier

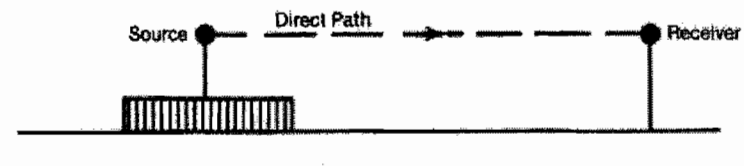
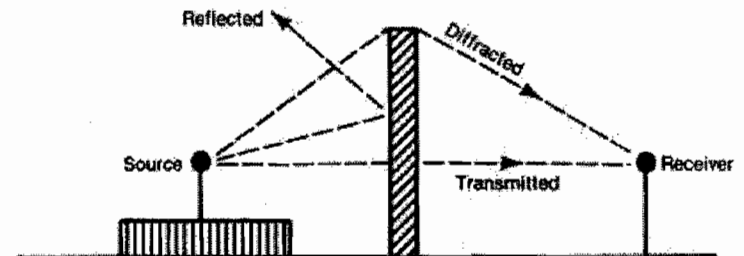

Barrier Diffraction and Attenuation

Consider an infinitely long, infinitely massive noise barrier placed between a highway and the receiver. Figure 2 illustrates a cross-section through such a configuration. [In] this example, the only way that sound can reach the receiver is by bending over the top of the barrier; as shown in the figure. The bending of sound waves in this manner over an obstacle is known as diffraction. The area in which diffraction occurs behind the barrier is known as the "shadow zone." The straight path from the source over the top of the barrier forms the boundary of this zone.

All receivers located in the shadow zone will experience some sound attenuation; the amount of attenuation is directly related to the magnitude of the diffraction angle ϕ . As ϕ increases, the barrier attenuation increases. The angle ϕ will increase if the barrier height increases, or if the source or receiver are placed closer to the barrier. Clearly then the barrier attenuation is a function of the geometrical relationship between the source, receiver, and barrier. One way of relating these parameters to the barrier attenuation is to define the path-length difference as shown in Figure 3. This parameter is the difference in distance that the sound must travel in diffracting over the top of the barrier rather than passing directly through it.

In the preceding discussion it was assumed that the barrier was "infinite"; i.e., long enough to shield the receiver from all sound sources up and down the highway. For short barriers, the attenuation can be seriously limited by the sound from sections of highway beyond the barrier's ends, which are unshielded from the receiver, as shown in Figure 4. Similarly, when there are large gaps in the barrier (to permit access, for example), sound from the unshielded section of highway adjacent to the gap can greatly compromise barrier attenuation, especially for those receivers close to the opening.

Figure 2
Barrier Diffraction

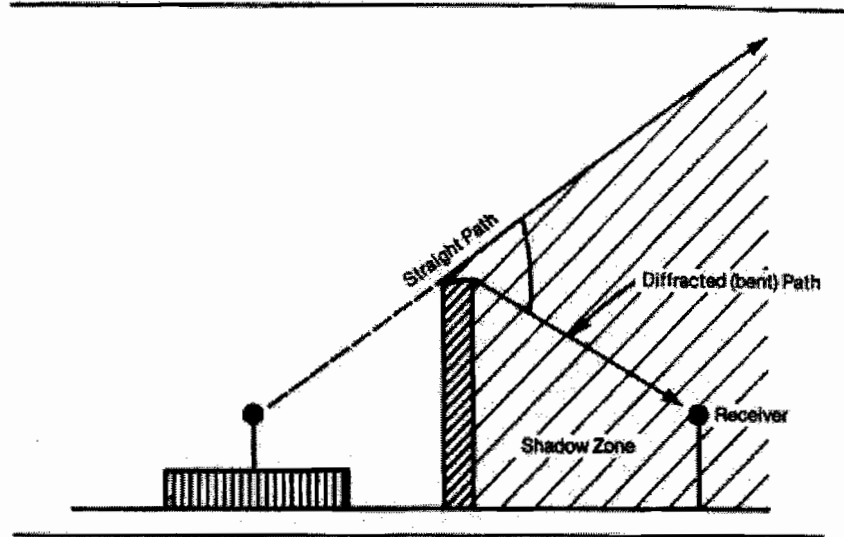

Figure 3
Path Length
Difference $\delta = A + B - d$

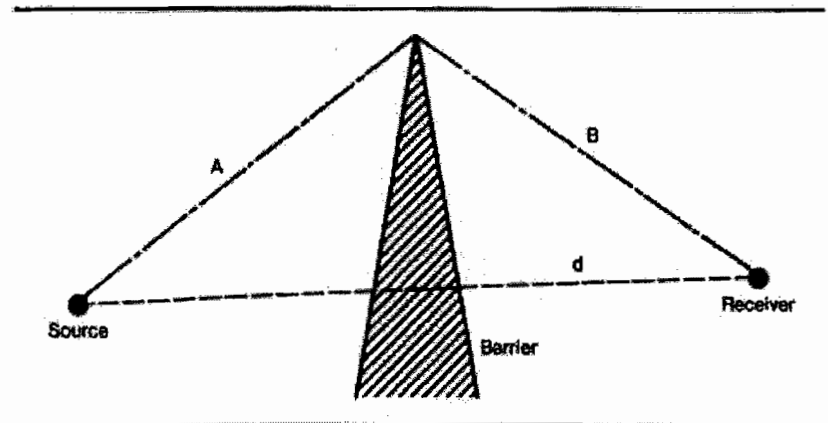
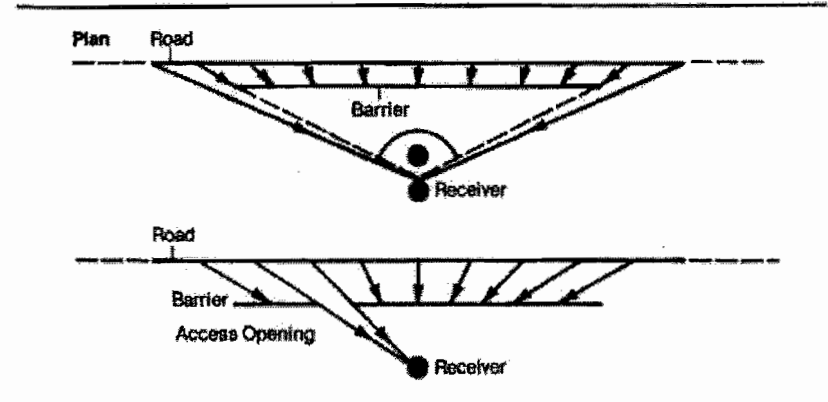

Figure 4
Short-circuit of Barrier Around Ends
and Through Openings



Barrier Transmission

In addition to the sound that travels over the top of the barrier to reach the receiver, sound can travel through the barrier itself. The amount of sound "transmission" through the barrier depends upon factors relating to the barrier material (such as its weight and stiffness), the angle of incidence of the sound, and the frequency spectrum of the sound. One way of rating a material's ability to transmit noise is by the use of a quantity known as the transmission loss, TL. The TL is related to the ratio of the incident noise energy to the transmitted noise energy. Transmission loss values are normally expressed in decibels and represent the amount noise levels will be reduced when the sound waves pass through the material. The higher the TL value the less noise transmitted through the material. Typically, the TL value improves with increasing surface weight of the material.

The noise reduction provided by a barrier can be severely compromised if the TL value of the material permits too much noise to pass through the barrier. This is due to the fact that when attenuation is a function of two or more factors, the noise level at the measurement point is actually the combination of the reduced noise levels resulting from each attenuation factor. For example, with a typical barrier the noise levels are reduced by (1) sound waves being diffracted over the barrier and (2) sound waves passing through the barrier. The noise level at the receiver point is the combination of the attenuated levels resulting from each attenuation step. If the starting noise level is 85 db and the noise level is reduced 10 db when the sound waves pass through the barrier then the attenuated level reaching the receiver is 55 db. If the attenuation provided by the sound waves being diffracted over the barrier is also 10 db then the attenuated level reaching the receiver along that path is 55 db as well. Using the table in the *Noise Assessment Guidelines* to combine the two individual attenuated levels, one finds that the combined attenuated level is actually 58 db. Thus even though the attenuation value of each attenuation step was 10 db, the actual reduction for the receiver is only 7 db. It is, however, a function of the way noise levels combine that if the difference between levels is greater than 10 db it does not affect the levels. As a general rule, therefore, if the TL value

is at least 10 dB above the attenuation value resulting from diffraction over the top of the barrier, the barrier noise reduction will not be significantly affected by transmission through the barrier (decreased by less than 0.5 dB). For many common materials used in barrier construction, such as concrete and masonry blocks, TL values are usually more than adequate. For less massive materials such as steel, aluminum and wood, TL values may not be adequate, particularly for those cases where large attenuations are required. (See Table 1 for a list of typical TL values.)

Even if a barrier material is massive enough to prevent significant sound transmission, the barrier noise reduction can be severely compromised if there are holes or openings in the barrier. For large openings, sound energy incident on the barrier will be directly transmitted through the opening to the receiver. When the opening is small an additional phenomenon occurs: upon striking the barrier wall the sound pressure will increase, resulting in an amplification of the transmitted sound to the receiver. Thus, the presence of openings or holes may seriously degrade the noise reduction provided by otherwise effective barriers.

Barrier Reflections

As shown in Figure 1, sound energy can be reflected by a barrier wall. For the configuration shown in that figure, the reflected energy does not affect the receiver, but may affect receivers located to the left of the highway. However the increase in noise level for these receivers would be less than 3 dB, because this single reflection can at most double the sound energy. (Remember how you combine noise levels? The most you add is 3 db when levels are the same.)

The situation is entirely different, however, when a double barrier situation is involved (refer to Figure 5). In addition to the energy that reaches the receiver by diffraction over the top of the barrier, if the barrier walls are reflective, additional sound energy can reach the receiver by a reflection from the left wall as illustrated in the figure. The same principles apply when there is a vertical retaining wall opposite a noise barrier; similarly, in a deep vertical cut the opposite walls will create multiple reflections.

If the barrier walls are not perfectly reflecting but absorb some of the sound energy, the contribution of each reflection is decreased by an amount that depends upon the absorptive characteristics of the barrier. For very hard, reflective surfaces, the absorption characteristics are very poor. Although a serious degradation in barrier performance may result for the double barrier situation, use of materials with good absorption values will usually recover all of the lost noise reduction.

Figure 5
Reflections from an
Opposing Barrier

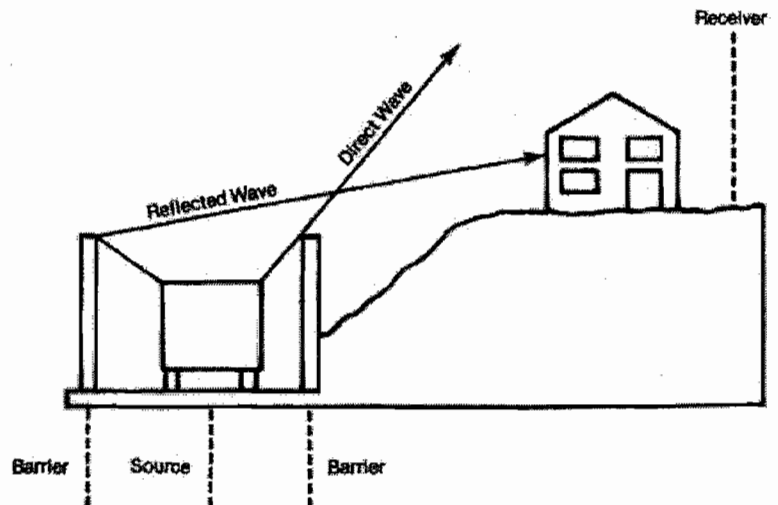

It should be mentioned that the use of barrier walls with sloped sides (forming angles of greater than 10–15 degrees from the vertical) will also generally eliminate multiple reflections. Use of earth berms is particularly appropriate to accomplish this. Sloped barrier walls will require more material to achieve a desired height than a vertical wall, while berms will require greater right-of-way than a thin wall.

Ground Effects

Consider again the direct path of sound from the source to receiver as illustrated in Figure 1 in the absence of any obstacles. For sources and receivers located close to the ground, in addition to this direct path sound energy may reach the receiver by reflecting off the ground. When the terrain is relatively hard and flat, such a reflection will add to the noise from the direct path to increase the level at the receiver. However, when the ground is soft, there may be a phase reversal upon reflection such that the noise from the ground reflection path will destructively interfere with the noise from the direct path resulting in a significant reduction in noise levels at the receiver.

This reduction in level, known as ground-effect attenuation, is in excess of the 3 dB per doubling of distance propagation loss for a line source of noise and occurs only above soft absorptive ground (such as normal earth and most ground with vegetation). Over hard ground (such as concrete, stone and very hard-packed earth) these effects do not occur. These effects are most apparent for receivers on the ground floor, and decrease rapidly as receiver height above ground increases.

While ground absorption effects are not completely understood, it is generally believed that these effects account for the 4.5 dB per doubling of distance propagation loss observed over soft ground, as compared to the 3 dB propagation loss observed over hard ground. The implication with regard to barrier design is that placement of a barrier over soft ground between source and receiver will re-direct the sound over the top of the barrier, thus destroying the ground reflection and the additional 1.5 dB per doubling of distance attenuation. Thus, the barrier must be designed to provide more reduction than would otherwise be necessary, to compensate for the lost ground effects over absorptive ground.

Summary

(From: *Design Guide*, National Bureau of Standards¹)

In summary, the following can be said about noise barriers.

- If a barrier does not block the line-of-sight between the source and receiver, the barrier will provide little or no attenuation.
- If a barrier is constructed of a material with a surface weight density greater than 4 lb/ft² and there are no openings through the barrier, transmitted sound will usually be negligible.
- If there are openings totaling over 10 percent or more of the barrier area, barrier attenuation will be negligible.
- Diffracted sound is usually the most important aspect in estimating barrier attenuation.
- Reflected sound can be important for receivers on the source side of a barrier, but it normally is not a factor for receivers on the side opposite from the source. Hence reflected sound is usually not important to your building and site.
- Transmission of sound around the ends of the barrier can be critical if the barrier included angle is less than 170°.
- Barrier attenuations greater than an A-weighted sound level difference of 10 dB are difficult to obtain.
- For two or more barriers "in series," consider only the "dominant" barrier.
- Assume no attenuation for a receiver located beyond the end of a barrier.

Reviewing Barrier Proposals

An effective barrier is one which reduces the noise level behind the barrier to 65 L_{dN} or lower. If a barrier can reduce the exterior noise level to 65 L_{dN}, then standard construction techniques should be sufficient to insure an interior level of 45 L_{dN} or below. Therefore, if you determine that a proposed barrier is adequate to reduce the exterior noise level to 65 L_{dN} then no additional attenuation measures should be necessary.

¹*Design Guide for Reducing Transportation Noise in and Around Buildings*, US Department of Commerce, National Bureau of Standards, April 1978. (Building Science Series 84)

There are four things to check when determining the adequacy of a proposed barrier:

1. Is it high enough?
2. Is it long enough?
3. Is it made of the right materials?
4. Is it properly constructed?

Is It High Enough?

In order for a barrier to be effective it must be at least high enough to break the line of sight between the source and the receiver. In the *Noise Assessment Guidelines* you will find the procedure for determining how much attenuation is provided by a barrier of a given height.

In general, barriers and berms are most effective for one and two story buildings because a relatively low barrier can often provide the attenuation needed. The height that might be required to provide attenuation for much taller buildings is often not feasible for either cost or aesthetic reasons. However, even if a barrier can not be made high enough to attenuate the upper floors of a multistory building, it may still be able to provide some protection for outdoor recreational areas. Before discarding the barrier idea check for this possibility.

If you find that the barrier as proposed is too short to be effective but the sponsor or developer tells you that he or she can not make the barrier any higher, there are some alternatives you can suggest. There are ways to get more attenuation out of each foot of overall height.

As a general rule, barriers work better the closer they are to the source. Figure 6 shows a barrier that does not block the line of sight at all when it is located next to the receiver, yet is quite tall enough when located next to the source. Thus, if the sponsor or developer can not make the barrier any taller, perhaps he or she can move it closer to the source.

Another way to get more attenuation without increasing overall barrier height is to bend the top of the barrier towards the source. Figure 7 shows a case where a barrier built perfectly straight provides 8 dB of attenuation. A barrier with the same overall height but with a 45 degree bend towards the source provides 9.5 dB of attenuation. Thus if the project sponsor or developer wants to keep the overall height of the barrier down, he or she can still increase the attenuation provided simply by bending the top.

Figure 6
Effect of Moving the Barrier
Closer to the Source

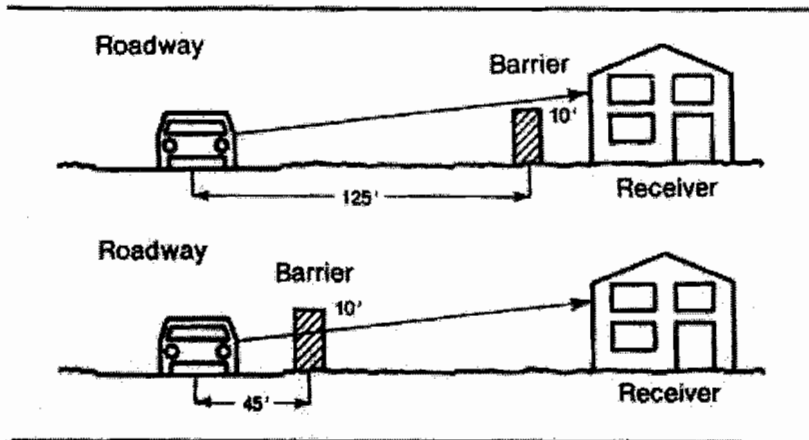
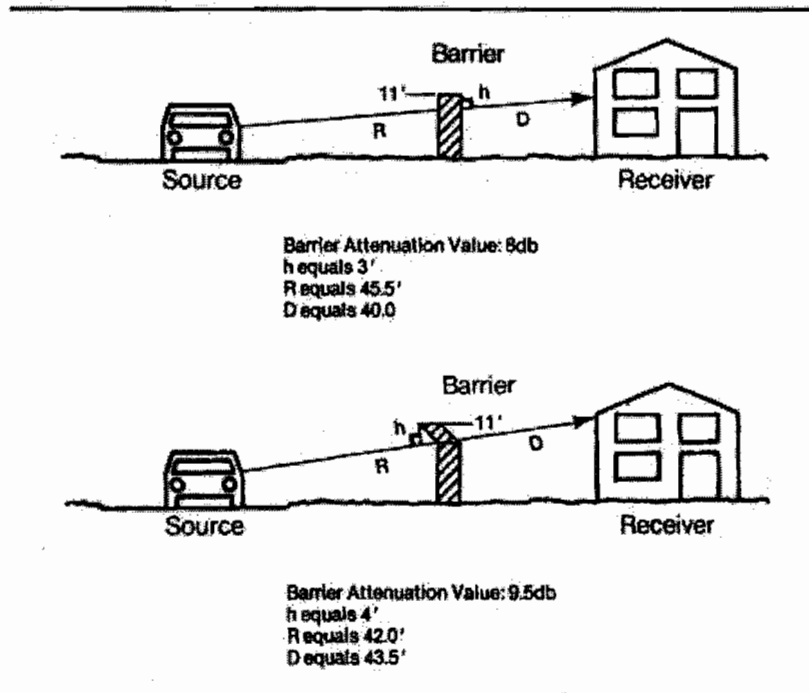

Figure 7
Effect of Bending the Top of the
Barrier Towards the Source



Thus, if your review of a proposed barrier shows it to be too short, but it can not be made any higher, suggest that the barrier be moved closer to the source or that it be bent at the top, or both.

Is It Long Enough?

Once you have established how much attenuation the barrier provides due to its height, you must determine if the length of the barrier compromises that attenuation level. Again, the *Noise Assessment Guidelines* contain a procedure for calculating the effect of barrier length.

If you find that the barrier is too short but that there are limitations on how long it can be made, there are, as there were with barrier heights, some recommendations you can make on how to improve the effectiveness of the barrier.

Again, if you bend the edges of the barrier, this time towards the receiver not the source, you will increase the effectiveness of the barrier. Figure 8 shows how much a barrier's effectiveness can be improved by bending the edges.

You can also improve the effectiveness of the barrier by moving it closer to the receiver. Figure 9 shows how much a barrier's effectiveness can be increased by moving it closer to the receiver. Now obviously, this creates a conflict with what we said earlier about moving the barrier closer to the source. Clearly each case will require a different compromise. If height is not a limiting factor but length is, you might recommend to the project sponsor or developer that the barrier be moved closer to receiver and the height increased as necessary. If the reverse is true, you would want to recommend the opposite. If both height and length are limited, then the sponsor or developer must find that optimum point where the effectiveness of both the barrier height and the barrier length is as high as possible.

Figure 8
Effect of Bending the Edges of Barrier
Towards Receiver
(Both Barriers have Potential Value of 10db)

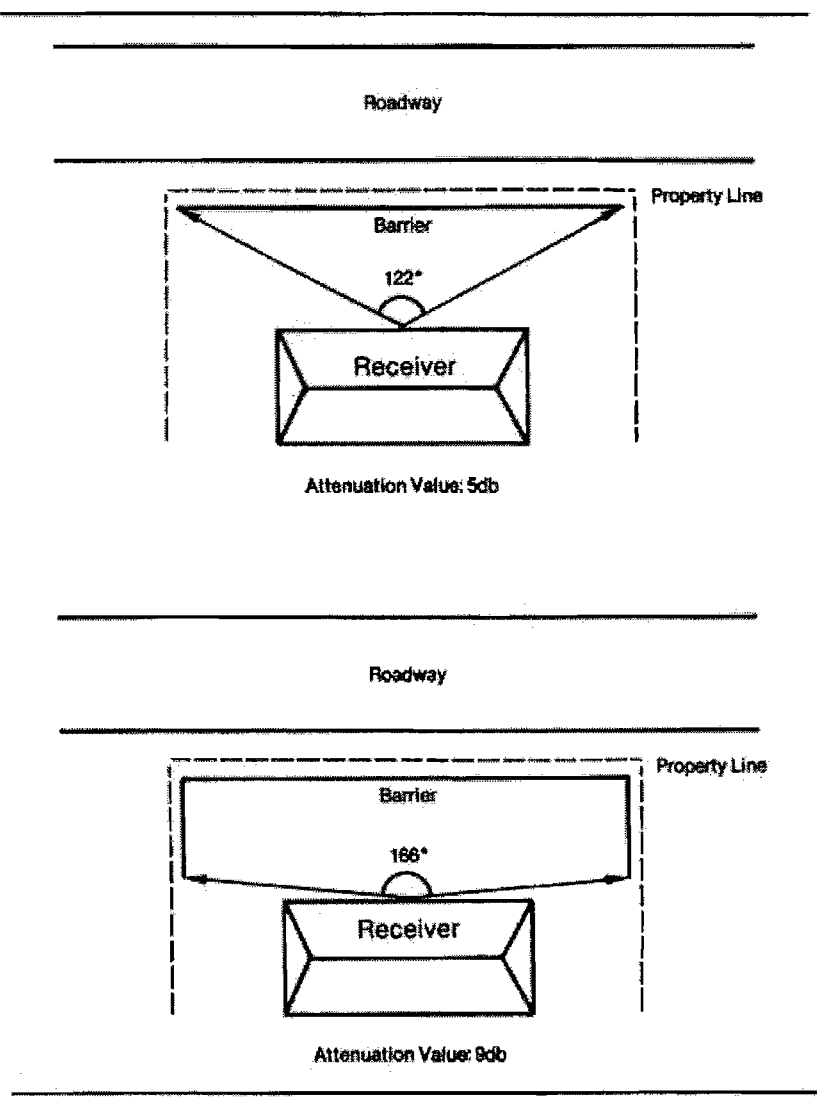

Is It Made of The Right Materials?

Even if a barrier is high enough and long enough, its effectiveness can be severely reduced if it is made up of lightweight materials that easily transmit sound waves. In the preceding section on barrier concepts we talked about how if the transmission loss value for the barrier material was not at least 10 db higher than the attenuation value of the barrier based on length and height there would be a significant reduction in the effectiveness of the barrier.

Therefore, once you have calculated the basic attenuation potential of the barrier, you must check to make sure the proper material is being used to build the barrier. Table 1 lists the transmission loss values for materials commonly used in barrier construction. Once you have found the transmission loss value for the material being used, go to Table 2. Read down the column with the transmission loss for the material at its top and across the line that has the attenuation potential for the barrier listed. Where the two intersect you will find the actual attenuation capability of the barrier.

If you find that the choice of material has severely reduced the effectiveness of the barrier, you should recommend that the sponsor or developer select another material.

Is It Properly Constructed?

Holes or openings can substantially reduce the effectiveness of a barrier. A barrier that has openings totaling 50% or more of its total area will provide no attenuation. A barrier that has openings totaling 10% of its total area has a maximum attenuation value of approximately 4db. That is 4db no matter how high, how long or how thick the barrier. So you can see that it is very important that the barrier is made of solid materials and that it is tightly constructed. In general the intended openings in a barrier should equal no more than 1% of total area and the construction specifications should require that all joints are tightly sealed.

Figure 9
Effect of Moving Barrier
Closer to Receiver

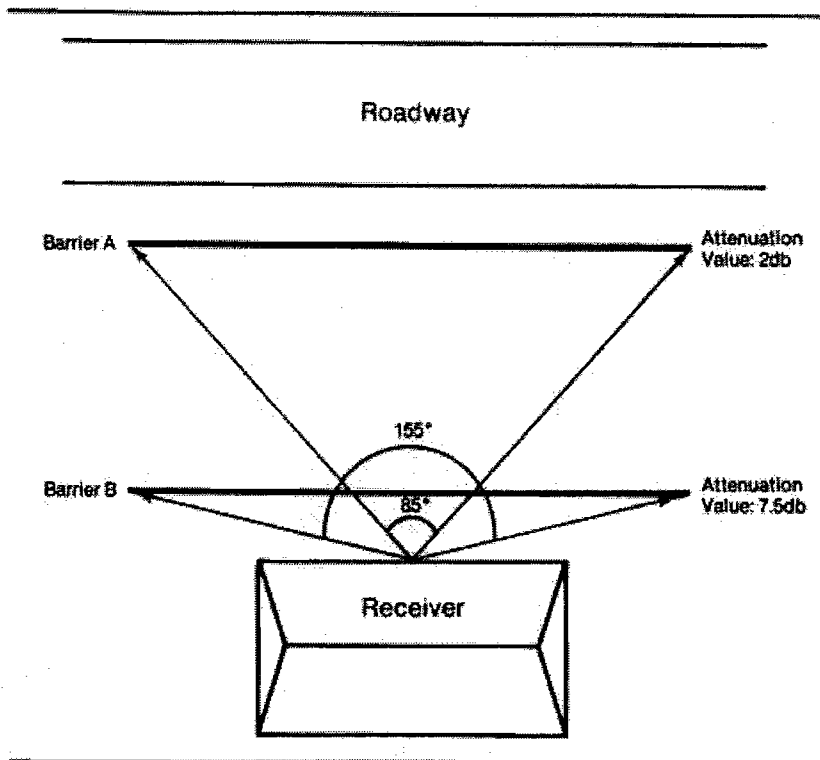

A Final Note

One thing should have become clear to you as you have been reading this section, and that is that in order for you to adequately review a project sponsor or developer's proposed barrier you must be given fairly specific information about the exact dimensions of the proposed barrier, the type and thickness of the barrier material, and the exact design of the barrier including construction specifications. Without this information you will be unable to do any more than a cursory evaluation, an evaluation that could be far from accurate. Make sure you make it clear to the developer or sponsor what you need to have.

Table 1
Transmission Loss Value for Common
Barrier Materials

| Material | Thickness, (Inches) | Transmission Loss, dBA (1) |
|----------------------------------|---------------------|----------------------------|
| Woods | | |
| Fir | 1/2 | 17 |
| | 1 | 20 |
| | 2 | 24 |
| Pine | 1/2 | 16 |
| | 1 | 19 |
| | 2 | 23 |
| Redwood | 1/2 | 16 |
| | 1 | 19 |
| | 2 | 23 |
| Cedar | 1/2 | 15 |
| | 1 | 18 |
| | 2 | 22 |
| Plywood | 1/2 | 20 |
| | 1 | 23 |
| Particle Board | 1/2 | 20 |
| Metals | | |
| Aluminum | 1/16 | 23 |
| | 1/8 | 25 |
| | 1/4 | 27 |
| Steel | 24 ga | 18 |
| | 20 ga | 22 |
| | 16 ga | 15 |
| Lead | 1/16 | 28 |
| Concrete, Masonry, etc. | | |
| Light Concrete | 4 | 36 |
| | 6 | 39 |
| Dense Concrete | 4 | 40 |
| Concrete Block | 4 | 32 |
| | 6 | 36 |
| Cinder Block (Hollow Core) | 6 | 28 |
| Brick | 4 | 33 |
| Granite | 4 | 40 |
| Composites | | |
| Aluminum Faced Plywood | 3/4 | 21-23 |
| Aluminum Faced Particle Board | 3/4 | 21-23 |
| Plastic | | |
| Lamina on Plywood | 3/4 | 21-23 |
| Plastic Lamina on Particle Board | 3/4 | 21-23 |
| Miscellaneous | | |
| Glass (Safety Glass) | 1/8 | 22 |
| | 1/4 | 26 |
| Plexiglass (Shatterproof) | | 22-25 |
| Masonite | 1/2 | 20 |
| Fiberglass/Resin | 1/8 | 20 |
| Stucco on Metal Lath | 1 | 32 |
| Polyester with Aggregate Surface | 3 | 20-30 |

¹A-weighted TL based on generalized truck spectrum. Source: *Noise Barrier Design Handbook*, FHWA

Table 2
Noise Reduction of a Barrier as a
Function of Its Transmission Loss

| Designed Attenuation, dB (from height) and length) | Transmission Loss, dB of Materials | | | | |
|---|------------------------------------|------|------|------|------|
| | 10 | 15 | 20 | 25 | 30 |
| 5 | 3.8 | 4.6 | 4.9 | 5.0 | 5.0 |
| 6 | 4.5 | 5.5 | 5.8 | 6.0 | 6.0 |
| 7 | 5.2 | 6.4 | 6.8 | 6.9 | 7.0 |
| 8 | 5.9 | 7.2 | 7.7 | 7.9 | 8.0 |
| 9 | 6.5 | 8.0 | 8.7 | 8.9 | 9.0 |
| 10 | 7.0 | 8.8 | 9.6 | 9.9 | 10.0 |
| 11 | 7.5 | 9.5 | 10.5 | 10.8 | 11.0 |
| 12 | 7.9 | 10.2 | 11.4 | 11.8 | 11.9 |
| 13 | 8.2 | 10.9 | 12.2 | 12.7 | 12.9 |
| 14 | 8.5 | 11.5 | 13.0 | 13.7 | 13.9 |
| 15 | 8.8 | 12.0 | 13.8 | 14.6 | 14.9 |
| 16 | 9.0 | 12.5 | 14.5 | 15.5 | 15.8 |
| 17 | 9.2 | 12.9 | 15.2 | 16.7 | 16.8 |
| 18 | 9.4 | 13.2 | 15.9 | 17.2 | 17.7 |
| 19 | 9.5 | 13.5 | 16.5 | 18.0 | 18.7 |
| 20 | 9.6 | 13.8 | 17.0 | 18.8 | 19.6 |

Source: *Noise Barrier Design Handbook*, FHWA

Acoustical Site Planning Concepts

(This section, with some editing, is from *The Audible Landscape*, FHWA.)

The arrangement of buildings on a site can be used to minimize noise impacts. If incompatible land uses already exist, or if a noise sensitive activity is planned, acoustical site planning often provides a successful technique for noise impact reduction.

Many site planning techniques can be employed to shield a residential development from noise. These can include:

1. increasing the distance between the noise source and the receiver;
2. placing noise compatible land uses such as parking lots, maintenance facilities, and utility areas between the source and the

receivers. Playgrounds and parks are not necessarily noise compatible activities.

3. locating barrier-type buildings parallel to the noise source or the highway; and
4. orienting the residences away from the noise.

The implementation of many of the above site planning techniques can be combined through the use of cluster and planned unit development techniques.

Distance

Noise can be effectively reduced by increasing the distance between a residential building and a highway. Distance itself reduces sound: doubling the distance from a noise source can reduce its intensity by as much as 3 dBA. In the case of highrise buildings, distance may be the only

means, besides acoustical design and construction, of reducing noise impacts. This is because it is nearly impossible to provide physical shielding for the higher stories from adjacent noise.

Noise Compatible Land Uses as Buffers

Noise protection can be achieved by locating noise-compatible land uses between the highway and residential units. Whenever possible, compatible uses should be nearest the noise source. Figure 10 shows a proposed parking garage along two sides of a development in Boston. Both the

The Audible Landscape: A Manual for Highway Noise and Land Use, US Department of Transportation, The Federal Highway Administration, November 1974. (GPO Stock Number: 5000-00079.)

Figure 10
Use of a Parking Garage to
Shield a Residential Area

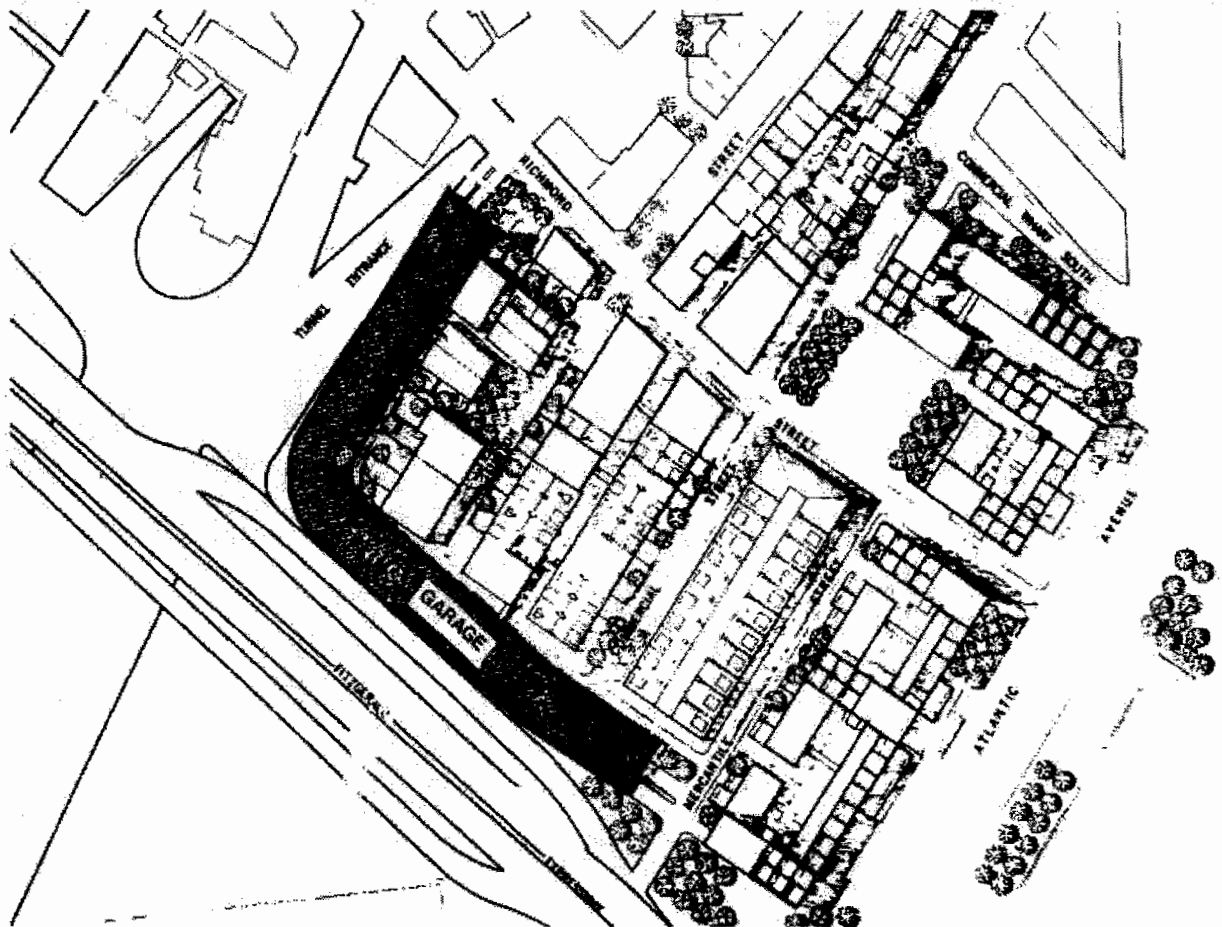

Fitzgerald Expressway and the entrance to the Callahan Tunnel which are shown on the site plan are major and noisy traffic routes. In addition to protecting the residential development from the noise and dirt of highway traffic, the parking garage provides needed facilities for the residents.

Buildings as Noise Shields

Additional noise protection can be achieved by arranging the site plan to use buildings as noise barriers. A long building, or a row of buildings parallel to a highway can shield other more distance structures or open areas from noise.

If the building being used as a barrier is sensitive to highway noise, the building itself must first be soundproofed. This technique was used in a housing project in England where a 3,900 foot long, 18 foot wide and 45-70 foot high wall (depending on the terrain) serves as both residence and a sound shield. The wall/building will contain 387 apartments in which the kitchens and bathrooms are placed towards the noise, and the bedrooms and living rooms face away from the highway. The wall facing the highway will be soundproofed and windows, when they exist, are sealed. Substantial noise reductions are expected.

Orientation

The orientation of buildings or activities on a site affects the impact of noise, and the building or activity area may be oriented in such a way as to reduce this impact.

Noise impacts can be severe for rooms facing the roadway since they are closest to the noise source. The noise impact may also be great for rooms perpendicular to the roadway

Figure 11
Conventional Grid Subdivision

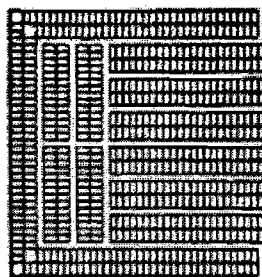

because (a) the noise pattern can be more annoying in perpendicular rooms and (b) windows on perpendicular walls do not reduce noise as effectively as those on parallel walls because of the angle of the sound. Road noise can be more annoying in perpendicular rooms because it is more extreme when it suddenly comes in and out of earshot as the traffic passes around the side of the building, rather than rising and falling in a continuous sound, as it would if the room were parallel to passing vehicles.

Whether the noise impact is greater on the perpendicular or the parallel wall will depend on the specific individual conditions. Once the most severely impacted wall or walls are determined, noise impacts may be minimized by reducing or eliminating windows from these walls.

Buildings can also be oriented on a site in such a way as to exploit the site's natural features. With reference to noise, natural topography can be exploited and buildings placed in low noise pockets if they exist. If no natural noise pockets exist, it is possible to create them by excavating pockets for buildings and piling up earth mounds between them and the noise. Such a structure would obstruct the sound paths and reduce the noise impacts on the residences.

Cluster and Planned Unit Development

A cluster subdivision is one in which the densities prescribed by the zoning ordinance are adhered to but instead of applying to each individual parcel, they are aggregated over the entire site, and the land is developed as a single entity. A planned unit development, or P.U.D., is similar but changes in land use are included, such as apartments and commercial facilities in what would otherwise be a single-family district.

From Figure 11 it can be seen how the conventional grid subdivision affords no noise protection from the adjacent highway. The first row of houses bears the full impact of the noise. In contrast, the cluster and P.U.D. techniques enable open space and commercial uses respectively to serve as noise buffers. Examples of this are shown in Figures 12 and 13. A word of caution is necessary: In a cluster development, the required open space can be located near the highway to minimize noise to the residences. However, many recreation uses are noise sensitive, and when one takes advantage of the flexibility of cluster development to minimize noise, care must be taken not to use all of the available open space in

Figure 12
Placement of Noise Compatible Uses Near a Highway in a PUD

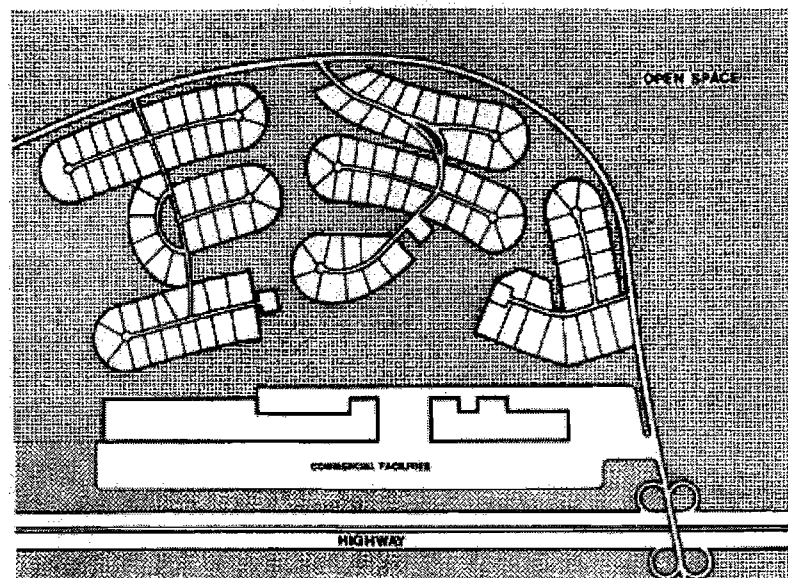

buffer strips, thus depriving the development of a significant open space area. Where high noise levels exist, a combination of buffer strips and other techniques (such as berms and acoustical sound proofing) can be employed.

The flexibility of the cluster and planned unit development techniques allows many of the above site planning techniques to be realized and effective noise reduction achieved.

Reviewing Site Plans

There are two main things to check when reviewing site plan changes to determine if the revised site plan provides adequate attenuation for the noise sensitive uses:

1. Is the separation between the source and the receiver great enough?
2. If noise-compatible buildings are being used as barriers for other buildings, are they adequate barriers, i.e., are they long enough and are they high enough? (And, if the buildings

being used as barriers contain noise sensitive activities, have the buildings been properly soundproofed.)

In order to determine whether the proposed site plan changes will provide adequate separation between the source and the receiver, you simply go back to the *Noise Assessment Guidelines* procedures. You can use the *Guidelines* both to determine if the proposed separation distance is sufficient or to determine the necessary separation distance. You should at this point check to make sure that the uses being located in the "buffer zone" between the source and the receiver are indeed noise compatible uses. If parks or playgrounds are located in the buffer zone, make sure they are not the only ones associated with the project.

To determine whether the noise compatible buildings being proposed as barriers are adequate, you simply use the procedures outlined in the preceding section. Determine whether the building is high enough to properly break the line of sight

between the receiver and the source. Then determine if the building is long enough. It is not necessary to check to make sure it is made of the proper materials or that it is properly constructed since the building will be inherently thick enough not to have any problems. Again, however, if the building being proposed as a barrier contains noise sensitive uses you must first verify that it is properly soundproofed. (See the next section for guidance on acoustical construction.) If the building is not properly soundproofed then it can not be used as a barrier for other buildings.

As you review the site plan check to see that the building locations will not aggravate noise problems. Figure 14 shows how building arrangement can make the noise problem worse.

Figure 13
Open Space Placed Near a Highway in a Cluster Development

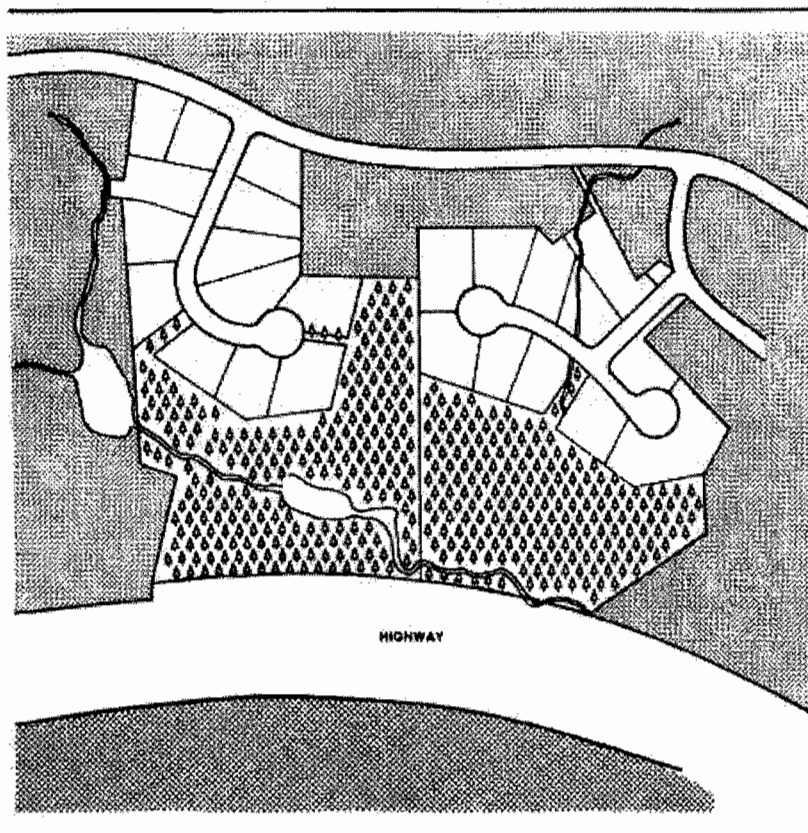
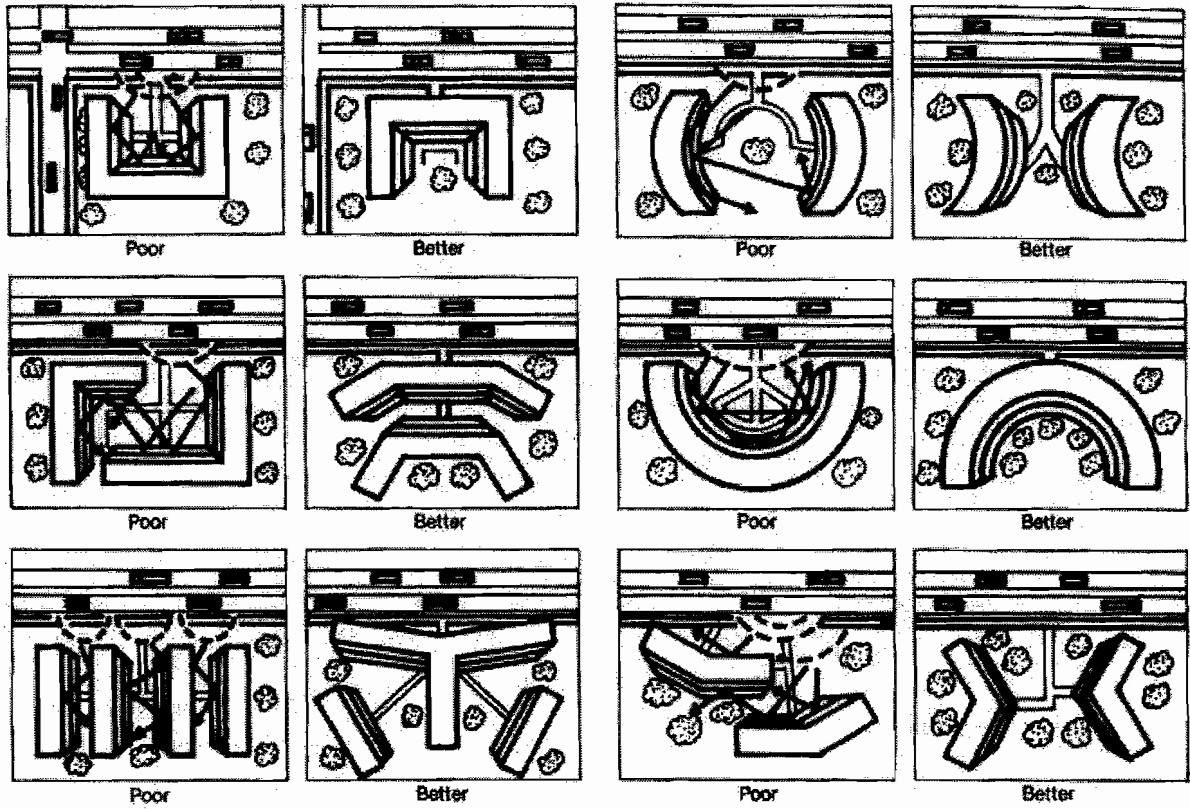

Figure 14
Orientation of Buildings on Sites



Acoustical Construction Concepts

(This section, with some editing is taken from the *Audible Landscape*, FHWA.¹)

Noise can be intercepted as it passes through the walls, floors, windows, ceilings, and doors of a building. Examples of noise reducing materials and construction techniques are described in the pages that follow.

To compare the insulation performance of alternative constructions, the Sound Transmission Class (STC) is used as a measure of a material's ability to reduce sound. Sound Transmission Class is equal to the number of decibels a sound is reduced as it passes through a material. Thus, a high STC rating indicates a good insulating material. It takes into account the influence of different frequencies on sound transmission, but essentially the STC is the difference between the sound levels on the side of the partition where the noise originates and the side where it is received. For example, if the external noise level is 85 dB and the desired internal level is 45 dB, a partition of 40 STC is required. The Sound Transmission Class rating is the official rating endorsed by the American Society of Testing and Measurement. It can be used as a guide in determining what type of construction is needed to reduce noise.

The use of the STC rating system for transportation noise is a subject of some debate. The STC rating was originally intended primarily for use with interior partitions and relates to the "subjective impressions of the sound insulation provided against the sounds of speech, radio, television, music, and similar sources of noise in offices and dwellings."² However, since it remains the only widely used noise reduction rating system for materials the STC system is very often used even with transportation noise. When STC ratings are used for transportation noise you should be aware that the STC ratings may be a few dB too high. For example, the STC rating for a standard frame 2 x 4 wall with exterior siding, and sheathing and interior sheetrock may be 37 dB.³

If rated specifically for transportation noise the dB reduction rating might drop to 34 dB.⁴ All this really means, however, is that you should use the STC ratings with a bit of caution and remain aware of the possible 2-3 dB overstating that you may get with the STC rating system. Throughout this text we will be talking in terms of STC ratings for materials and assemblies.

¹The Audible Landscape: A Manual for Highway Noise and Land Use, US Department of Transportation, the Federal Highway Administration, November 1974, (GPO Stock #5000-00079).

²Acoustical and Thermal Performance of Exterior Residential Walls, Doors, and Windows, US Department of Commerce, National Bureau of Standards, November 1975. (NBS Building Science Series 77) page 21.

³Ibid., p. 29

⁴Design Guide for Reducing Transportation Noise In and Around Buildings, p. 137.

Walls

Walls provide building occupants with the most protection from exterior noise. Different wall materials and designs vary greatly in their sound insulating properties. Figure 15 provides a visual summary of some ways in which the acoustical properties can be improved:

Increase the mass and stiffness of the wall. In general, the denser the wall material, the more it will reduce noise. Thus, concrete walls are better insulators than wood walls of equal thickness. Increasing the thickness of a wall is another way to increase mass and improve sound insulation. Doubling the thickness of a partition can result in as much as a 6 dB reduction in sound.⁵ However, the costs of construction tend to limit the feasibility of large increases in wall mass.

The relative stiffness of the wall material can influence its sound attenuation value. Care must be taken to avoid wall constructions that can vibrate at audible frequencies and transmit exterior sounds.

⁵R. K. Cooke and P. Chrzanowski, "Transmission of Noise Through Walls and Floors," Cyril Harris, ed., Handbook of Noise Control, McGraw-Hill Book Company, Inc. (New York, 1957).

Figure 15
The Audible Landscape

Factors which influence sound attenuation of walls

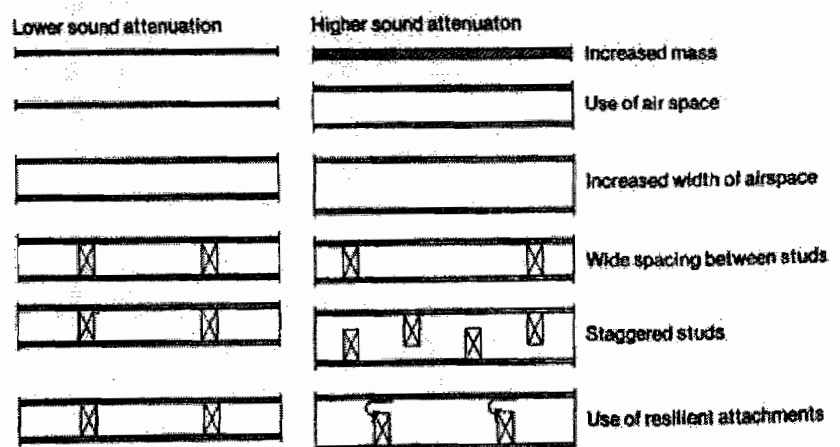

Use cavity partitions. A cavity wall is composed of two or more layers separated by an airspace. The airspace makes the cavity wall a more effective sound insulator than a single wall of equal weight, leading to cost savings.

Increase the width of the airspace. A three inch airspace provides significant noise reduction, but increasing the spacing to six inches can reduce noise levels by an additional 5 dBA. Extremely wide airspaces are difficult to design.

Increase the spacing between studs. In a single stud wall, 24 inch stud spacing gives a 2-5 dB increase in STC over the common 16 inch spacing.²

Use staggered studs. Sound transmission can be reduced by attaching each stud to only one panel and alternating between the two panels.

Use resilient materials to hold the studs and panels together. Nails severely reduce the wall's ability to reduce noise. Resilient layers such as fiber board and glass fiber board, resilient clips, and semi-resilient attachments are relatively inexpensive, simple to insert, and can raise the STC rating by 2-5 dB.¹

Use dissimilar layers. If the layers are made of different materials and/or thickness, the sound reduction qualities of the wall are improved.²

Add acoustical blankets. Also known as isolation blankets, these can increase sound attenuation when placed in the airspace. Made from sound absorbing materials such as mineral or rock wool, fiberglass, hair felt or wood fibers, these can attenuate noise as much as 10 dB.³ They are mainly effective in relatively lightweight construction.

Seal cracks and edges. If the sound insulation of a high performance wall is ever to be realized, the wall must be well sealed at the perimeter. Small holes and cracks can be devastating to the insulation value of a wall. A one-inch square hole or a 1/16 inch crack 18 inches long will reduce a 50 STC wall to 40.⁴

Figure 16 shows a sample of wall types ranging from the lowest to the highest sound insulation values.

Remember that the effectiveness of best wall construction will be substantially reduced if you permit vents, mail slots or similar openings in the walls. If vents are permitted the ducts must be specially designed and insulated to make sure noise does not reach the inside. The best approach is simply to eliminate all such openings on impacted walls.

¹Ibid, p. 172

²Ibid, p. 182

³Doelle, p. 20

⁴United States Gypsum, Sound Control Construction, Principles and Performance (Chicago, 1972), p. 66

²Leslie T. Doelle, Environmental Acoustics (New York, McGraw-Hill Book Company, 1972), pp. 232-233.

Figure 16
Walls

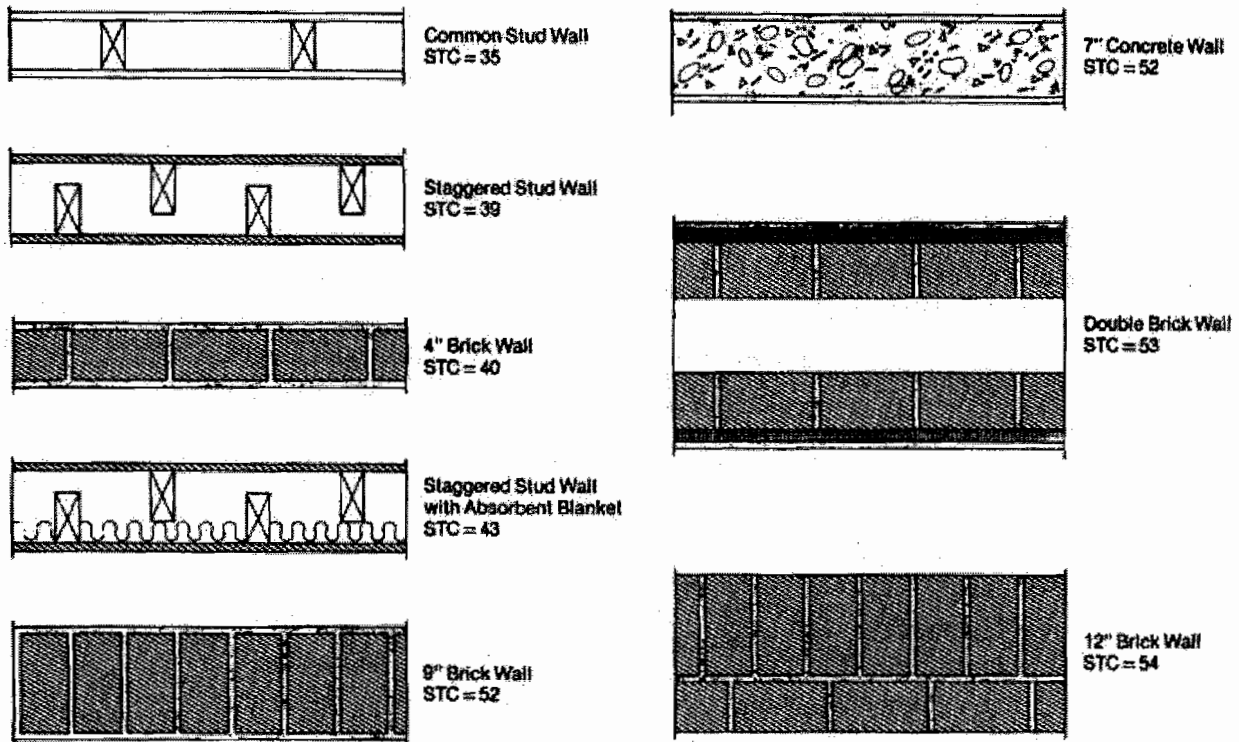

Windows

Sound enters a building through its acoustically weakest points, and windows are one of the weakest parts of a wall. An open or weak window will severely negate the effect of a very strong wall. Whenever windows are going to be a part of the building design, they should be given acoustical consideration. Figure 17 illustrates the effects of windows on the sound transmission of walls. For example, if a wall with an STC rating of 45 contains a window with an STC rating of 26 covering 30% of its area, the overall STC of the composite partition will be 35, a reduction of 10 dB.

The following is a discussion of techniques that can be used to reduce noise in a building by means of its windows. These techniques range from a blocking of the principal paths of noise entry to a blocking of the most indirect paths.

Close windows. The first step in reducing unwanted sound is to close and seal the windows. The greatest amount of sound insulation can be achieved if windows are permanently sealed. However, operable acoustical windows have been developed which are fairly effective in reducing sound.¹ Whether or not the sealing is permanent, keeping windows closed necessitates the installation of mechanical ventilation systems. If you are dealing with single family houses and some of the windows are facing away from all noise sources, a whole house fan may be better and cheaper than air conditioning. In multifamily housing or where all windows are exposed to the noise sources you will have to go with the air conditioning. If windows must be openable, special seals are available which allow windows to be opened.²

Reduce window size. The smaller the windows, the greater the transmission loss of the total partition of which the window is a part. Reducing the window size is a technique that is used because (a) it precludes the cost of expensive acoustical windows, and (b) it saves money by cutting down the use of glass. The problems with this technique are (a) it is not very effective in reducing noise; e.g., reducing the proportion of window to wall size from 50% to 20% reduces noise by only 3 decibels; and (b) many building codes require a minimum window to wall size ratio.

Figure 17
STC

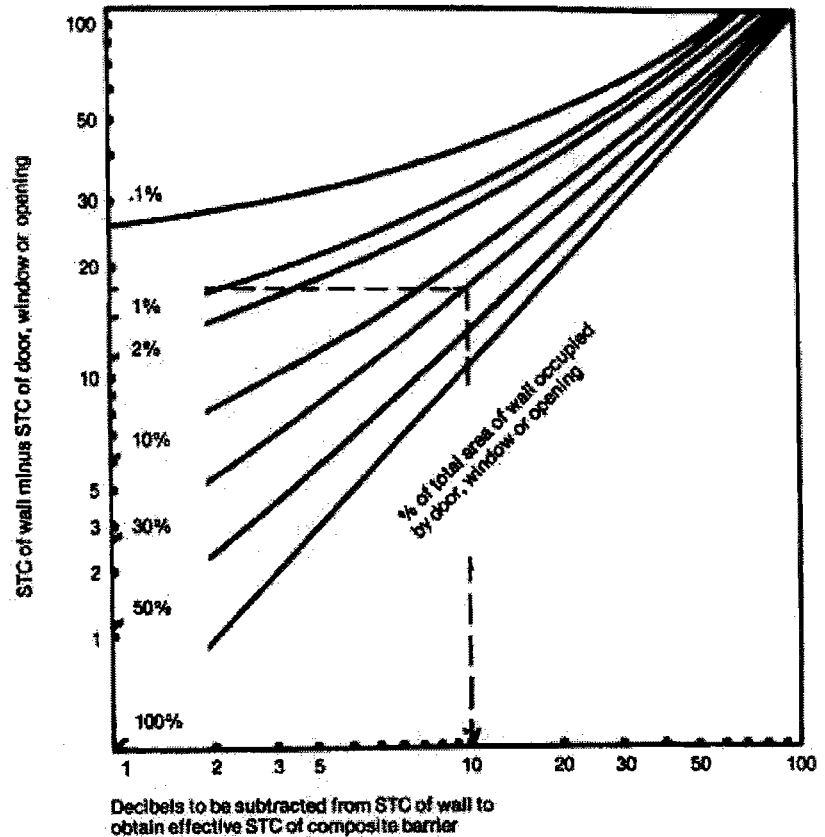

Instructions on use of graph

1. Subtract the STC value of the door, window or opening from the STC value of the wall.
2. Enter the vertical axis of the graph at the point that matches the value from step 1.
3. Read across to the curve that represents the percentage of the total area of the wall that is taken up by the door, window, or opening.
4. Read down to the horizontal axis.
5. Subtract the value on the horizontal axis from the original STC value of the wall. The result is the composite STC value of the wall and the door, window or opening.

Increase glass thickness. If ordinary windows are insufficient in reducing noise impacts in spite of sealing techniques, then thicker glass can be installed. In addition, this glass can be laminated with a tough transparent plastic which is both noise and shatter resistant. Glass reduces noise by the mass principle; that is, the thicker the glass, the more noise resistant it will be. A 1/2-inch thick glass has a maximum STC rating of 35 dB compared to a 25 dB rating for ordinary 3/16 inch glass.

¹U.S. Department of Housing and Urban Development, A Study of Techniques to Increase the Sound Insulation of Building Elements, Report No. WR 73-5, Washington, D.C., June 1973.

²Los Angeles Department of Airports, Guide to the Soundproofing of Existing Homes Against Exterior Noise, Report No. WRC 70-2, March 1970, pp. 9-11, 22-30. In this report, the function and performance of a number of operable seals are described.

However, glass thicknesses are only practical up to a certain point, when STC increases become too insignificant to justify the cost. For example, a 1/2 inch thick glass can have an STC of 35; increasing the thickness to 3/4 inch only raises the STC to 37. However, a double glass acoustical window consisting of two 3/16 inch thick panes separated by an airspace will have an STC of 51 and can cost less than either solid window.

In addition to thickness, proper sealing is crucial to the success of the window. To prevent sound leaks, single windows can be mounted in resilient material such as rubber, cork, or felt.

Install Double-Glazed Windows. Double-glazed windows are paired panes separated by an airspace or hung in a special frame. Generally, the performance of the double-glazed window may be increased with:

- increased airspace width
- increased glass thickness
- proper use of sealings
- slightly dissimilar thicknesses of the panes
- slightly non-parallel panes

In general the airspace between the panes should not be less than 2-4 inches if an STC above 40 is desired. If this is not possible, a heavy single-glazed window can be used. The use of slightly non-parallel panes is a technique employed when extremely high sound insulation is required, such as in control rooms of television studios.

The thickness of double-glazed panes may vary from 1/8 to 1/4 inch or more per pane. Although thickness is important, the factors which most determine the noise resistance of the window is the use of sealant and the width of the airspace.

As in the case of all windows, proper sealing is extremely important. To achieve an STC above 43, double-glazed windows should be sealed permanently. If the windows must be openable, there are available special frames and sealers for openable windows which allow a maximum STC of 43.¹

Permanently sealed double-glazed windows often require an air pressure control system to maintain a constant air pressure and minimal moisture in the airspace. Without this system, the panes may defect, and, in extremely severe cases, pop out of the frames.

To further insure isolation of noise between double-glazed panes, the panes could be of different thicknesses, different weights, and slightly non-parallel to each other. This prevents acoustical coupling and resonance of sound waves.

Doors

Acoustically, doors are even weaker than windows, and more difficult to treat. Any door will reduce the insulation value of the surrounding wall. The common, hollow core wood door has an STC rating of 17 dB. Taking up about 20% of the wall, this door will reduce a 48 STC wall to 24 STC. To strengthen a door against noise, the hollow core door can be replaced by a heavier solid core wood door that is well sealed¹ and is relatively inexpensive. A solid core wood door with vinyl seal around the edges and carpeting on the floor will reduce the same 48 STC wall to only 33 dB.² An increased sound insulation value can be achieved if gasketed stops or drop bar threshold closers are installed at the bottom edge of the door. (See Figure 18)

The alternative solution to doors is to eliminate them whenever possible from the severely impacted walls and place them in more shielded walls.

In any case no mail slots or similar openings should be allowed in exterior doors.

Roofs

Acoustical treatment of roofs is not usually necessary unless the noise is extremely severe or the noise source is passing over the building. The ordinary plaster ceiling should provide adequate sound insulation except in extremely severe cases. An acoustically weak roof which is likely to require treatment is the beamed ceiling.³ Beamed ceilings may be modified by the addition of a layer of fiberglass or some other noise resistant material. Suspended ceilings are the most effective noise reducers but they are also the most expensive.

¹D.E. Bishop and P.W. Hirtle, "Notes on the Sound Transmission Loss of Residential-Type Windows and Doors," Journal of the Acoustical Society of America, 43:4 (1968).

²U.S. Gypsum, Sound Control, p. 100.

³Ibid p. 15.

Figure 18

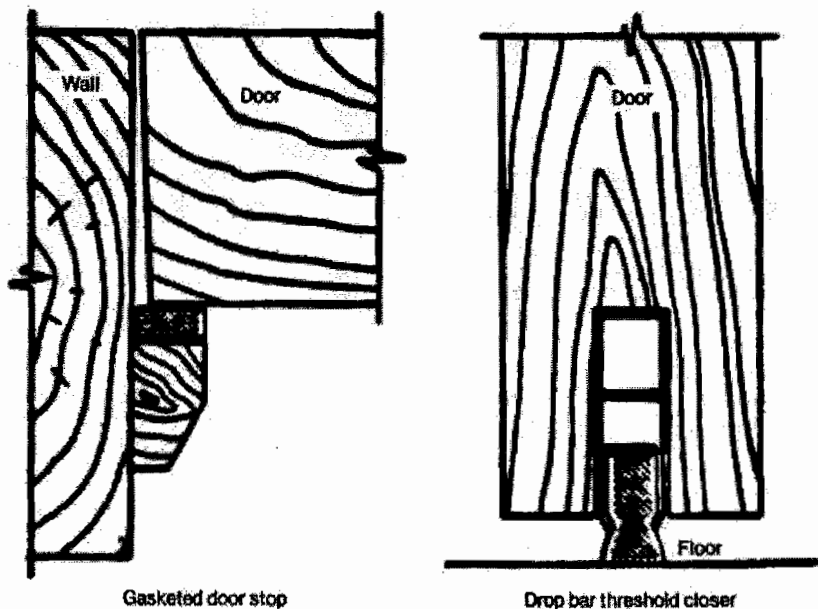

¹Ibid.

Floors

In the case of highway noise, floors would only require acoustical treatment if the highway were passing under the building. In this case, flooring would have to provide protection against structural vibrations as well as airborne sound.

Two ways to insulate a floor from noise are to install a solid concrete slab at least 6 inches thick or install a floating floor. In general, the floating floor gives the greatest amount of sound and vibration insulation; however, it is extremely expensive. Basically, a floating floor consists of a wood or concrete slab placed over the structural slab, but separated by a resilient material. The resilient material isolates the surface slab from the structural slab and the surrounding walls.

What to Look for When Reviewing Plans

The number of possible combinations of the building materials that go into walls, ceilings, windows and doors, is, no doubt, considerably short of infinite. It is however still a very large number, large enough that it would be impossible to compile a list of all the possible combinations. Therefore, do not expect to find in this section, or anywhere else for that matter, a neat table showing the STC ratings for all the types of construction you may encounter. In fact, it is not really your responsibility to determine the precise STC ratings for the walls, ceilings, windows and doors in the projects you review. Your job is simply to review the attenuation levels claimed by the sponsor/developer and determine whether or not they are reasonable.

To enable you to perform the above described task, we have prepared a list of the most common types of construction for which we have STC ratings. By comparing the type of construction proposed to one of these "model" types you should be able to tell whether the claimed STC rating is reasonable. For example, the sponsor/developer submits a description of his building stating that a 2 x 6 stud wall with standard sheathing, insulation, wood siding, and 1/2" gypsum board achieves a STC rating of 48. You look at Table 3 and find that the closest "model" wall is a 2 x 4 stud wall with wood siding, sheathing, insulation, and 1/2" gypsum board. This wall has a STC rating of 39. An 9 dB difference is quite significant considering that the walls are really quite similar. You would probably want to go back to the developer/sponsor and ask for some supporting data that proves that the 2 x 6 wall he proposes will indeed provide 48 dB of noise attenuation.

In order to make it easier to review the attenuation levels provided by the proposed construction, we suggest that you ask the developer/sponsor to complete a form such as shown in Figure 19. Such a form will give you all the information you need in a properly organized format that will facilitate your review. You could fill in the first part and simply have the developer/sponsor fill out the second part and return it with the developer certification or other project documents.

As you will recall from the previous section, most walls provide pretty good attenuation by themselves. It is the presence of windows and doors and openings such as vents that reduces the attenuation capability of the wall. Thus, after you have determined whether the basic wall itself has a reasonable STC, you must review the impact of the windows and doors. You do this by using Figure 17. First you determine the difference between the STC ratings for the wall and the windows. You enter the vertical axis of Figure 17 with that number. You read across until you intersect the line that represents the percentage of the wall taken up by the windows. Then you read down to the horizontal axis where you will find the value to be subtracted from the basic STC value of the wall. The resulting number is the combined STC value for the wall. If the wall also contains a door, repeat the same procedure, only start out with the modified STC rating for the wall. If the wall has doors only, then obviously you start with the basic wall STC rating. Finally you compare the number you have derived with that listed by the developer/sponsor. If they are fairly close, you need not pursue it further. If there is a substantial difference, you should ask for an explanation or documentation from the developer.

Once again, we caution you about borderline cases. If the attenuation required is 30 dB and the STC rating for the proposed construction is exactly 30 dB, you may want to ask the developer to provide even more attenuation. Remember that we discussed how the STC rating may overstate the actual attenuation provided by as much as 3 dB. If an additional 3 dB can be achieved at minimum cost, we would strongly urge that you seek it from the developer/sponsor.

Finally check to make sure the developer has provided some form of mechanical ventilation. If it's a single family house and a whole house fan is the means of ventilation being provided make sure that there are operable windows on walls which do not face the noise source(s) nor are perpendicular to the source(s). Otherwise the residents will have to open windows on the exposed wall, thus cancelling out much of the attenuation achieved.

Table 3
STC Ratings for Typical
Building Components¹

| Building Component | Description | STC Rating |
|--------------------|--|-------------------|
| Frame Wall | a. 5/8" x 10" Redwood Siding b. 1/2" Insulation Board Sheathing c. 2 x 4 studs 16" o.c. d. Fiberglass Building Insulation e. 1/2" Gypsum Board attached directly to studs | 39 dB |
| Stucco/Frame Wall | a. 7/8" Stucco b. No. 15 felt Building Paper and 1" Wire Mesh c. 2 x 4 Studs 16" o.c. d. Fiberglass Building Insulation e. 1/2" Gypsum Board attached directly to studs | 46 |
| Brick Veneer Wall | a. Face Brick b. 1/2" Airspace with metal ties c. 3/4" Insulation Board Sheathing d. 2 x 4 Studs 16" o.c. e. Fiberglass Building Insulation f. 1/2" Gypsum Board attached directly to studs | 56 |
| Masonry Wall | a. 1" Stucco b. 8" thick Hollow Concrete Block c. 1/2" Gypsum Board attached to furring strips | 49 (estimated) |
| Windows | Wood double hung, closed but unlocked, single glazing | 23 |
| | Aluminum sliding, latched, single glazing | 24 |
| | Wood double hung, closed but unlocked, glazed with 7/16" insulating glass | 22 |
| | Aluminum single hung, closed, glazed with 7/16" insulating glass | 25 |
| | Wood, double hung, sealed, glazed with 7/16" insulating glass with single glazed storm sash-2 1/8" separation | 35 |
| | Aluminum sliding, closed, single glazed with single glazed storm sash, 1/8" separation | 22 |
| Exterior Doors | Wood, flush solid core, with brass weather stripping | 27 |
| | Wood, flush solid core, plastic weather stripping, aluminum storm door | 34 |
| | Wood, French door, brass weather stripping | 26 |
| | Steel, flush, with urethane foam core, with magnetic weather stripping | 28 |
| Roof | Shingle Roof with attic, 1/2" gypsum wall board ceiling framed independently of roof | 43 (estimated) |

¹Except as noted, all STC ratings are from: *Acoustical and Thermal Performance of Exterior Residential Walls, Doors and Windows*, National Bureau of Standards.

**Figure 19
Description of Noise Attenuation Measures
(Acoustical Construction)**

Part I

Project Name _____

Location _____

Sponsor/Developer _____

Noise Level (From NAG) _____ Attenuation Required _____

Primary Noise Source(s) _____

Part II

1. For Walls (s) facing and parallel to the noise source(s) (or closest to parallel):

a. Description of wall construction* _____

b. STC rating for wall (rated for no windows or doors): _____

c. Description of Windows: _____

d. STC rating for window type _____

e. Description of doors _____

f. STC rating for doors _____

g. Percentage of wall (per wall, per dwelling unit) composed of
windows _____ and doors _____

h. Combined STC rating for wall component _____

2. For walls perpendicular to noise source(s):

a. Description of wall construction* _____

b. STC rating for wall (rated for no windows or doors) _____

c. Description of windows _____

d. STC rating for windows _____

e. Description of doors _____

f. STC rating for doors _____

g. Percentage of wall (per wall, per dwelling unit) composed of windows _____ and doors _____

h. Combined STC rating for wall component _____

3. Roofing component (if overhead attenuation is required due to aircraft noise):

a. Description of roof construction _____

b. STC rating (rated as if no skylights or other openings) _____

c. Description of skylights or overhead windows _____

d. STC rating for skylights or overhead windows _____

e. Percentage of roof composed of skylights or windows (per dwelling unit) _____

f. Percentage of roof composed of large uncapped openings such as chimneys _____

g. Combined STC rating for roof component _____

4. Description of type of mechanical ventilation provided _____

Prepared by _____

Date: _____

*If walls contain vents or similar openings, attach a description of duct arrangement and insulation and a statement of how much the wall STC is reduced by the presence of the vent.

Figure 19
Description of Noise Attenuation Measures
(Acoustical Construction)

Part I

Project Name PARADISE HOMES
Location ANYTOWN
Sponsor/Developer JOHN DOE + ASSOC. INC.
Noise Level (From NAG) 73 Attenuation Required 30dB
Primary Noise Source(s) HIGHWAY

Part II

1. For Walls (s) facing and parallel to the noise source(s) (or closest to parallel):
- a. Description of wall construction* 3/4" FIR PLYWOOD SIDING,
2x4 STUDS 16" O.C. 3 1/2" FIBERGLASS INSULATION
 - b. STC rating for wall (rated for no windows or doors): 37
 - c. Description of Windows: WOOD DOUBLE HUNG,
INSULATING GLASS
 - d. STC rating for window type 22
 - e. Description of doors WOOD, FLUSH, SOLID CORE
 - f. STC rating for doors 30
 - g. Percentage of wall (per wall, per dwelling unit) composed of windows 10% and doors 5%
 - h. Combined STC rating for wall component 30dB
2. For walls perpendicular to noise source(s):
- a. Description of wall construction* SAME AS ABOVE
 - b. STC rating for wall (rated for no windows or doors) 37
 - c. Description of windows SAME AS ABOVE
 - d. STC rating for windows 22
 - e. Description of doors NO DOORS

SAMPLE

- f. STC rating for doors _____
- g. Percentage of wall (per wall, per dwelling unit) composed of windows 10% and doors 0
- h. Combined STC rating for wall component 30
- 3. Roofing component (if overhead attenuation is required due to aircraft noise):
 - a. Description of roof construction N/A
 - b. STC rating (rated as if no skylights or other openings) _____
 - c. Description of skylights or overhead windows _____
 - d. STC rating for skylights or overhead windows _____
 - e. Percentage of roof composed of skylights or windows (per dwelling unit) _____
 - f. Percentage of roof composed of large uncapped openings such as chimneys _____
 - g. Combined STC rating for roof component _____
- 4. Description of type of mechanical ventilation provided CENTRAL AIR
Conditioning

Prepared by _____

Date: _____

*If walls contain vents or similar openings, attach a description of duct arrangement and insulation and a statement of how much the wall STC is reduced by the presence of the vent.

SAMPLE

Quiz on Noise Attenuation

Questions

1. What are the three basic ways to provide noise attenuation?
2. What are the responsibilities of HUD personnel regarding noise attenuation?
3. When a barrier is introduced between a source and a receiver the sound energy is redistributed along 3 indirect paths. What are these three paths?
4. What is "Path Length Difference" and how does it affect the attenuation level provided by a barrier?
5. What are "Transmission Loss Values?"
6. How does the transmission loss value of barrier material affect the attenuation capability of the barrier?
7. As a general rule, what transmission loss values should you look for?
8. If you have more than one barrier between the source and the receiver is the amount of attenuation increased substantially?
9. What are the four things to check when reviewing a proposed barrier?
10. List 3 ways to make a barrier more effective without increasing its overall height.
11. List 3 ways to make a barrier more effective without increasing its overall length.
12. What is the maximum percentage of the total area of a barrier that can be made up of openings without a significant loss in barrier effectiveness?
13. List 3 site planning techniques that are used to shield residential developments.
14. When are parks and playgrounds not noise compatible uses that can be employed as buffers?
15. What are the two main things to look for when reviewing site plan changes?
16. What are some of the building orientations which can aggravate noise problems?
17. What is the Sound Transmission Class (STC) rating?
18. Which is better a high STC or a low STC rating?
19. What kinds of conditions were STC ratings originally developed for?
20. What should you do when using STC ratings in a transportation noise situation?
21. List 5 ways to improve the attenuation capability of a wall.
22. Windows are one of the acoustically weakest components in a wall. List 3 ways to reduce the negative effects of windows.
23. What is the best way to reduce the effect of doors?

Quiz on Noise Attenuation

Answers

1. a. barriers or berms
b. site design
c. acoustical construction
2. a. to make sure the project sponsor/developer is aware of the attenuation requirements
b. provide sponsor/developer with an overview of available options
c. review attenuation proposals to make sure they are adequate
3. a. A diffracted path over the top of the barrier
b. A transmitted path through the barrier
c. A reflected path away from the receiver
4. "Path Length Difference" is the difference in distance that sound must travel diffracting over the barrier rather than passing directly through it. Since sound energy decreases over distance, the greater the path length distance the greater the attenuation.
5. "Transmission Loss Values" represent the amount noise levels will be reduced when the sound waves pass through a barrier.
6. Since the attenuation provided by a barrier is a function of both the sound energy that goes over the top and the energy that goes through the barrier, if the transmission loss value is low then the effectiveness of the barrier will be greatly reduced.
7. If the transmission loss value of the barrier material is at least 10dB greater than the attenuation level provided by diffraction (i.e. barrier height) there shouldn't be any problem.
8. No. The combined effect of multiple barriers does not normally provide significantly greater attenuation than a single barrier. For design purposes, the general procedure is to assume the attenuation of the most effective barrier.
9. a. Is it high enough?
b. Is it long enough?
c. Is it made of the right material?
d. Is it properly constructed?
10. a. move the barrier closer to the source
b. bend the top of the barrier towards the source
c. do both
11. a. move it closer to the receiver
b. bend the ends toward the receiver
c. do both
12. 1 percent
13. Any 3 of the below:
a. increasing the distance between the source and the receiver
b. placing noise compatible land uses between the source and the receiver
c. locating barrier type buildings parallel to the source
d. orienting residences away from the noise
14. when they are the only ones associated with the project
15. a. is the separation between the source and receiver great enough
b. if a noise compatible building is being used as a barrier is it tall and long enough?
16. Building orientations which trap noise and cause it to reverberate off building walls. This would include shapes where a court is open to the source or where a series of buildings are arranged perpendicular to the source.
17. The STC rating is equal to the number of decibels a sound is reduced as it passes through a material.
18. A high STC rating is better.
19. The STC ratings were originally intended primarily for use with interior partitions and for noise such as speech, radios, television.
20. Recognize that the STC rating may overstate the effectiveness of the materials by 2-3db.
21. Any of the 9 below:
a. increase the mass and stiffness of the wall
b. use cavity partitions
c. increase the width of the airspace
d. increase the spacing between studs
e. use staggered studs
f. use resilient materials to hold the studs and finish materials together
g. use of dissimilar layers (leaves)
h. add acoustical blankets
i. seal cracks and edges
22. Any of the 4 below:
a. close the windows and provide mechanical ventilation
b. reduce window size
c. increase glass thickness
d. install double glazed windows
23. Eliminate them from severely impacted walls

Chapter 5
Noise Assessment
Guidelines



U.S. Department of Housing and Urban Development
Office of Policy Development and Research

Noise Assessment
Guidelines

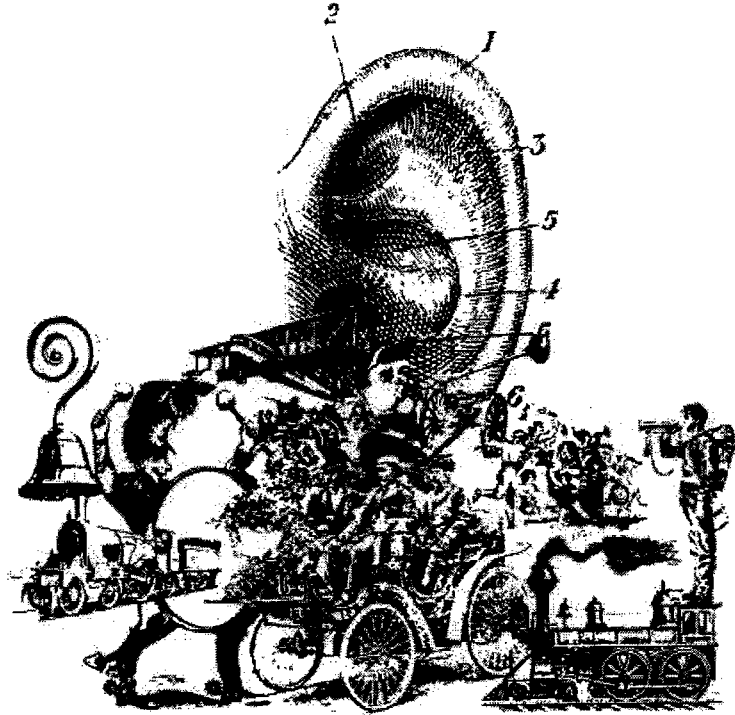

Noise Assessment Guidelines

Foreword

In choosing among alternative sites for housing, potential noise problems are prominent among the issues that must be examined. These Noise Assessment Guidelines were developed to provide HUD field staff, interested builders, developers, and local officials with an easy-to-use method of evaluating noise problems with a minimum of time and effort.

We believe that this set of tools will simplify the process of balancing the goal of environmental protection with those of efficiency and reduced housing costs. We hope you will find them useful, and invite your comments.

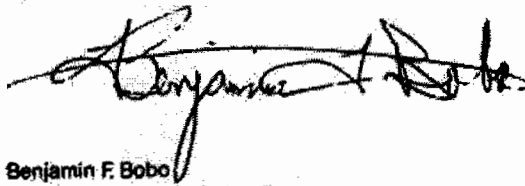

Benjamin F. Bobo
Acting Assistant Secretary for
Policy Development and Research

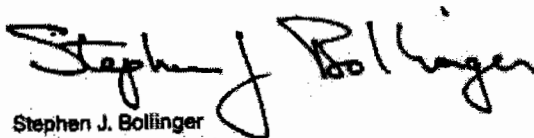

Stephen J. Bollinger
Assistant Secretary for
Community Planning and
Development

Preface

The Department of Housing and Urban Development, in its efforts to provide decent housing and a suitable living environment, is concerned with noise as a major source of environmental pollution and has issued Subpart B on Noise Abatement and Control to Part 51 of Title 24 of the Code of Federal Regulations.

The policy established by Subpart B embodies HUD objectives to make the assessment of the suitability of the noise environment at a site: (1) easy to perform; (2) uniformly applicable to different noise sources; and (3) as consistent as possible with the assessment policies of other Federal departments and agencies. In furtherance of these objectives, the Office of Policy Development and Research has sponsored research to provide site analysis techniques. These *Noise Assessment Guidelines* do not constitute established policy of the Department but do provide a methodology whose use is encouraged by HUD as being consistent with its objectives. The *Guidelines* provide a means for assessing separately the noise produced by airport, highway, and railroad operations, as well as the means for aggregating their combined effect on the overall noise environment at a site.

This booklet has been prepared by Bolt Beranek and Newman Inc., under Contract No. H-2243R for the U.S. Department of Housing and Urban Development. It is a revision of an earlier edition published in August 1971. With the exception of changes made by the Department, the contractor is solely responsible for the accuracy and completeness of the data and information contained herein.

Contents

| | |
|-----|---|
| III | Foreword |
| IV | Preface |
| 2 | Introduction |
| 3 | Combining Sound Levels in Decibels |
| 4 | Aircraft |
| 4 | Necessary Information |
| 4 | Evaluation of Site Exposure to Aircraft Noise |
| 6 | Roadways |
| 6 | Necessary Information |
| 6 | Evaluation of Site Exposure to Roadway Noise |
| 6 | Automobile Traffic |
| 7 | Adjustments for Automobile Traffic |
| 8 | Truck Traffic |
| 8 | Adjustments for Heavy Trucks |
| 9 | Attenuation of Noise by Barriers |
| 10 | Steps to Evaluate a Barrier |
| 14 | Railways |
| 14 | Necessary Information |
| 14 | Evaluation of Site Exposure to Railway Noise |
| 14 | Diesel Locomotives |
| 14 | Adjustments for Diesel Locomotives |
| 15 | Railway Cars and Rapid Transit Systems |
| 15 | Adjustments for Railway Cars and Rapid Transit Trains |
| 17 | References |
| 18 | Summary of Adjustment Factors |

Introduction

These guidelines are presented as part of a continuing effort by the Department of Housing and Urban Development to provide decent housing and a suitable living environment for all Americans.

The procedures described here have been developed so that people without technical training will be able to assess the exposure of a housing site to present and future noise conditions. In this context, the site may hold only one small building, in which case the noise assessment is straightforward. Larger sites may hold larger buildings, or many buildings, and the noise level may be different at different parts of the site (or building). Assessments of the noise exposure should be made at representative locations around the site where significant noise is expected. These are designated as "Noise Assessment Locations," abbreviated NAL in the following text.

The only materials required are a map of the area, a ruler (straight edge), a protractor and a pencil. Worksheets and working figures are provided separately.

All of the information you need can be easily obtained – usually by telephone. For convenience, this information is listed at the beginning of each section under headings that indicate the most likely source. While you are obtaining this information, be sure to ask about any approved plans for future changes that may affect noise levels at the site – for example: land-use changes, changes in airport runway traffic, widening of roads, and so forth. In all evaluations, you

should assess the condition that will have the most severe or most lasting effect on the use of the site.

Wherever possible, you should try to assess noise environments expected at least ten years in the future.

The degree of acceptability of the noise environment at a site is determined by the outdoor day-night average sound level (DNL) in decibels (dB). The assessment of site acceptability is presented first as an evaluation of the site's exposure to three major sources of noise – aircraft, roadways, and railways. These are then combined to assess the total noise at a site. Worksheets are provided at the back of these Guidelines to use in summarizing your evaluations.

The noise environment at a site will come under one of three categories:

Acceptable (DNL not exceeding 65 decibels) The noise exposure may be of some concern but common building constructions will make the indoor environment acceptable and the outdoor environment will be reasonably pleasant for recreation and play.

Normally Unacceptable (DNL above 65 but not exceeding 75 decibels) The noise exposure is significantly more severe; barriers may be necessary between the site and prominent noise sources to make the outdoor environment acceptable; special building constructions may be necessary to ensure that people indoors are sufficiently protected from outdoor noise.

Unacceptable (DNL above 75 decibels) The noise exposure at the site is so severe that the construction cost to make the indoor

noise environment acceptable may be prohibitive and the outdoor environment would still be unacceptable.

When measuring the distance from the site to any noise source, measure from the source to the nearest points on the site where buildings having noise-sensitive uses are located. These points define the Noise Assessment Locations for the site. The relevant measurement location for buildings is a point 2 meters (6.5 feet) from the facade.

If at any point during the assessment the site's exposure to noise is found to be Unacceptable or Normally Unacceptable, every effort should be made to improve the condition, e.g., the location of the proposed dwellings can be changed or some shielding can be provided to block the noise from that source.

Where quiet outdoor space is desired at a site, distances should be measured from the important noise sources to the outdoor area in question and the combined noise exposure should be assessed.

Frequently, the locations of dwellings have not yet been specified at the time the noise assessment of a site is made. In these instances, distances used in the noise assessment should be measured as 2 meters less than the distance from the building setback line to the major sources of noise.

Combining Sound Levels in Decibels

The noise environment at a site is determined by combining the contributions of different noise sources. In these Guidelines, Workcharts are provided to estimate the contribution of aircraft, automobile, truck, and train noise to the total day-night average sound level (DNL) at a site. The DNL contributions from each source are expressed in decibels and entered on Worksheet A. The combined DNL from all the sources is the DNL for the site and is the value used to determine the acceptability of the noise environment.

Sound levels in decibels are *not* combined by simple addition! The following table shows how to combine sound levels:

Table

| Difference in Sound Level | Add to Larger Level |
|---------------------------|---------------------|
| 0 | 3.0 |
| 1 | 2.5 |
| 2 | 2.1 |
| 3 | 1.8 |
| 4 | 1.5 |
| 5 | 1.2 |
| 6 | 1.0 |
| 7 | 0.8 |
| 8 | 0.6 |
| 9 | 0.5 |
| 10 | 0.4 |
| 12 | 0.3 |
| 14 | 0.2 |
| 16 | 0.1 |
| greater than 16 | 0 |

Use the table by first finding the numerical difference in sound level between two levels being combined. Entering the table with this value, find the value to be added to the larger of the two levels, add this value to the larger level to determine the total. Where more than two levels are to be combined, use the same procedure to combine any two levels; then use this subtotal and combine it with any other level, and so on. Fractional numerical values may be interpolated from the table; however, the final result should be rounded to the nearest whole number.

Example 1: In performing a site evaluation, the separate DNL values for airports, road traffic, and railroads have been listed on Worksheet A as 58, 63, and 61 decibels. In order to complete the final evaluation of the site, these separate DNL values must be combined. The difference between 63 and 58 is 5; from the table you find that 1.8 should be added to 63, for a subtotal of 64.8. The difference between 64.8 and 61 is 3.8; from the table you interpolate that approximately 1.9 should be added to 64.8 for a total of 66.7 or 67 dB when rounded to whole numbers. This example shows how noise from different sources may be Acceptable, individually, at a site, but when combined, the total noise environment may exceed the Acceptable DNL limit of 65 decibels.

Aircraft

Necessary Information

To evaluate a site's exposure to aircraft noise, you will need to consider all airports (civil and military) within 15 miles of the site. The information required for this evaluation is listed below under headings that indicate the most likely source. Before beginning the evaluation, you should record the following information on Worksheet B:

From the FAA Area Office or the Military Agency in charge of the airport:

- Are current DNL or NEF (Noise Exposure Forecast) contours available? Noise contours are available for almost all military airports. These contours have been developed and published as part of the Air Installation Compatible Use Zone (AICUZ) program of the Department of Defense. The contours are published normally as part of an AICUZ report. Noise contours are also available for many civil airports. When available, they are superimposed on a map with an appropriately marked scale (see Figure 1, page 4).
- Any available information about approved plans for runway changes (extensions or new runways).

From the FAA Control Tower or Airport Operations (if DNL or NEF contours are not available):

- The number of nighttime jet operations (10 p.m. - 7 a.m.)
- The number of daytime jet operations (7 a.m. - 10 p.m.)
- The flight paths of the major runways.
- Any available information about expected changes in airport traffic, e.g., will the number of operations increase or decrease in the next 10 or 15 years.

In making your evaluation, use the data for the heaviest air traffic condition, whether present or future.

Evaluation of Site Exposure to Aircraft Noise

If current DNL (or NEF) contours are available (as in Figure 1 page 4), locate the site on the map by referring to the marked distance scale. If there are no other noise sources in the area, you do not need to do anything else. If there are other noise sources affecting the site, you will need to find the precise DNL value so you can combine it with the other sources. Obtain the DNL at the appropriate NAL on the site by interpolation between the

contours on either side of the NAL. If NEF contours are used, estimate DNL by adding 35 decibels to the NEF values. Note that contours are usually provided in 5 decibel increments. (See Example 2 on page 4.) When supersonic aircraft operations are present, DNL contours are required for the assessment.

If DNL or NEF contours are not available, the DNL at a site may be estimated in several different ways:

- An FAA Handbook (Reference 1) can be used to estimate DNL contours for sites in general aviation airport vicinities. General aviation airports exclude commercial jet transports but may include business jets.
- A handbook available from EPA (Reference 2 at the back of this Guide) can be used to calculate DNL at individual points.
- A procedure for constructing approximate DNL contours for sites near commercial jet

Figure 1
Example of DNL Contours

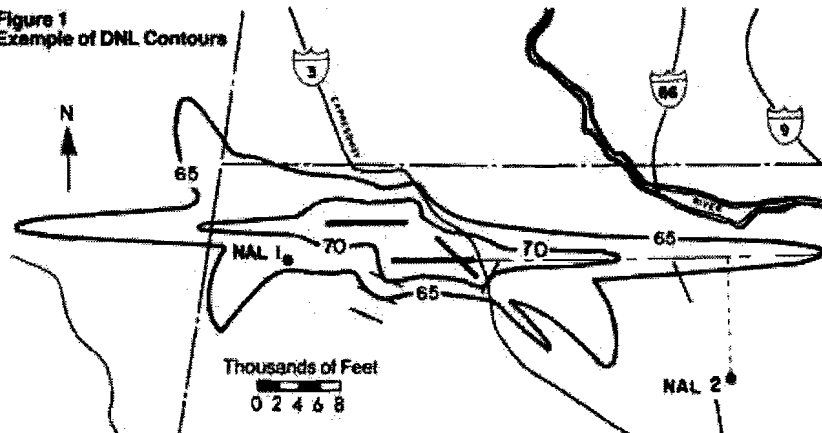

Example 2: The illustration in Figure 1 at the top of page 4 shows the NAL's on a map that has DNL contours. We find that NAL number 1 lies between the 65 and 70 dB contours and that NAL number 2 lies outside the 65 dB contour.

We find the DNL at NAL number 1 by interpolation from the distances between the NAL and the 65 and 70 dB contours.

By scaling off the map, we find that the distance from the NAL, measured perpendicularly to the contours, is 800 feet to the 65 dB contour and 2400 feet to the 70 dB contour. The distance between the 65 and 70 dB contours is $2400 + 800 = 3200$ feet. We find the DNL at the NAL number 1 to be 65 decibels plus $800/3200 \times 5$ decibels = 66.3 decibels.

Example 3: The illustration in Figure 2 at the bottom of page 5 shows an airport for which DNL or NEF contours are not available. The airport has 10 nighttime and 125 daytime jet operations.

To construct the approximate contours, we determine the effective number of operations as follows:

$$10 (\text{nighttime}) \times 10 = 100$$

Add to this the actual number of daytime operations:

$$100 + 125 (\text{daytime}) = 225$$

To determine the distances A and B in relation to the runway (see Figure 3, page 5), enter the effective number of operations on the horizontal scales of the charts in Figure 3;

airports without supersonic aircraft is as follows:

Determine the "effective" number of jet operations at the airport by first multiplying the number of nighttime jet operations by 10.

Then add the number of daytime jet operations to obtain an effective total (see Example 3, page 4).

On a map of the area showing the principal runways, mark the location of the site and, using the diagram and charts of Figure 3 on page 5, construct approximate DNL contours of 65, 70, and 75 dB for the major runways and flight paths most likely to affect the site. (see Figure 2, page 5.)

Although a site may be Acceptable for exposure to aircraft noise; exposure to other sources of noise, when combined with the aircraft noise, may make the site Unacceptable. Therefore, if necessary, values of aircraft noise exposure less than 65 dB can be estimated from Table 2. Scale the shortest

distance D^2 from the NAL to the flight path, as in Figure 2. Scale the distance D^1 from the 65 dB contour to the flight path. Divide D^2 by D^1 and enter this value into the following table to find the approximate DNL at the NAL.

| D^2/D^1 | DNL dB |
|-----------|--------|
| 1.00 | 65 |
| 1.12 | 64 |
| 1.26 | 63 |
| 1.41 | 62 |
| 1.58 | 61 |
| 1.78 | 60 |
| 2.00 | 59 |
| 2.24 | 58 |
| 2.51 | 57 |
| 2.82 | 56 |
| 3.16 | 55 |

Figure 3
Charts for Estimating
DNL for Aircraft Operations

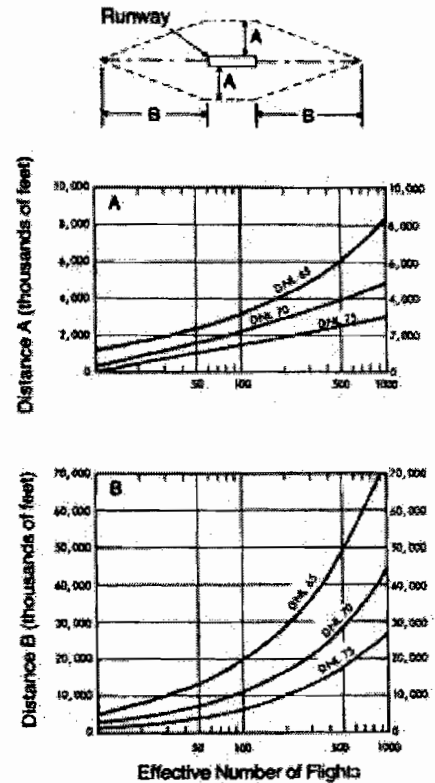
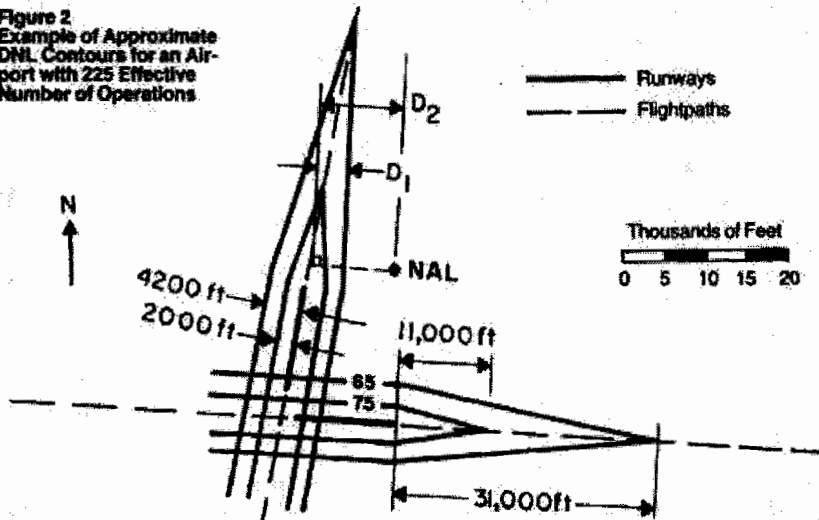

Figure 2
Example of Approximate
DNL Contours for an Airport
with 225 Effective
Number of Operations



read up to the DNL curves; read across the chart to the left to obtain distances A and B from the vertical scales on the charts.

We find from Figure 3, for example, that for 225 effective operations, distance A is 4200 feet for the 65 dB contour and 2000 feet for the 75 dB contour. Distance B is 31,000 feet for the 65 dB contour and 11,000 feet for the 75 dB contour.

Example 4a: The NAL shown in Figure 2 is outside the 65 dB contour. The distance D^2 from the NAL to the flight path is 9700 feet. The distance D^1 from the 65 dB contour to the flight path, measured perpendicularly from the contour, is 3700 feet. The ratio D^2/D^1 is $9700/3700 = 2.62$. From Table 2 we find the DNL from the airport to be 56.6 dB. We do not know whether the site is Acceptable or not, however, since we must also assess the contribution of roadway and train noise to the total DNL at the site.

Example 4b: We observe that the perpendicular distance (D^2) from NAL number 2 (Figure 1) to the flight path is more than 3 times the distance (D^1) from the 65 dB contour to the flight path. From Table 2 we find that the contribution of the airport to the DNL at NAL number 2 is less than 55 decibels. We need not consider the airport further in accessing the noise environment at this site.

Roadways

Necessary Information

To evaluate a site's exposure to roadway noise, you will need to consider all roads that might contribute to the site's noise environment; roads farther away than 1000 feet normally may be ignored.

Before beginning the evaluation, determine if roadway noise predictions already exist for roads near the site. Also try to obtain all available information about approved plans for roadway changes (e.g., widening existing roads or building new roads) and about expected changes in road traffic (e.g., will the traffic on this road increase or decrease in the next 10 to 15 years).

If noise predictions have been made, they should be available from the City (County) Highway or Transportation Department. If not, record the following information on page 1 of Worksheet C:

- The distances from the NAL's for the site to the near edge of the nearest lane and the far edge of the farthest lane for each road.
- Distance to stop signs.
- Road gradient, if 2 percent or greater.
- Average speed.
- The total number of automobiles for both directions during an average 24-hour day. Traffic engineers refer to this as ADT, Average Daily Traffic (or sometimes AADT, meaning Annual Average Daily Traffic).
- The number of trucks during an average 24-hour day in each direction.

If possible, separate trucks into "heavy trucks" – those weighing more than 26,000 pounds with three or more axles – and "medium trucks" – those between 10,000 and 26,000 pounds. (Each medium truck is counted as equal to 10 automobiles.) Trucks under 10,000 pounds are counted as automobiles. Count buses capable of carrying more than 15 seated passengers as "heavy" trucks – others, as "medium" trucks. If it is

not possible to separate the trucks into those that are heavy and those that are not, treat all trucks as though they are "heavy."

Note: If the road has a gradient of 2 percent or more, record the numbers for uphill and downhill traffic separately since these figures will be needed later; otherwise, simply record the total number of trucks. Most often you will have to assume that the uphill and downhill traffic are equally split.

- The fraction of ADT that occurs during nighttime (10 p.m. to 7 a.m.). If this is unknown, assume 0.15 for both trucks and autos.

Evaluation of Site Exposure to Roadway Noise

Traffic surveys show that the amount of roadway noise depends on the percentage of trucks in the total traffic volume. To account for this effect, you must evaluate automobile and truck traffic separately and then combine the results.

The noise environment at each site due to traffic noise is determined by utilizing a series of Workcharts to define the contribution of automobiles and trucks from one or more roads at that site. Each noise source yields a separate DNL value.

Workchart 1 provides a graph for assessing a site with respect to the noise from automobiles, light and medium trucks; Workchart 2 provides a similar graph for assessment of heavy truck noise. These values are combined for each road affecting the noise environment at the site to obtain the total contribution of roadway noise. Remember, the noise from aircraft and railways must also be considered before determining the suitability of this site's noise environment.

Effective Distance

Before proceeding with these separate eval-

uations, however, determine the "effective distance" to each road from the dwelling or outdoor residential activity (the NAL's for the site) by averaging the distances to the nearest edge of the nearest lane and to the farthest edge of the farthest lane of traffic. (See Example 5, page 8, and Figure 4, page 7.) **Note:** For roads with the same number of lanes in both directions, the effective distance is the distance to the center of the roadway (or median strip, if present).

Automobile Traffic

Workchart 1 was derived with the following assumptions:

- There is line-of-sight exposure from the site to the road; i.e., there is no barrier which effectively shields the site from the noise of the road.
- There is no stop sign within 500 feet of the site; traffic lights do not count because there is usually traffic moving on one street or the other.
- The average automobile traffic speed is 55 mph.
- The nighttime portion of ADT is 0.15.

If each road meets these four conditions, proceed to Workchart 1 for the evaluation. Enter the horizontal axis with the effective distance from the roadway to the NAL; draw a vertical line upward from this point. Enter the vertical axis with the effective automobile ADT; draw a horizontal line across from this point. (The "effective" automobile ADT is the sum of automobiles, light trucks, and 10 times the number of medium trucks in a 24-hour day.) Read the DNL value from Workchart 1 where the vertical and horizontal lines intersect. Record this value in column 16, Worksheet C.

But:

If any of the four conditions is different, make

Example 5: The site shown in Figure 4 is exposed to noise from three major roads: Road No. 1 has four lanes, each 12 feet wide, and a 30-foot wide median strip which accommodates a railroad track. Road No. 2 has four lanes, each 12 feet wide. Road No. 3 has six lanes, each 15 feet wide, and a median strip 30 feet wide.

The distance from NAL No. 1 to the near edge of Road No. 1 is 300 feet. The distance

to the far edge of Road No. 1 is 300 feet, plus the number of lanes times the lane width, plus the width of the median strip. Thus, the distance to the farthest edge of the road is:

$$300 + (4 \times 12) = 378 \text{ ft}$$

The effective distance is

$$\frac{378 + 300}{2} = 339 \text{ ft}$$

This is the value to be entered on line 1c of Worksheet C. The effective distances from the appropriate NAL's to Road No. 2 and Road No. 3 are found by the same method.

The distances shown in Figure 4 will be used for all roadway examples in this booklet.

Figure 4
Plan View of Site showing How Distances Should Be Measured from the Noise Assessment Location (NAL) of the Dwelling Nearest to the Source

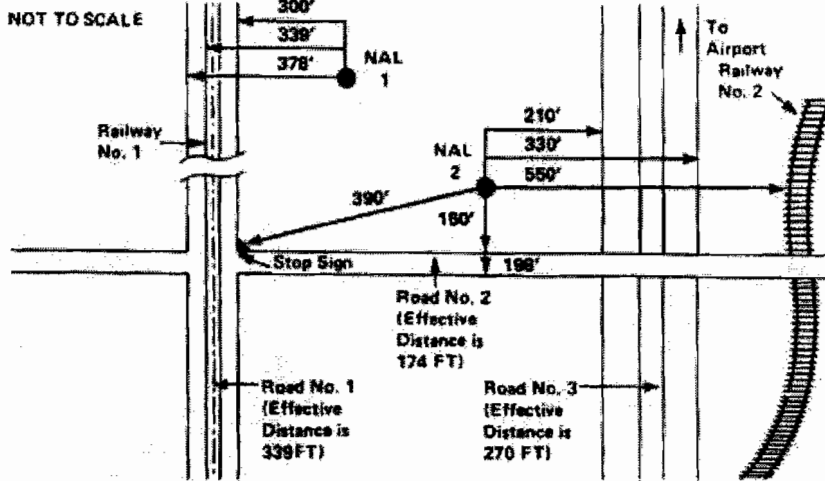

the necessary adjustments (on page 2, Worksheet C) listed below and then use Workchart 1 for the final evaluation.

First, a few general words about adjustments as they are applied in these Guidelines. Each Workchart has been derived for a baseline condition which is often found in practical cases. Where conditions differ from the baseline, they are accounted for by a series of one or more adjustment factors.

The adjustment factors are used as multipliers times the average number of vehicles operating during a 24-hour day. If more than one adjustment is required, it is not necessary that each be multiplied times the basic traffic flow separately; all adjustment factors are multiplied together, and then multiplied times the original traffic flow data. This will become clearer as you examine the Worksheets at the back of these Guidelines and

Figure 5
Use of Workchart 1 To Evaluate Automobile Traffic Noise

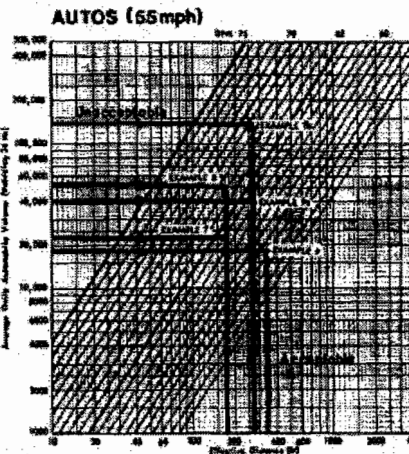

Example 6: Road No. 1 meets the four conditions that allow for an immediate evaluation. In obtaining the information necessary for this evaluation, it was found that the automobile ADT is 18,000 vehicles (Line 5c of Worksheet C). On Workchart 1 we locate on the vertical scale the point representing 18,000 and on the horizontal scale the point representing 339 feet (see Figure 5). (Note that we must estimate the location of this point.) Using a straight-edge we draw lines to connect these two values and find that the NAL exposure to automobile noise from this road is a DNL of 58 dB, as read from the scale at the top of the graph.

Example 7: Road No. 2 has a stop sign at 390 feet from NAL No. 2. The automobile ADT is reported as being 32,500 vehicles (line 5c of Worksheet C). From Table 3 we interpolate between 300 and 400 feet to find the adjustment factor for stop-and-go traffic to be 0.69. The adjusted traffic ADT is

$0.69 \times 32,500 = 22,425$ vehicles per day
and with an effective distance of 174 feet from NAL No. 2, we find from Workchart 1 that the approximate value of DNL is 64 dB.

work through the examples. After you have become familiar with the Guidelines, you will be able to work examples directly from the worksheets without referring back to the text. To simplify your work, all the adjustment factors are summarized at the back of these Guidelines.

Adjustments for Automobile Traffic

Stop-and-Go Traffic:

If there is a stop sign (not a traffic signal) within 600 feet of the NAL so that the flow of traffic is completely interrupted on the road under consideration, find the stop-and-go adjustment factor for automobiles from Table 3. Enter this value in column 9 on Worksheet C.

Table 3

| Distance from NAL to Stop Sign in Feet | Automobile Stop-and-Go Adjustment Factor |
|--|--|
| 0 | 0.10 |
| 100 | 0.25 |
| 200 | 0.40 |
| 300 | 0.55 |
| 400 | 0.70 |
| 500 | 0.85 |
| 600 | 1.00 |

Average Traffic Speed:

If the average automobile speed is other than 55 mph, enter the appropriate adjustment from Table 4 in column 10 of Worksheet C.

Table 4

| Average Traffic Speed | Auto Speed Adjustment Factor |
|-----------------------|------------------------------|
| 20 (mph) | 0.13 |
| 25 | 0.21 |
| 30 | 0.30 |
| 35 | 0.40 |
| 40 | 0.53 |
| 45 | 0.67 |
| 50 | 0.83 |
| 55 | 1.00 |
| 60 | 1.19 |
| 65 | 1.40 |
| 70 | 1.62 |

Example 8: Suppose that the stop sign on Road No. 2 were replaced by a traffic signal for which no stop-and-go adjustment is made and that the ADT increases to 75,000 vehicles. In addition, assume that the average speed is 45 mph instead of 55 mph. You adjust the new automobile ADT of 75,000 vehicles by the Auto Speed Adjustment Factor from Table 4

$0.67 \times 75,000 = 50,250$ vehicles
and at an effective distance of 174 feet find from Workchart 1 that the approximate value of DNL is 67 dB.

Nighttime Adjustment

DNL values are affected by the proportion of traffic volume that occurs during "daytime" (7 a.m. to 10 p.m.) and "nighttime" (10 p.m. to 7 a.m.). The graph on Workchart 1 assumes that 15 percent of the total ADT occurs during nighttime. If a different proportion of the traffic occurs at night, find the appropriate nighttime adjustment factor from Table 5. Record your answer in column 11 of Worksheet C.

Table 5

| Nighttime Fraction of ADT | Nighttime Adjustment Factor |
|---------------------------|-----------------------------|
| 0 | 0.43 |
| 0.01 | 0.48 |
| 0.02 | 0.50 |
| 0.05 | 0.62 |
| 0.10 | 0.81 |
| 0.15 | 1.00 |
| 0.20 | 1.19 |
| 0.25 | 1.38 |
| 0.30 | 1.57 |
| 0.35 | 1.77 |
| 0.40 | 1.96 |
| 0.45 | 2.15 |
| 0.50 | 2.34 |

Once you have selected all the appropriate adjustment factors and entered them on page 2 of Worksheet C, multiply all the factors together, then multiply by the automobile ADT (column 12) for 24 hours, found on page 1 of Worksheet C. The resulting adjusted ADT should be entered in column 13. This is the ADT value to be used, in conjunction with the effective distance from the NAL to the road, to find the DNL value from Workchart 1. Enter this DNL value in column 14 of Worksheet C. Remember this is the DNL from automobile (as well as light and medium truck) noise; you must still find the DNL contribution from heavy truck noise in order to obtain the total DNL produced by the roadway you are assessing.

Example 9a: Road No. 3 is a limited access highway with no stop signs and the average speed is 55 mph. Current traffic data indicate an automobile ADT of 40,000 vehicles of which 15 percent occurs during nighttime hours (10 p.m. to 7 a.m.). With an effective distance of 270 feet to NAL No. 2, Workchart 1 is used to show that the DNL for existing automobile traffic is between 63 and 64 dB. Round off to 64 dB.

Attenuation of Noise by Barriers:

This adjustment reduces the noise produced by automobiles and trucks on the same road. Instructions for this adjustment appear after the noise assessment for truck traffic below.

Truck Traffic

Whenever possible, separate the average daily volume of trucks into heavy trucks (more than 26,000 pounds vehicle weight and three or more axles); medium trucks (less than 26,000 pounds but greater than 10,000 pounds), light trucks (counted as if they are automobiles). You should already have accounted for medium and light trucks in your automobile evaluation. Do not forget that buses that can carry more than 15 seated passengers are counted as heavy trucks. Heavy trucks (including buses) must be analyzed separately because they have quite different noise characteristics. If it is not possible to separate the trucks into those that are heavy and those that are not, treat all trucks as though they are "heavy."

Workchart 2, which is used to evaluate the site's exposure to heavy truck noise, was derived with the following assumptions:

- There is line-of-sight exposure from the site to the road; i.e., there is no barrier which effectively shields the site from the road noise.
- The road gradient is less than 2 percent.
- There is no stop sign (traffic signals are permissible) within 600 feet of the site.
- The average truck traffic speed is 55 mph.
- The nighttime fraction of ADT is 0.15.

If the road meets these five conditions, proceed to Workchart 2 for an immediate evaluation of the site's exposure to heavy truck noise from that road.

But:

If any of the conditions is different, make the

necessary adjustment(s) listed below and then use Workchart 2 for the evaluation.

Figure 6.
Use of Workchart 2 to
Evaluate Heavy Truck Noise
Heavy Trucks (55 mph)

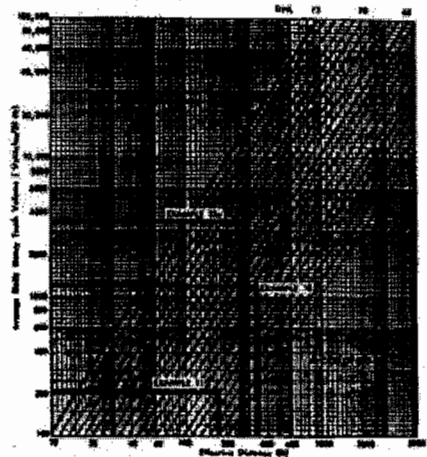

Adjustments for Heavy Trucks

Road Gradient:

If there is a gradient of 2 percent or more, find the appropriate adjustment factor, for heavy trucks going uphill only, as shown in Table 6. List this factor in column 17 of Worksheet C.

Table 6

| Percent of Gradient | Adjustment Factor |
|---------------------|-------------------|
| 2 | 1.4 |
| 3 | 1.7 |
| 4 | 2.0 |
| 5 | 2.3 |
| 6 or more | 2.5 |

Example 9b: However, traffic projections estimate that in 10 years the ADT will increase to 100,000 vehicles at an average speed of 55 mph and nighttime usage will increase to 25 percent. For future traffic, you must adjust the future ADT of 100,000 for the effect of increased nighttime use. From Table 5, you find an adjustment factor of 1.38. The adjusted ADT is

$$1.38 \times 100,000 = 138,000$$

and at an effective distance of 270 feet you find from Workchart 1 that the DNL will increase to 69 dB; therefore, provision for extra noise control measures should be explored. We will examine in Example 13 the effect of terrain as a shielding barrier that provides sound attenuation.

Example 10: Road No. 1 on Figure 4 meets the four conditions that allow for an immediate evaluation. The ADT for heavy truck flow is 1200 vehicles. Workchart 2 shows that the exposure to truck noise from this road at an effective distance of 339 feet is a DNL of 63 dB at NAL No. 1.

Average Traffic Speed:

Make this adjustment if the average speed differs from 55 mph. If the average truck speed differs with direction, treat the uphill and downhill traffic separately. Select the appropriate adjustment factors from Table 7 below, entering them in column 18 of Worksheet C.

Table 7

| Average Traffic Speed MPH | Heavy Truck Speed Adjustment Factor |
|---------------------------|-------------------------------------|
| 50 or less | 0.81 |
| 55 | 1.00 |
| 60 | 1.17 |
| 65 | 1.38 |

Once you have found the speed adjustment factor, you can combine the uphill and downhill traffic. For uphill traffic, multiply the gradient factor times the speed adjustment factor times uphill traffic volume (truck ADT column 19) (assuming one-half the total 24-hour average number of trucks unless specific information to the contrary exists), entering the product in column 20. Multiply the speed adjustment factor for downhill traffic times the downhill traffic volume (truck ADT/2 column 19). Add the values for uphill and downhill traffic, entering this sum in column 21. You may now complete the assessment of heavy truck noise without regard to uphill and downhill traffic separation.

Stop-and-Go Traffic:

If there is a stop sign (remember, not a traffic signal) within 600 feet of an NAL for the site on the road being assessed, find the adjustment factor determined according to Table 8. Enter it in Column 22 of Worksheet C.

Example 11: Road No. 2 has a stop sign at 390 feet from NAL No. 2. There is also a road gradient of 4 percent. No heavy trucks are allowed on this road, but a schedule shows an average of 12 large buses pass along the road per hour between 7 a.m. and 10 p.m., although no buses are scheduled during the remaining nighttime period. The buses are equally divided in each direction along the road. (Remember large buses, those that carry over 15 seated passengers, count as heavy trucks.)

We find the ADT for the "heavy trucks" (the buses in this case) by multiplying the average number of vehicles per hour by the number of hours between 7 a.m. and 10 p.m. That is, $12 \times 15 = 180$, or 90 vehicles in each direction. We find from Table 6 that the gradient adjust-

Table 8

| Heavy Truck Traffic Volume per Day | Heavy Truck Stop-and-Go Adjustment Factor |
|------------------------------------|---|
| Less than 1200 | 1.8 |
| 1201 to 2400 | 2.0 |
| 2401 to 4800 | 2.3 |
| 4801 to 9600 | 2.8 |
| 9601 to 19,200 | 3.8 |
| More than 19,200 | 4.5 |

Nighttime Adjustment

After all the above adjustments are made, do not forget to adjust for nighttime operations if they are not 15 percent of the total ADT, using the factors obtained from Table 5 just as for automobiles. Enter this value in column 23 of Worksheet C.

At this point, multiply the adjustment factors for nighttime and stop-and-go traffic times the heavy truck traffic volume in column 21 to find the adjusted heavy truck ADT, entering the product in column 24. Use this value and the effective distance from the NAL to the road to find the truck DNL from Workchart 2, entering your answer in column 25 of Worksheet C. If no shielding barriers are to be considered, combine the DNL from heavy trucks with the DNL from automobiles (column 14). The result is the DNL from the road being assessed and should be entered on Worksheet C.

But:

If a shielding barrier is to be considered for the site, make the analysis described below separately for automobiles and then for heavy trucks before combining the DNL values. This step is necessary since barriers are far more effective for automobiles than for heavy trucks. Once you have found the amount of attenuation provided by the barrier for automobiles, enter it in column 15. Find the value of barrier attenuation for heavy

ment factor for uphill traffic is 2.0. We find the truck volume adjusted for gradient is

$$\begin{aligned} \text{uphill:} & 90 \times 2.0 = 180 \\ \text{downhill:} & = 90 \\ \text{total (column 21)} & = 270 \text{ vehicles} \end{aligned}$$

From Table 8, we find the adjustment factor for stop-and-go traffic to be 1.8.

We also remember that we have no buses in the nighttime period and find the factor in Table 5 on page 8 for zero nighttime operations to be 0.43.

Our final adjusted ADT is (column 24)

$$1.8 \times 0.43 \times 270 = 209 \text{ Vehicles}$$

From Workchart 2, with an effective distance of 174 feet, we find a DNL of 59 dB.

trucks and enter it in column 25. Subtract these attenuation values from the DNL values obtained previously (columns 14 and 24), entering the reduced DNL values in columns 16 and 27. Combine the automobile and heavy truck DNL values, reduced by the attenuation provided by the barrier, to find the final DNL produced by the roadway at the site.

Remember to combine the contributions to DNL of all roads that affect the noise environment at each NAL for the site to obtain the total DNL from all roadways. Enter this DNL on both Worksheet C and the summary Worksheet A.

Attenuation of Noise by Barriers

Noise barriers are useful for shielding sensitive locations from ground level noise sources. For example, a barrier may be the best way to deal with housing sites at which the noise exposure is not acceptable because of nearby roadway traffic.

A barrier may be formed by the road profile; by a solid wall or embankment, by a continuous row of noise-compatible buildings, or by the terrain itself. To be an effective shield, however, the barrier must block all residential levels from line of sight to the road; it must not have any gaps that would allow noise to leak through.

Some Preliminary Matters:

In evaluating noise barrier performance, you will be working with different kinds of "distances" between the sound source, the observer, and the barrier.

Actual Distance – the existing distance that would be measured using a tape measure with no corrections or adjustments. This may mean one of two things, depending on the application; either the:

- *slant distance* – the actual distance,

Example 12a: Road No. 3 is a depressed highway and the profile shields all residential levels of the housing from line of sight to the traffic. The average truck speed is 50 mph. The ADT for heavy trucks is 4400 vehicles. We adjust for average speed (from Table 7)

$$4400 \times 0.81 = 3564$$

and find from Workchart 2 that, with an effective distance of 270 feet, the DNL from truck noise would be 69 dB if no barrier existed. We proceed to analyze the barrier attenuation.

measured along the line of sight between two points; or the

- *map distance* – the actual distance, measured on a horizontal plane, between the two points, as on a map or on the project plan.

For an observer high in an apartment tower, the slant distance to the road may be much longer than the map distance.

Barrier effectiveness is expressed in terms of noise attenuation in decibels (dB), determined with the aid of Workchart 6. This numerical value is subtracted from the previously calculated DNL in order to find the resultant DNL at the Noise Assessment Location.

Note: A noise barrier can be considered as a means of protecting a site from noise even if it cannot wrap around the site to shield from view practically all of the source of noise at every sensitive location on the site. It must be recognized, however, that such a barrier is much less effective than an ideal barrier. (See Workchart 7 and Step 6 below.)

Barriers of reasonable height cannot be expected to protect housing more than a few stories above ground level. Barriers will generally protect the ground and the first two or three floors, but not the higher floors. If there are to be frequently occupied balconies on the upper levels, one solution is to move the building farther from the noise source and face the sensitive areas away from the noise.

Steps to Evaluate a Barrier

1. For the observer's position, use the mid-height of the highest residential level. For the source position, use the following heights (see Figure 7):

- autos, medium trucks, railway cars – the road or railway surface height
- heavy trucks – 8 feet above the road surface

- diesel locomotives or trains using horns or whistles at grade crossings – 15 feet above the rails.

Figure 7. Source Heights to Be Used in Roadway Barrier Designs

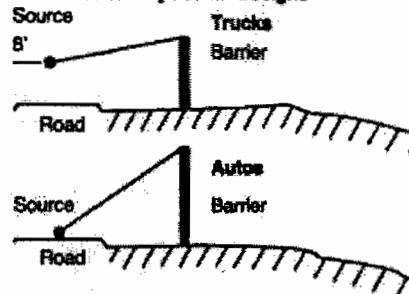

Get accurate values for the following quantities: *h*, the shortest distance from the barrier top to the line of sight from source to observer; *R* and *D*, the slant distances along the line of sight from the barrier to the source and observer, respectively (see Figure 8).

Figure 8. Generalized Geometry of Acoustical Barrier

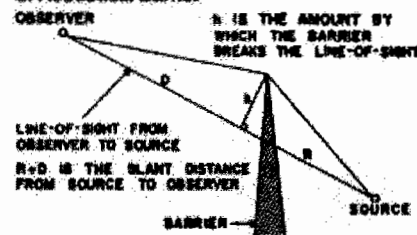

Specifically, *R* and *D* are the two segments into which *h* breaks the line of sight. Note that *h* is not the height of the barrier above the ground but the distance from the barrier top to the line of sight.

2. Enter at the top of Workchart 6 with the value of *h* on the left-hand scale; move right to intersect the curve corresponding to *R* (or *D*, whichever is smaller).

3. Move down to intersect the curve corresponding to the value of *D/R* (or *R/D*, whichever is smaller).

4. Move right to intersect the vertical scale in order to find the barrier shielding value *A* in decibels.

5. Interruption of the line of sight with a barrier between the noise source and an observer reduces the amount of sound attenuation provided by the ground. Find the amount of this loss *B* from the table on Workchart 6 by entering the table with the value of *D/R*. Find the barrier attenuation value *S* corresponding to an ideal barrier that completely hides the noise source from view by subtracting *B* from the value of *A* obtained in Step 4.

6. If the barrier exists along only a part of the road so that unshielded sections of the road would be visible from the site, the barrier is less effective than an ideal barrier. On a plan view of the site, locate the two ends of the barrier and draw lines from these points to the Noise Assessment Location. Use a protractor to measure the angle formed at the NAL by the two lines. Enter the horizontal scale of Workchart 7 with the values of this angle; read up to the curve having the value of *S* determined from Step 5 (interpolating if necessary); read left across to the vertical scale labeled "actual barrier performance" to find the value of *FS* to use for the actual barrier in question.

7. Subtract the barrier attenuation value *S* (or *FS* if adjusted for finite barrier length according to Workchart 7) from the value of DNL previously determined to reevaluate the site with the noise barrier in place.

Example 12b: (Refer to Figure 9.) Six stories are planned for the housing where the site has an elevation of 130 feet. The effective elevation for the highest story is found by multiplying the number of stories by 10 feet, adding the site elevation, and subtracting 5 feet.

$$(6 \times 10) + 130 - 5 = 185 \text{ feet}$$

The barrier, which in this case is formed by the road profile, has no "height" other than the elevation of the natural terrain above the noise sources traveling on the roadway. The important dimensions are indicated in Figure 9.

Some people with a technical background will be able to fit the geometric diagram to the site situation readily, working from the project drawings and a scratch sheet.

But if you are not confident of your geometry, Workchart 5 gets you the values of *R*, *D*, and *h* from the map distances and elevations of the site. We illustrate that procedure in this example.

First, enter the elevations of the source (*S*), the observer (*O*), and the top of the barrier (*H*), as well as the map distances from the barrier to the source (*R'*) and observer (*D'*), at the top right of Workchart 5. Then, follow the steps on that Workchart to derive the values of *h*, *R*, and *D* that are needed in using Workchart 6.

Entering Workchart 6 at the upper left with the value of *h* (5.5 feet), we move horizontally

Figure 9.
Detail of Site Showing Measurements
Necessary for a Barrier Adjustment

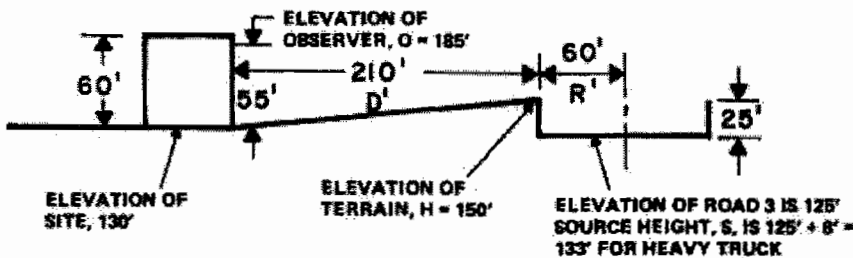

Figure 10.
Use of Workchart 5 to Determine Barrier
Dimensions in Example 12b

Workchart 5
Noise Barrier
To find R, D, and H from Site Elevations and Distances

Fill out the following equations (all quantities are in feet)

Create the values for:
 $h = 150$ $R = 60$
 $S = 133$ $D = 210$
 $O = 185$

- Elevation of barrier top minus elevation of source: $[150] - [133] = [17]$
- Elevation of observer minus elevation of source: $[185] - [133] = [52]$
- Map distance between source and observer (S): $[270]$
- Map distance between barrier and source (R): $[60]$
- Line 2 divided by line 3: $[52] \div [270] = [0.19]$
- Square the quantity on line 5 (always positive): $[0.19] \times [0.19] = [0.04]$
- 40% of line 6: $[0.04] \times 0.4 = [0.016]$
- One times line 7: $[0.016] - [0.016] = [0.984]$
- Line 5 times line 4 (if line 4 is negative): $[0.19] \times [60] = [11.4]$
- Line 1 minus line 8: $[17] - [11.4] = [5.6]$
- Line 10 times line 9: $[5.6] \times [0.984] = [5.5]$
- Line 8 times line 10: $[11.4] \times [0.984] = [11.2]$
- Line 4 divided by line 11: $[60] \div [11.2] = [5.3]$
- Line 10 plus line 12: $[5.5] + [11.2] = [16.7]$
- Line 2 minus line 13: $[52] - [16.7] = [35.3]$
- Line 13 divided by line 14: $[35.3] \div [16.7] = [2.1]$
- Line 15 minus line 12: $[2.1] - [11.2] = [-9.1]$

Notes: The value on line 1 may be negative. If such case, do not use the value on line 12, and line 15 may also be negative. Remember, plus, or minus. If R and D are equal, use R = D. If R and D are not equal, use the value on line 12. If the value on line 12 is negative, use the value on line 15. If the value on line 15 is negative, use the value on line 12.

to the right until we meet the value of R or D, whichever is smaller: in this example, R = 62 feet. From that point we drop vertically downward until we meet the value of R/D or D/R, whichever is smaller: in this case, R/D = 0.29. From that point, move horizontally to the right to find the value for A = 9 dB. Entering the table for determining loss of ground attenuation effect due to the barrier with a value for D/R of 3.5, the reduction in attenuation (B) is found to be 3 dB. Subtracting 3 dB from 9 dB provides a net attenuation of 6 dB. With 6 dB of attenuation, the original DNL of 69 dB (Example 12a) is reduced to 63 dB.

Example 13: An alternative approach, which is somewhat more direct, is illustrated here for the noise of automobiles on Road No. 3. A preliminary step is to make an accurately scaled sketch of the general geometry introduced on page 8. It must include the positions of the source (this time at the road surface), the observer, and the top of the barrier, and will show the distances h, R, and D. Such a sketch is shown superimposed on the profile of the road and its neighborhood in Figure 12.

Figure 11.
Use of Workchart 6 to Evaluate Barrier
in Examples 12b, 13 and 14

Noise Barrier Workchart 6

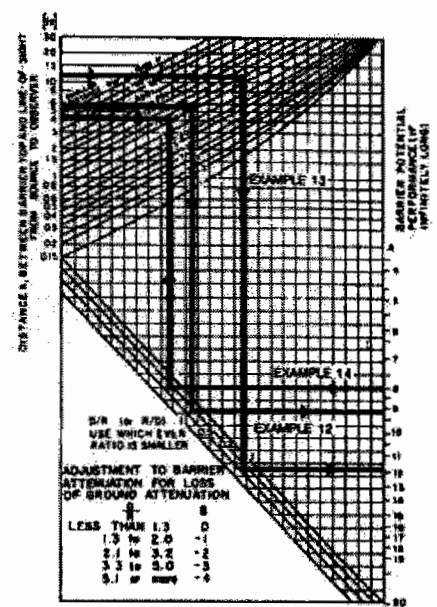

If we carefully scale the dimensions directly from this sketch, we find the following values for h, R, and D:
 $R = 63$ feet
 $R/D = 0.3$
 $D = 214$ feet
 $h = 11$ feet

The barrier attenuation is found, by entering Workchart 6 with these values, to be A = 12 dB. It is larger than that found for trucks because the noise source is lower and is, therefore, better shielded by the barrier. The loss from ground attenuation is again B = 3 dB for a net attenuation of 12 - 3 = 9 dB. In Example 9b, we found that the DNL

Figure 12.
Sketch Showing Dimensions for Example 13

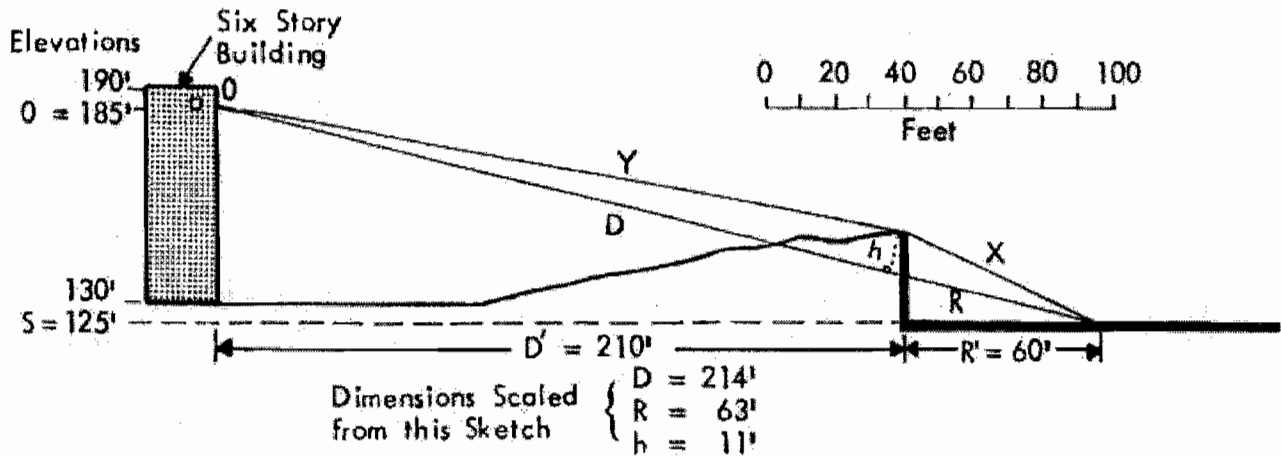

for the projected traffic volume of 100,000 vehicles per day was 69 dB if no consideration was given the shielding provided by the terrain. Subtracting the 9 dB attenuation from 69, we find the partial DNL for automobiles is 60 dB.

In order to find the combined truck and automobile noise for Road No. 3, we combine the 63 dB of truck noise with the 60 dB of automobile noise using Table 1. We find that 1.8 should be added to 63 dB, for a combined DNL of 64.8 dB, or 65 dB when rounded to the nearest whole number.

Example 14: Where no natural barrier exists, Workchart 6 can be used in reverse to estimate the height of a barrier needed to obtain a required attenuation. In example 9b we found that, without any attenuation from terrain or a barrier, the automobile traffic produced a DNL of 69 dB, and in Example 12a the heavy truck traffic produced a DNL of 69 dB. When combined, the total DNL is 72 dB. Suppose the terrain were not rising between the NAL and Road No. 3, as shown in Figure 12, but instead was level between the NAL and the edge of the road, as shown in Figure 13. We want to find out how high a wall, infinite in length, would be required at the edge of the road to reduce the combined truck and automobile noise to less than 65 dB. We have found in the previous examples that a barrier

of a given height will provide more attenuation for automobiles than it will for trucks. As a first step in our analysis, we will find the height of a wall that will reduce the truck noise to just below 65 dB, say 64 dB, and then find out whether the additional attenuation it provides for automobile noise will be sufficient to reduce the combined truck and automobile noise to less than 65 dB. We begin by finding the height of wall that will provide 5 dB attenuation for truck noise.

We estimate that the ratio of R/D is about the same as R'/D' , the ratio of horizontal distance in Figure 13, which is equal to 0.29. Before entering Workchart 6, we find from the loss of ground attenuation table that for $D/R = 3.4$ we will lose 3 dB attenuation from an ideal barrier. In order to have a net attenua-

Figure 13.
Sketch Showing Dimensions for Example 14

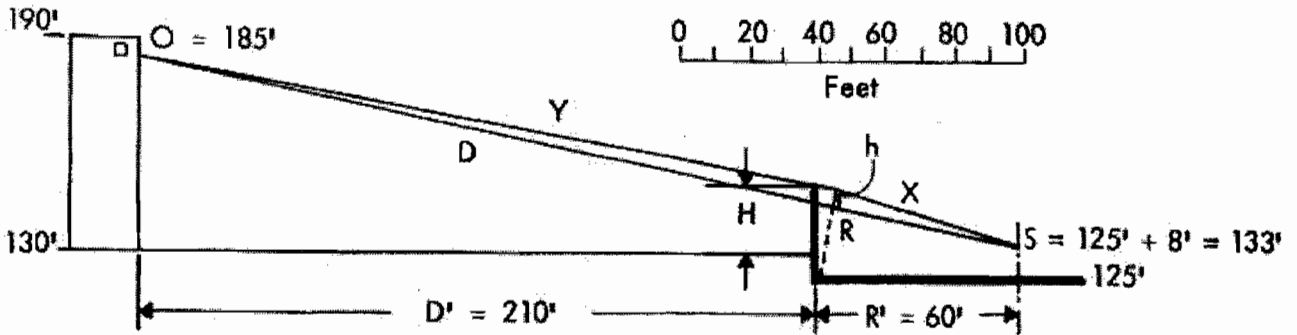

tion of 5 dB, we must have an ideal barrier that provides $5 + 3 = 8$ dB attenuation.

Entering Workchart 6 on the right side scale A at 8 decibels, we move across to the diagonal lines, finding 0.29 by interpolating between the lines marked at 0.2 and 0.5. Moving directly up to a point midway between the R lines of 50 and 70, we find our estimated R of approximately 60. Moving across to the left we find that the line of sight between the observer and the truck source height must be broken by a value of h equal to 4.5 feet.

We can determine the height of the wall H in several ways. By drawing $h = 4.5$ feet to scale on Figure 13, we can scale the total wall height H to be approximately 20 feet. Those who feel comfortable with geometry can

calculate H by using the similar triangle relationships in Figure 13 to determine that H is 19.1 feet.

Now we must find how much a wall 19 feet high will attenuate automobile noise, remembering that the source height for automobiles is at the road surface elevation of 125 feet. By scaling the drawing, or by geometry, we determine that the line of sight between the observer position and the automobile source is broken by a value of h that is approximately 13 feet. Entering Workchart 6 at 13 feet we find, for $R = 60$ feet and $R/D = 0.29$, that the potential barrier attenuation is 12dB. We must reduce this by 3 dB for loss of ground attenuation to find the actual shielding of automobile noise to be 9

dB. The original 69 dB of automobile noise is reduced to $69 - 9 = 60$ dB.

Finally, we combine the heavy truck noise, attenuated by the wall to $69 - 5 = 64$ dB, with the automobile noise reduced to 60 dB, to find a combined DNL of 65.5 dB, or 66 dB when rounded upward. Remember, however, that this is for an infinite wall. Further adjustments would have to be made once the actual length was known.

Railways

Necessary Information

To evaluate a site's exposure to railway noise, you will need to consider all rapid transit lines and railroads within 3000 feet of the site (except totally covered subways). The information required for this evaluation is listed below under headings that indicate the most likely source.

Before beginning the evaluation, you should record the following information on Worksheet D:

From the area map and/or the (County) Engineer:

- The distance from the appropriate NAL on the site to the center of the railway track carrying most of the traffic.

From the Supervisor of Customer Relations for the railway:

- The number of diesel trains and the number of electrified trains in both directions during an average 24-hour day.
- The fraction of trains that operate during nighttime (10 p.m. - 7 a.m.) If this is unknown, assume 0.15.
- The average number of diesel locomotives per train. If this is unknown, assume 2.
- The average number of railway cars per diesel train and per electrified train. If this is unknown, assume 50 for diesel trains and 8 for electrified trains.
- The average train speed. If this is unknown, assume 30 mph.
- Is the track made from welded or bolted rails?

From the Engineering Department of the railway:

- Is the site near a grade crossing that requires prolonged use of the train's horn or whistle? If so, where are the whistle posts located? (Whistle posts are signposts which

tell the engineer to start blowing the horn or whistle. Every grade crossing has whistle posts and they are listed on the railroad's "track charts." If traffic on the track is one-way, there will be only one whistle post. The grade crossing itself is the other "whistle post."

Electrified rapid transit and commuter trains that do not use diesel engines should be treated the same as railway cars.

Note: Buildings closer than 100 feet to a railroad track are often subject to excessive vibration transmitted through the ground. Construction at such sites is discouraged.

Evaluation of Site Exposure to Railway Noise

Railway noise is produced by the combination of diesel engine noise and railway car noise. These Guidelines provide for the separate evaluation of diesel locomotives and railroad cars, and then the combination of the two, in order to obtain the DNL from trains. When rapid transit or electrified trains that do not use diesel engines are the only trains passing near a site go directly to the second part of the evaluation since these trains are treated in the same manner as railway cars.

Diesel Locomotives

Workchart 3 was derived with the following assumptions:

- A clear line of sight exists between the railway track and the Noise Assessment Location.
- There are two diesel locomotives per train.
- The average train speed is 30 mph.
- Nighttime operations are 0.15 of the 24-hour total.
- The site is not near a grade crossing re-

quiring prolonged use of the train's horn or whistle.

If the situation meets these conditions, proceed to Workchart 3 for an immediate evaluation of diesel locomotive noise.

But:

If any of the conditions is different, make the necessary adjustments listed below and then use Workchart 3 for the evaluation.

Figure 14.
Use of Workchart 3 to Evaluate Diesel Locomotive Noise

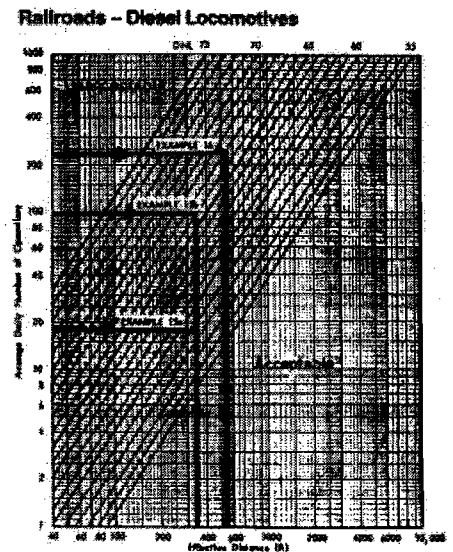

Adjustments for Diesel Locomotives

Number of Locomotives:

If the average number of diesel locomotives per train is not 2, divide the average number by 2. Enter this value in column 9 of Worksheet D.

Example 15a: The distance from NAL number 1 to Railway Number 1 is 339 feet. Two percent of the 35 daily operations occur at night; there is clear line of sight between the tracks and the NAL, and no horns or whistles are used. No information is available on train size or speed, therefore we will assume 2 engines per train and a speed of 30 mph.

Since the percentage of nighttime operations is different from 15 percent, we must adjust the actual number of daily operations, multiplying by 0.50 according to Table 5.

$$0.50 \times 35 = 17.5 = 18$$

Entering Workchart 3 with 18 daily operations and a distance of 339 feet, we find that

the contribution of diesel engine noise is a DNL of 59 dB (see Figure 14).

In order to find the total contribution of the trains to the total DNL, we must also find the noise level produced by the train's cars. Entering Workchart 4 (see Figure 15) with 18 daily operations and a distance of 339 feet, we find the DNL is below 50 on the chart, or more than 10 decibels lower than the noise level produced by the engines. Based on the chart for decibel addition, the combination of the noise from the engines and the cars adds less than 0.5 decibels to the DNL value for the engines alone, 59 dB.

Example 15b: Suppose that a forecast of train operations for Railway 1 indicates that there will still be 35 trains per day, but now 50 percent of the operations will occur at night, the average train will have 4 engines and 75 cars, and the average speed will be 50 mph.

We first find the contribution to DNL made by diesel locomotives by using the following adjustment factors:

- number of engines adjustment: 2
- speed adjustment: 0.60
- day/night adjustment: 2.34

We multiply these adjustments together with the number of trains:

$$2 \times 0.60 \times 2.34 \times 35 = 98$$

Entering Workchart 3 (see Figure 14) with 98 daily operations and a distance of 339

Average Train Speed:

If the average train speed is different from 30 mph, find the appropriate adjustment factor from Table 9 and list in column 10 of Worksheet D.

Table 9

| Average Speed (mph) | Speed Adjustment Factor |
|---------------------|-------------------------|
| 10 | 3.00 |
| 20 | 1.50 |
| 30 | 1.00 |
| 40 | 0.75 |
| 50 | 0.60 |
| 60 | 0.50 |
| 70 | 0.43 |

Horns or Whistles:

If the NAL is perpendicular to any point on the track between the whistle posts for the grade crossing, enter the number 10 in column 11, Worksheet D.

Nighttime Adjustment:

Remember to adjust for nighttime operations, if different from 0.15 of the total, by selecting the appropriate adjustment factor from Table 5 on page 8. Enter in column 12, Worksheet D.

Multiply the adjustment factors together, times the number of diesel trains per day (you have listed this number previously on line 2a, page 1, of Worksheet D, and should enter this number again in column 13) to obtain the adjusted number of trains per day. Enter the adjusted number of diesel trains per day in column 14. Use this value, in conjunction with the distance from the NAL to the track (line 1, page 1, of Worksheet D), to find from Workchart 3 the DNL produced by diesel locomotives. List in column 15 of Worksheet D.

Railway Cars and Rapid Transit Systems

Workchart 4 was derived with the following assumptions:

- A clear line of sight exists between the railway and the NAL.
- There are 50 cars per train.
- The average train speed is 30 mph.
- Nighttime operations are 0.15 of the 24-hour total.
- Rails are welded together.

If the situation meets these conditions, proceed to Workchart 4 for an immediate evaluation of railway car noise. Again, if any of the conditions is different, make the necessary adjustments listed below and then use Workchart 4 for the evaluation.

Adjustments for Railway Cars and Rapid Transit Trains

Number of Cars:

Divide the average number of cars by 50 and enter this number in column 18 of Workchart D.

Average Speed:

Make this adjustment, if the average speed is not 30 mph, by selecting the appropriate value from Table 10, entering it in column 19 of Worksheet D.

Table 10

| Average Speed (mph) | Speed Adjustment Factor |
|---------------------|-------------------------|
| 10 | 0.11 |
| 20 | 0.44 |
| 30 | 1.00 |
| 40 | 1.78 |
| 50 | 2.78 |
| 60 | 4.00 |
| 70 | 5.44 |
| 80 | 7.11 |
| 90 | 9.00 |
| 100 | 11.11 |

Bolted Rails:

Enter the number 4 in column 20 of Worksheet D.

Nighttime Adjustment:

Enter the appropriate adjustment factor from Table 5 in column 21 of Worksheet D.

Figure 15. Use of Workchart 4 to Evaluate Railway Car Noise

Railroads - Cars and Rapid Transit

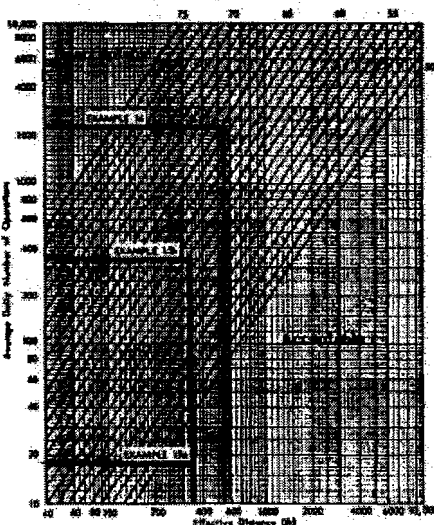

feet, we find that the site has an engine noise contribution to DNL of 66 dB.

We next obtain the adjustment factors for the noise produced by the cars:

- number of cars adjustment: 1.50
- speed adjustment: 2.78
- day/night adjustment: 2.34

Multiplying the adjustment factors times the average daily number of trains:

$$1.5 \times 2.78 \times 2.34 \times 35 = 342$$

Entering Workchart 4 (see Figure 15) with 342 operations and a distance of 339 feet, we find the contribution of the cars to the DNL is 60 dB. Using Table 1 for combining levels, we find that the 6 dB difference between engine noise at 66 and car noise at 60 gives a combined DNL of 67 dB for these trains.

Example 16: The distance from NAL number 2 to Railroad Number 2 is 550 feet; there are 100 operations per day, of which 30 percent occur at night. A clear line of sight exists between the site and the railroad, and no horns or whistles are used nearby. An average train on this track uses 4 engines, has 100 cars, the average speed is 40 miles per hour, and the track has bolted, not welded, rails.

We first find the adjustment factors for the diesel engines:

- number of engines adjustment: 2
- speed adjustment: 0.75
- day/night adjustment: 1.57

Multiplying the adjustments together, times the number of trains:

$$2 \times 0.75 \times 1.57 \times 100 = 236$$

Entering Workchart 3 (see Figure 14) with 236 operations at a distance of 550 feet, we find the DNL contribution from engine noise to be 67 dB.

Next we find the adjustment factors for the railroad cars:

- number of cars adjustment: 2
- speed adjustment: 1.78
- bolted track adjustment: 4
- day/night adjustment: 1.57

Multiplying the adjustments together, times the number of trains:

$$2 \times 1.78 \times 4 \times 1.57 \times 100 = 2236$$

Entering Workchart 4 (see Figure 15) with

(Continued next page)

Figure 16. Sketch Showing Dimensions for Example 16

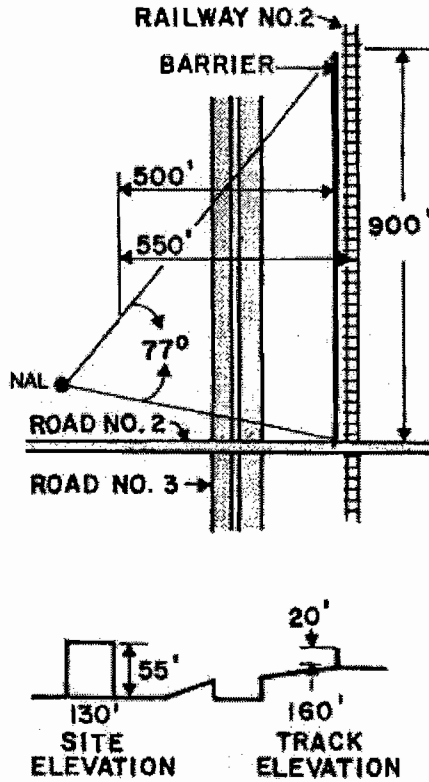

Figure 17. Use of Workchart 6 in Example 16

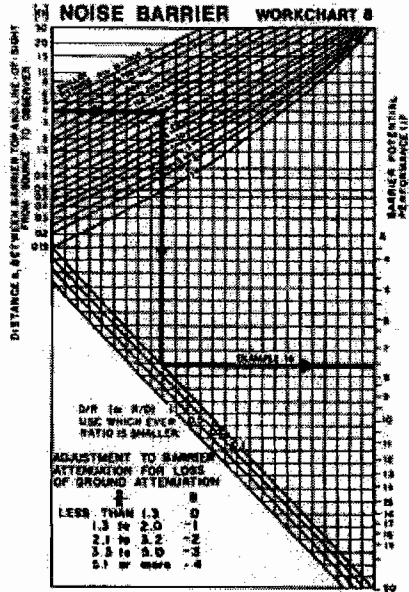
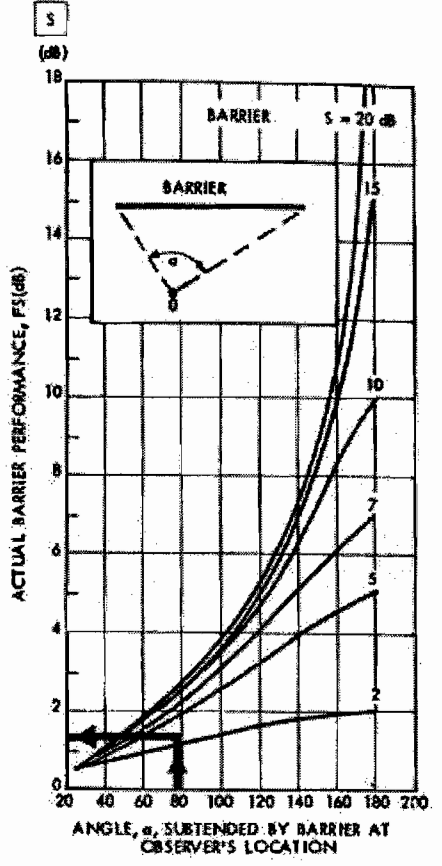

Figure 18. Use of Workchart 7 in Example 16



2236 operations at a distance of 550 feet, we find the DNL contribution from the railroad cars to be 65 dB. Combining the engine sound levels with the car sound levels we find the total DNL from the trains to be 69 dB.

It would be possible to erect a 20-foot noise barrier, running parallel to the track at a distance of 50 feet; it could start at Road Number 2 and run 900 feet north toward the airport, as shown in Figure 16. Both the railroad track and the ground level at the barrier location are at an elevation of 160 feet. Thus, we have the following values with which to calculate the potential reduction in engine noise (using Workchart 5). (Because the distances involved are so unequal, this situation does

not lend itself to direct scaling of the distances.)

- $H = 180$ feet (20' above the ground)
- $S = 175$ feet (15' above the track, see page 19)
- $O = 285$ feet (from Example 11 in the section on roadway noise)
- $R' = 50$ feet
- $D' = 500$ feet

We find from Worksheet 5 that the values of R and D are no different (within the accuracy of the calculation) from R' and D' , a situation that will always occur when the differences in elevation are so much smaller than the distances from the site to the noise source. The value of h is 4 feet; $R/D = 0.1$

We can now use these numbers to enter Workchart 6 to find the potential barrier performance (that is, the barrier adjustment factor that would apply in the case of an infinitely long barrier). Entering Workchart 6 at $h = 4$ feet, with $R/D = 0.1$, we find the basic attenuation of the barrier to be 7.5 dB. However, with $D/R = 10$, we find from the table of loss-of-ground-effect attenuation that we must subtract 4 dB from the 7.5, or a net effect of 3.5 dB. However, the situation is even worse, since the barrier is finite in length.

To find the actual attenuation for this finite barrier, we must first find the angle subtended by the barrier to the NAL. Referring to Figure 16, we draw lines from the NAL each end of the barrier. With

References

1. D.E. Bishop, A.P. Hays, "Handbook for Developing Noise Exposure Contours for General Aviation Airports," FAA-AS-75-1, December 1975 (NTIS No. AD-A023429).
2. D.E. Bishop, et al., "Calculation of Day-Night Levels Resulting From Civil Aircraft Operations," BBN Report 3157 for Environmental Protection Agency, March 1976 (NTIS No. PB 266 165).
3. B.A. Kugler, D.E. Commins, W.J. Galloway, "Highway Noise - A Design Guide for Prediction and Control," NCHRP Report 174, Transportation Research Board, National Research Council, 1976.
4. T.J. Schultz, W.J. Galloway, "Noise Assessment Guidelines - Technical Background," Office of Policy Development and Research, U.S. Department of Housing and Urban Development, 1980.
5. M.A. Simpson, "Noise Barrier Design Handbook," FHWA-RD-76-58, Federal Highway Administration, February 1976 (NTIS No. PB 266 378).

a protractor we measure the angle between the two lines to be 77 degrees. Locate the curve on Workchart 7 corresponding to the potential barrier attenuation of 3.5 dB; it lies midway between the two lowest curves (see Figure 18). The point on this curve corresponding to a subtended angle of 77 degrees indicates that the actual barrier performance would be only 1.5 dB. With only 1.5 dB of attenuation, the barrier is clearly not cost-effective. In order to achieve a usable attenuation from the barrier, it would have to be extended beyond the other side of Road Number 2 to obtain a larger subtended angle. This extension, however, would still not be cost-effective unless the height of the barrier were increased substantially.

Summary of Adjustment Factors

Combination of Sound Levels

Table 1

| Difference in Sound Level | Add to Larger Level |
|---------------------------|---------------------|
| 0 | 3.0 |
| 1 | 2.5 |
| 2 | 2.1 |
| 3 | 1.8 |
| 4 | 1.5 |
| 5 | 1.2 |
| 6 | 1.0 |
| 7 | 0.8 |
| 8 | 0.6 |
| 9 | 0.5 |
| 10 | 0.4 |
| 12 | 0.3 |
| 14 | 0.2 |
| 16 | 0.1 |
| greater than 16 | 0. |

Aircraft

Table 2 DNL Outside 65 dB Contour

D¹ = distance from 65 dB contour to flight path
D² = distance from site to flight path

| D ² /D ¹ | DNL dB |
|--------------------------------|--------|
| 1.0 | 65 |
| 1.12 | 64 |
| 1.26 | 63 |
| 1.41 | 62 |
| 1.58 | 61 |
| 1.78 | 60 |
| 2.00 | 59 |
| 2.24 | 58 |
| 2.51 | 57 |
| 2.82 | 56 |
| 3.16 | 55 |

Automobile Traffic

Table 3 Stop-and-go

| Distance from Site to Stop Sign feet | Automobile Stop-and-go Adjustment Factor |
|--------------------------------------|--|
| 0 | 0.10 |
| 100 | 0.25 |
| 200 | 0.40 |
| 300 | 0.55 |
| 400 | 0.70 |
| 500 | 0.85 |
| 600 | 1.00 |

Table 4 Average Traffic Speed

| Average Traffic Speed | Adjustment Factor |
|-----------------------|-------------------|
| 20 (mph) | 0.13 |
| 25 | 0.21 |
| 30 | 0.30 |
| 35 | 0.40 |
| 40 | 0.53 |
| 45 | 0.67 |
| 50 | 0.83 |
| 55 | 1.00 |
| 60 | 1.19 |
| 65 | 1.40 |
| 70 | 1.62 |

Table 5 Nighttime (applies to all sources)

| Nighttime Fraction of ADT | Nighttime Adjustment Factor |
|---------------------------|-----------------------------|
| 0 | 0.43 |
| 0.01 | 0.46 |
| 0.02 | 0.50 |
| 0.05 | 0.62 |
| 0.10 | 0.81 |
| 0.15 | 1.00 |
| 0.20 | 1.19 |
| 0.25 | 1.38 |
| 0.30 | 1.57 |
| 0.35 | 1.78 |
| 0.40 | 1.96 |
| 0.45 | 2.15 |
| 0.50 | 2.34 |

Medium Trucks

(less than 26,000 pounds, greater than 10,000 pounds)

Multiply adjusted automobile traffic by 10.

Heavy Trucks

Table 6 Road Gradient

| Percent of Adjustment Gradient Factor | |
|---------------------------------------|-----|
| 2 | 1.4 |
| 3 | 1.7 |
| 4 | 2.0 |
| 5 | 2.2 |
| 6 or more | 2.5 |

Table 7 Average Speed

| Average Traffic Speed (mph) | Truck Speed Adjustment Factor |
|-----------------------------|-------------------------------|
| 50 or less | 0.81 |
| 55 | 1.00 |
| 60 | 1.17 |
| 65 | 1.38 |

Table 8 Stop-and-go

| Heavy Truck Traffic Volume per Day | Heavy Truck Stop-and-Go Adjustment Factor |
|------------------------------------|---|
| Less than 1200 | 1.8 |
| 1201 to 2400 | 2.0 |
| 2401 to 4800 | 2.3 |
| 4801 to 9600 | 2.8 |
| 9601 to 19,200 | 3.8 |
| More than 19,200 | 4.5 |

Railroads - Diesel Engines

Number of Engines per Train
The number of engines divided by 2.

Table 9 Average Train Speed

| Average Speed (mph) | Speed Adjustment Factor |
|---------------------|-------------------------|
| 10 | 3.00 |
| 20 | 1.50 |
| 30 | 1.00 |
| 40 | 0.75 |
| 50 | 0.60 |
| 60 | 0.50 |
| 70 | 0.43 |

Whistles or horns
Multiply number of trains by 10.

Railroads - Cars and Rapid Transit

Numbers of cars.
Number of cars per train divided by 50.

Table 10 Average Train Speed

| Average Speed (mph) | Speed Adjustment Factor |
|---------------------|-------------------------|
| 10 | 0.11 |
| 20 | 0.44 |
| 30 | 1.00 |
| 40 | 1.78 |
| 50 | 2.78 |
| 60 | 4.00 |
| 70 | 5.44 |
| 80 | 7.11 |
| 90 | 9.00 |
| 100 | 11.11 |

Bolted Rails

Multiply number of trains by 4.

Whistles or Horns

Multiply number of trains by 100.

**Workchart 1
Autos (55 mph)**

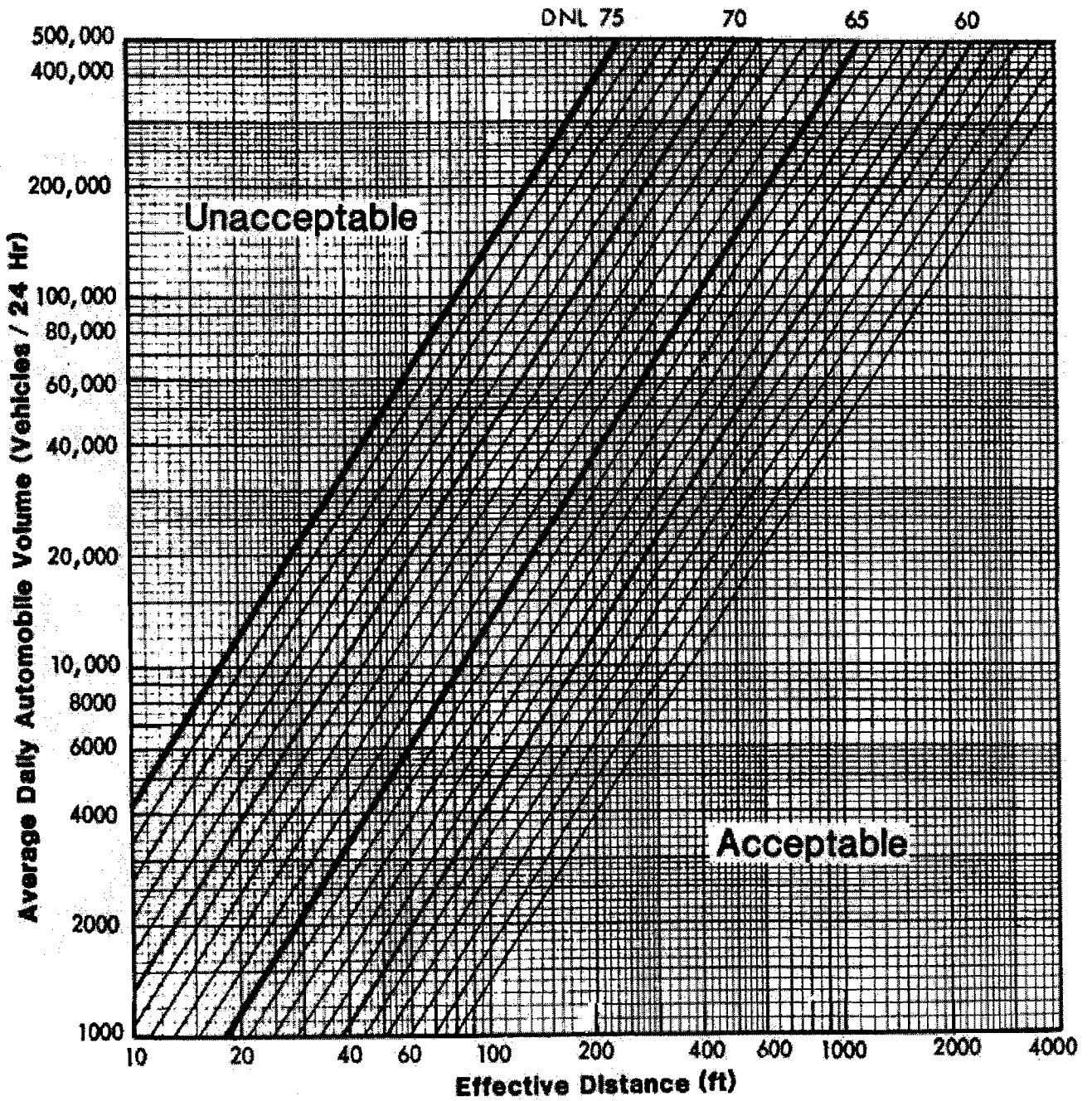

**Workchart 2
Heavy Trucks (55 mph)**

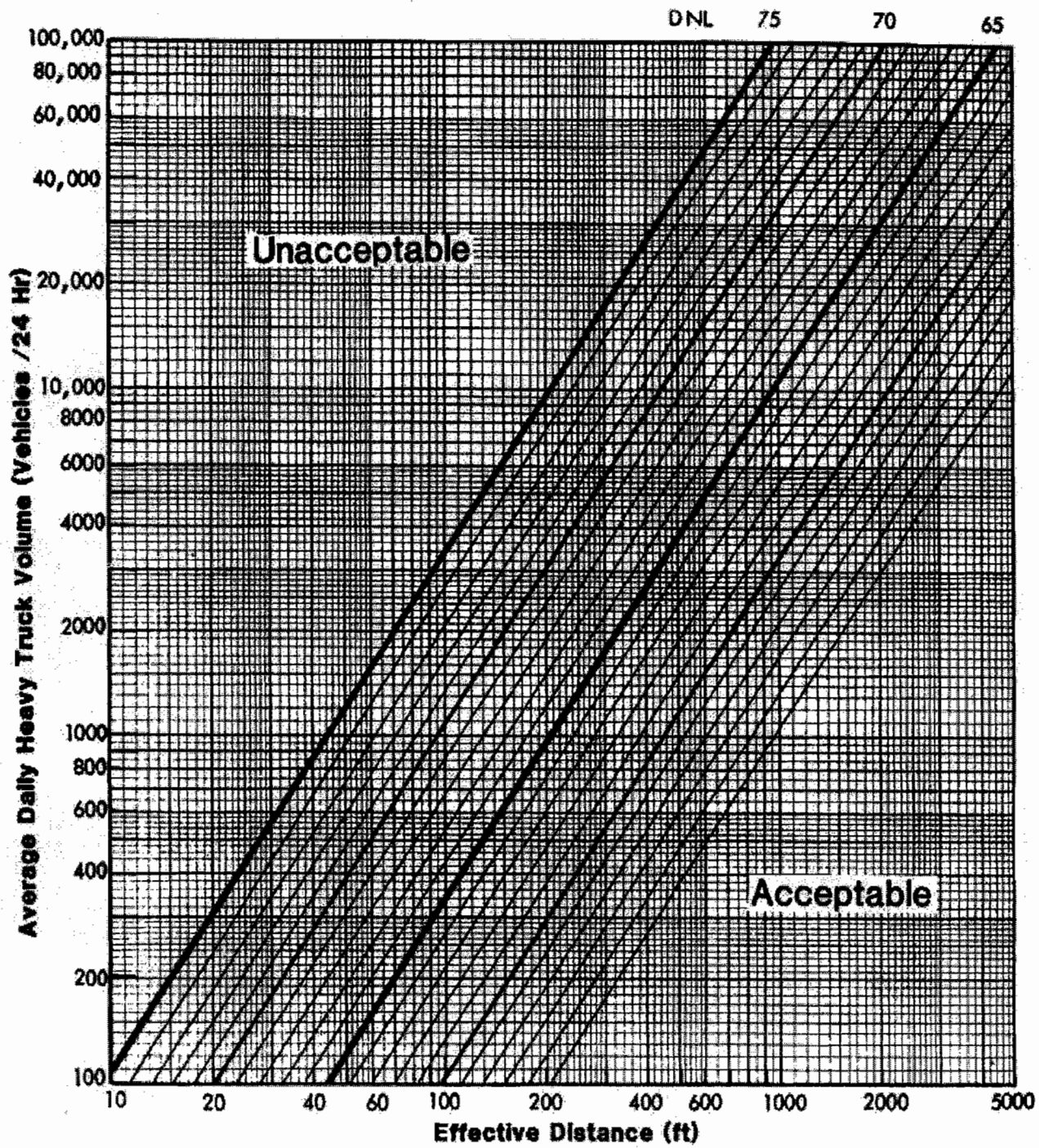

**Workchart 3
Railroads - Diesel Locomotives**

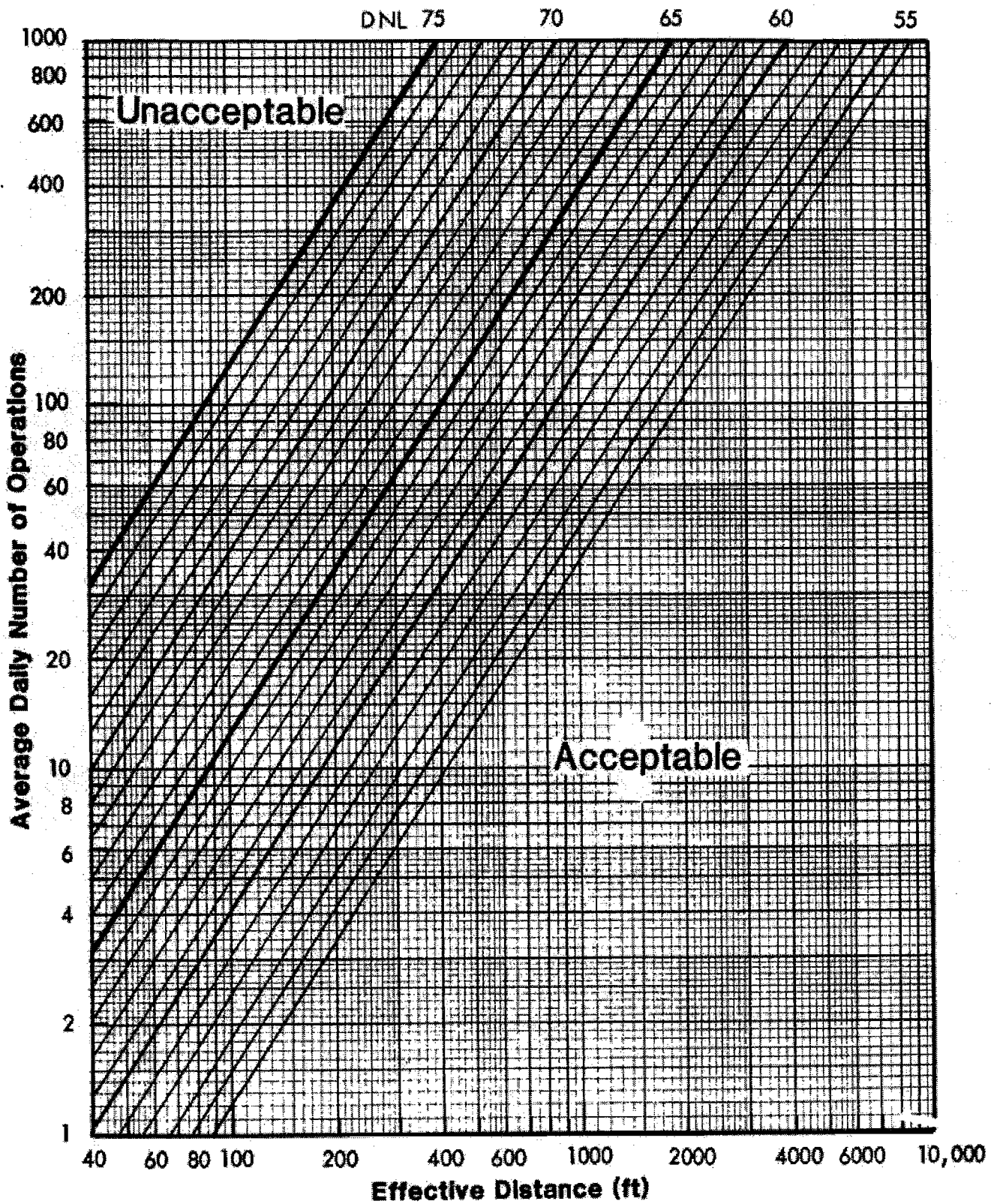

Workchart 4
Railroads - Cars and Rapid Transit

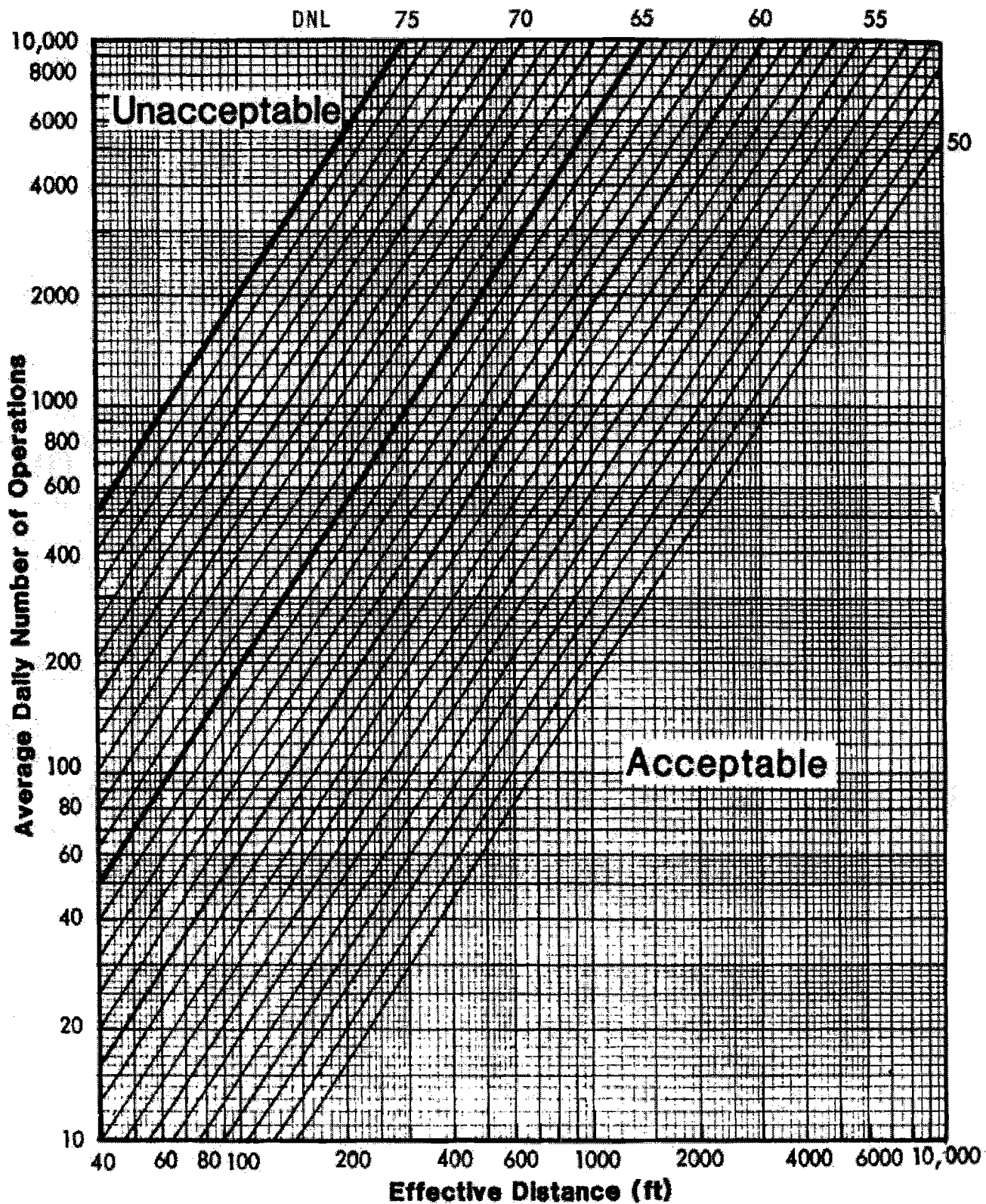

Workchart 5 Noise Barrier

To find R, D and h from Site Elevations and Distances

Fill out the following worksheet (all quantities are in feet):

Enter the values for:

H = _____ R' = _____

S = _____ D' = _____

O = _____

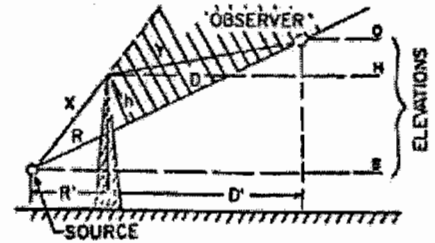

- | | |
|--|------------------------------|
| 1. Elevation of barrier top minus elevation of source | [H] - [S] = [1] |
| 2. Elevation of observer minus elevation of source | [O] - [S] = [2] |
| 3. Map distance between source and observer (R' + D') | [3] |
| 4. Map distance between barrier and source (R') | [4] |
| 5. Line 2 divided by line 3 | [2] ÷ [3] = [5] |
| 6. Square the quantity on line 5 (i.e., multiply it by itself): always positive | [5] × [5] = [6] |
| 7. 40% of line 6 | [0.4] × [6] = [7] |
| 8. One minus line 7 | [1.0] - [7] = [8] |
| 9. Line 5 times line 4 (will be negative if line 2 is negative) | [5] × [4] = [9] |
| 10. Line 1 minus line 9 | [1] - [9] = [10] |
| 11. Line 10 times line 8 | [10] × [8] = [11] = h |
| 12. Line 5 times line 10 | [5] × [10] = [12] |
| 13. Line 4 divided by line 8 | [4] ÷ [8] = [13] |
| 14. Line 13 plus line 12 | [13] + [12] = [14] = R |
| 15. Line 3 minus line 4 | [3] - [4] = [15] |
| 16. Line 15 divided by line 8 | [15] ÷ [8] = [16] |
| 17. Line 16 minus line 12 | [16] - [12] = [17] = D |

[Note: the value on line 2 may be negative, in which case so will the values on lines 5, 9, and 12; line 1 may also be negative. Remember, then, in

lines 10, 14, and 17, that adding a negative number is the same as subtracting:
 $x + (-y) = x - y$. And subtracting a negative number is like adding: $x - (-y) = x + y$.

Round off R and D to nearest integer, h to one decimal place.

**Workchart 6
Noise Barrier**

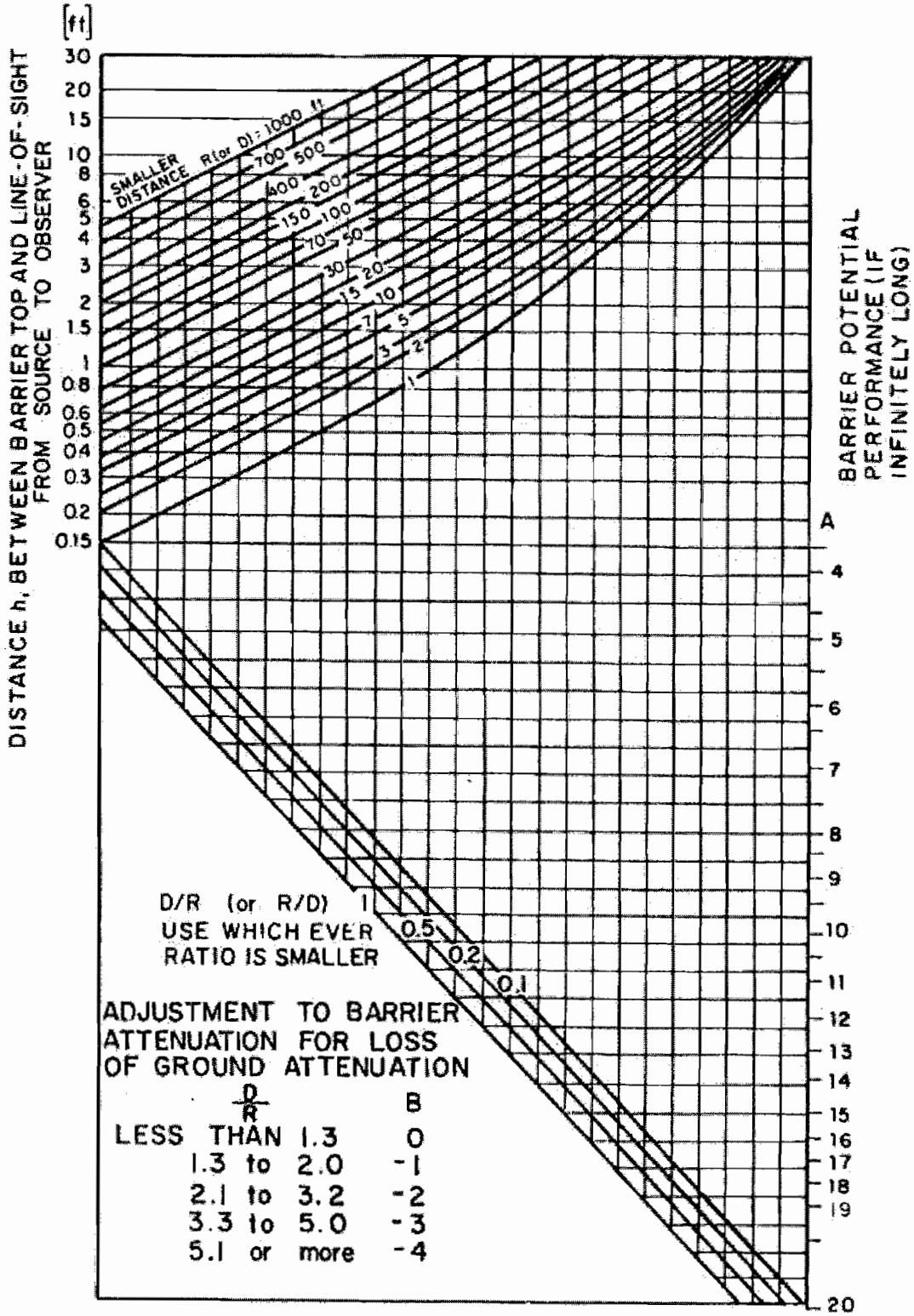

Workchart 7

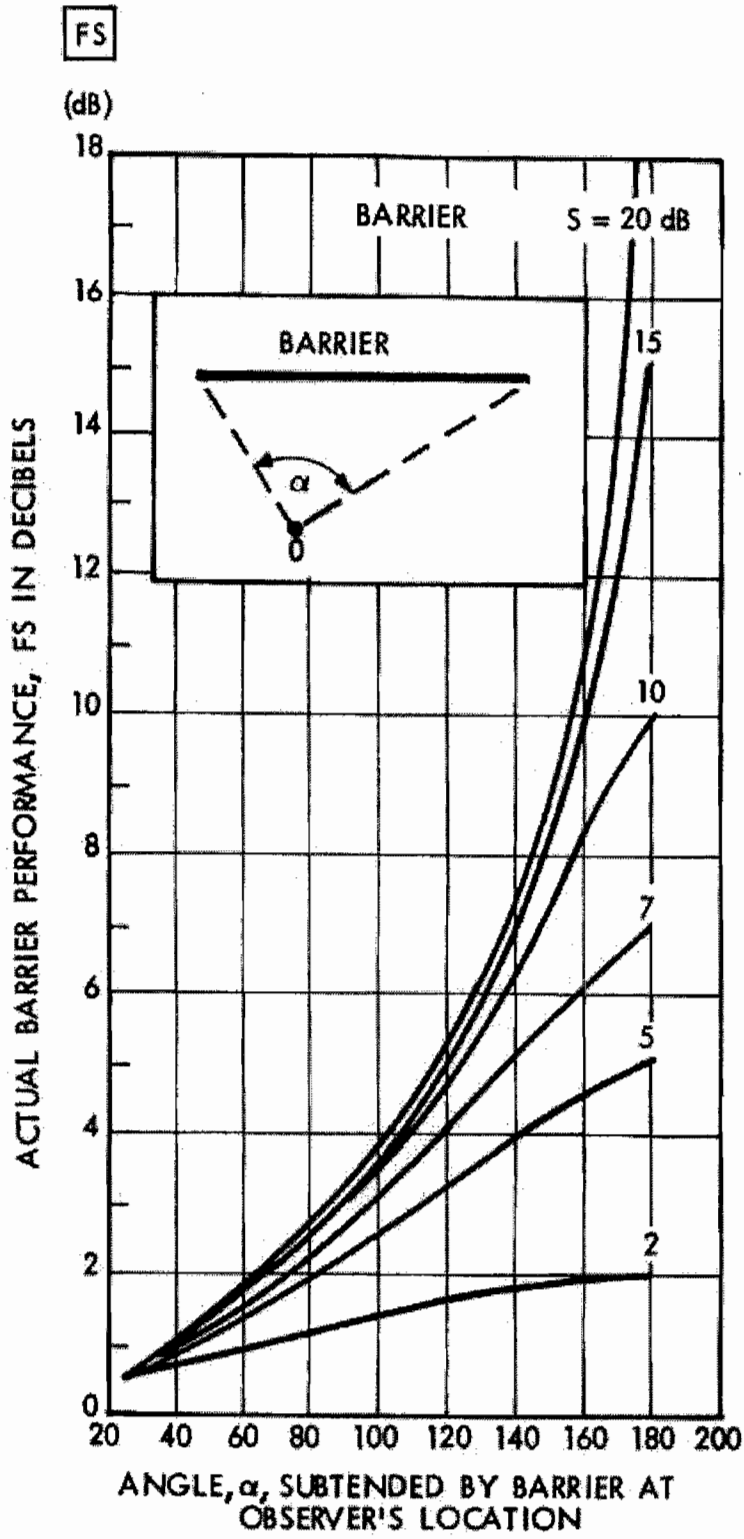

Correction to be applied to barrier potential in order to find the actual performance of the barrier of the same construction but of finite length.

**Worksheet A
Site Evaluation**

Noise Assessment Guidelines

Site Location _____

Program _____

Project Name _____

Locality _____

File Number _____

Sponsor's Name _____

Phone _____

Street Address _____

City, State _____

| | Acceptability Category | DNL | Predicted for Operations in Year |
|---|---------------------------|-------|-------------------------------------|
| 1. Roadway Noise | _____ | _____ | _____ |
| 2. Aircraft Noise | _____ | _____ | _____ |
| 3. Railway Noise | _____ | _____ | _____ |
| Value of DNL for all noise sources: (see page 3 for combination procedure) | | _____ | |

Final Site Evaluation (circle one)

Acceptable

Normally Unacceptable

Unacceptable

Signature _____

Date _____

Clip this worksheet to the top of a package
containing Worksheets B-E and Workcharts 1-7
that are used in the site evaluations

**Worksheet B
Aircraft Noise**

Noise Assessment Guidelines

List all airports within 15 miles of the site:

1. _____
2. _____
3. _____

Necessary information:

| | Airport 1 | Airport 2 | Airport 3 |
|--|-----------|-----------|-----------|
| 1. Are DNL, NEF or CNR contours available? (yes/no) | _____ | _____ | _____ |
| 2. Any supersonic aircraft operations? (yes/no) | _____ | _____ | _____ |
| 3. Estimating approximate contours from Figure 3: | | | |
| a. number of nighttime jet operations | _____ | _____ | _____ |
| b. number of daytime jet operations | _____ | _____ | _____ |
| c. effective number of operations (10 times a + b) | _____ | _____ | _____ |
| d. distance A for 65 dB | _____ | _____ | _____ |
| 70dB | _____ | _____ | _____ |
| 75 dB | _____ | _____ | _____ |
| e. distance B for 65 dB | _____ | _____ | _____ |
| 70 dB | _____ | _____ | _____ |
| 75 dB | _____ | _____ | _____ |
| 4. Estimating DNL from Table 2: | | | |
| a. distance from 65 dB contour to flight path, D ¹ | _____ | _____ | _____ |
| b. distance from NAL to flight path, D ² | _____ | _____ | _____ |
| c. D ² divided by D ¹ | _____ | _____ | _____ |
| d. DNL | _____ | _____ | _____ |
| 5. Operations projected for what year? | _____ | _____ | _____ |
| 6. Total DNL from all airports | _____ | _____ | _____ |

Signed _____

Date _____

List all major roads within 1000 feet of the site:

1. _____
2. _____
3. _____
4. _____

| Necessary Information | Road 1 | Road 2 | Road 3 | Road 4 |
|---|--------|--------|--------|--------|
| 1. Distance in feet from the NAL to the edge of the road | | | | |
| a. nearest lane | _____ | _____ | _____ | _____ |
| b. farthest lane | _____ | _____ | _____ | _____ |
| c. average (effective distance) | _____ | _____ | _____ | _____ |
| 2. Distance to stop sign | _____ | _____ | _____ | _____ |
| 3. Road gradient in percent | _____ | _____ | _____ | _____ |
| 4. Average speed in mph | | | | |
| a. Automobiles | _____ | _____ | _____ | _____ |
| b. heavy trucks - uphill | _____ | _____ | _____ | _____ |
| c. heavy trucks - downhill | _____ | _____ | _____ | _____ |
| 5. 24 hour average number of automobiles and medium trucks in both directions (ADT) | | | | |
| a. automobiles | _____ | _____ | _____ | _____ |
| b. medium trucks | _____ | _____ | _____ | _____ |
| c. effective ADT (a + (10xb)) | _____ | _____ | _____ | _____ |
| 6. 24 hour average number of heavy trucks | | | | |
| a. uphill | _____ | _____ | _____ | _____ |
| b. downhill | _____ | _____ | _____ | _____ |
| c. total | _____ | _____ | _____ | _____ |
| 7. Fraction of nighttime traffic (10 p.m. to 7 a.m.) | _____ | _____ | _____ | _____ |
| 8. Traffic projected for what year? | _____ | _____ | _____ | _____ |

Adjustments for Automobile Traffic

| | 9 Stop and-go Table 3 | 10 Average Speed Table 4 | 11 Night- Time Table 5 | 12 Auto ADT (line 5c) | 13 Adjusted Auto ADT | 14 DNL (Workchart 1) | 15 Barrier Attenuation | 16 Partial DNL |
|------------|--------------------------------|-----------------------------------|---------------------------------|--------------------------------|----------------------------|----------------------------|------------------------------|----------------------|
| Road No. 1 | _____ X _____ | _____ X _____ | _____ X _____ | _____ X _____ | = _____ | _____ - _____ | _____ = _____ | |
| Road No. 2 | _____ X _____ | _____ X _____ | _____ X _____ | _____ X _____ | = _____ | _____ - _____ | _____ = _____ | |
| Road No. 3 | _____ X _____ | _____ X _____ | _____ X _____ | _____ X _____ | = _____ | _____ - _____ | _____ = _____ | |
| Road No. 4 | _____ X _____ | _____ X _____ | _____ X _____ | _____ X _____ | = _____ | _____ - _____ | _____ = _____ | |

Adjustments for Heavy Truck Traffic

| | 17 Gradient Table 6 | 18 Average Speed Table 7 | 19 Truck ADT 2 | 20 | 21 | 22 Stop and-go Table 8 | 23 Night- Time Table 5 | 24 Adjusted Truck ADT | 25 DNL (Work- chart 2) | 26 Barrier Attn. | 27 Partial DNL |
|------------|---------------------------|-----------------------------------|-------------------------|---------------|---------------|---------------------------------|---------------------------------|--------------------------------|---------------------------------|------------------------|----------------------|
| Uphill | _____ X _____ | _____ X _____ | _____ X _____ | _____ X _____ | _____ X _____ | _____ X _____ | _____ X _____ | _____ X _____ | _____ X _____ | _____ X _____ | _____ X _____ |
| Road No. 1 | | | | | Add _____ | X _____ | X _____ | X _____ | X _____ | X _____ | X _____ |
| Downhill | _____ X _____ | _____ X _____ | _____ X _____ | _____ X _____ | _____ X _____ | _____ X _____ | _____ X _____ | _____ X _____ | _____ X _____ | _____ X _____ | _____ X _____ |
| Uphill | _____ X _____ | _____ X _____ | _____ X _____ | _____ X _____ | _____ X _____ | _____ X _____ | _____ X _____ | _____ X _____ | _____ X _____ | _____ X _____ | _____ X _____ |
| Road No. 2 | | | | | Add _____ | X _____ | X _____ | X _____ | X _____ | X _____ | X _____ |
| Downhill | _____ X _____ | _____ X _____ | _____ X _____ | _____ X _____ | _____ X _____ | _____ X _____ | _____ X _____ | _____ X _____ | _____ X _____ | _____ X _____ | _____ X _____ |
| Uphill | _____ X _____ | _____ X _____ | _____ X _____ | _____ X _____ | _____ X _____ | _____ X _____ | _____ X _____ | _____ X _____ | _____ X _____ | _____ X _____ | _____ X _____ |
| Road No. 3 | | | | | Add _____ | X _____ | X _____ | X _____ | X _____ | X _____ | X _____ |
| Downhill | _____ X _____ | _____ X _____ | _____ X _____ | _____ X _____ | _____ X _____ | _____ X _____ | _____ X _____ | _____ X _____ | _____ X _____ | _____ X _____ | _____ X _____ |
| Uphill | _____ X _____ | _____ X _____ | _____ X _____ | _____ X _____ | _____ X _____ | _____ X _____ | _____ X _____ | _____ X _____ | _____ X _____ | _____ X _____ | _____ X _____ |
| Road No. 4 | | | | | Add _____ | X _____ | X _____ | X _____ | X _____ | X _____ | X _____ |
| Downhill | _____ X _____ | _____ X _____ | _____ X _____ | _____ X _____ | _____ X _____ | _____ X _____ | _____ X _____ | _____ X _____ | _____ X _____ | _____ X _____ | _____ X _____ |

Combined Automobile & Heavy Truck DNL

Road No. 1 _____ Road No. 2 _____ Road No. 3 _____ Road No. 4 _____ Total DNL for All Roads _____

Signature _____ Date _____

List All Railways within 3000 feet of the site:

- 1. _____
- 2. _____
- 3. _____

Necessary information:

Railway No. 1 Railway No. 2 Railway No. 3

- 1. Distance in feet from the NAL to the railway track: _____
- 2. Number of trains in 24 hours:
 - a. diesel _____
 - b. electrified _____
- 3. Fraction of operations occurring at night (10 p.m. – 7 a.m.): _____
- 4. Number of diesel locomotives per train: _____
- 5. Number of rail cars per train:
 - a. diesel trains _____
 - b. electrified trains _____
- 6. Average train speed: _____
- 7. Is track welded or bolted? _____
- 8. Are whistles or horns required for grade crossings? _____

Adjustments for Diesel Locomotives

| | 9 No. of Locomotives 2 | 10 Average Speed Table 9 | 11 Horns (enter 10) | 12 Night- time Table 5 | 13 No. of Trains (line 2a) | 14 Adj. No. of Opns. | 15 DNL Workchart 3 | 16 Barrier Attn. | 17 Partial DNL |
|---------------|---------------------------------|-----------------------------------|---------------------------|---------------------------------|-------------------------------------|----------------------------|--------------------------|------------------------|----------------------|
| Railway No. 1 | X | X | X | X | X | = | - | = | |
| Railway No. 2 | X | X | X | X | X | = | - | = | |
| Railway No. 3 | X | X | X | X | X | = | - | = | |

Adjustments for Railway Cars or Rapid Transit Trains

| | 18 Number of cars 50 | 19 Average Speed Table 10 | 20 Bolted Rails (enter 4) | 21 Night- time Table 5 | 22 No. of Trains (Line 2a or 2b) | 23 Adj. No. of Opns. | 24 DNL Work- chart 4 | 25 Barrier Attn. | 26 Partial DNL |
|---------------|-------------------------------|------------------------------------|------------------------------------|---------------------------------|---|----------------------------|-------------------------------|------------------------|----------------------|
| Railway No. 1 | X | X | X | X | X | = | - | = | |
| Railway No. 2 | X | X | X | X | X | = | - | = | |
| Railway No. 3 | X | X | X | X | X | = | - | = | |

Combined Locomotive and Railway Car DNL

Railway No. 1 _____ Railway No. 2 _____ Railway No. 3 _____ Total DNL for all Railways _____

Signature _____

Date _____

Chapter 6
A Workbook for the Noise
Assessment Guidelines

Introduction

The following problems were prepared to give you the opportunity to practice the calculations and procedures described in the *Noise Assessment Guidelines*. Because it is so rarely used, we have not included any problems dealing with the aircraft noise procedure.

We have not reproduced the charts or tables from the *Guidelines* so you will need to have it at hand to do the problems.

Noise Assessment Guidelines Workbook

Problems

Problems 1 Through 7: Combining Sound Levels in Decibels

Calculate the Combined Sound Level for the Following Sets of Individual Levels:

- | | | |
|---|---|---|
| 1. 67 LDN 61 LDN _____ Combined Level | 2. 63 LDN 63 LDN _____ Combined Level | 3. 51 LDN 68 LDN _____ Combined Level |
| 4. 62 LDN 65 LDN _____ Combined Level | 5. 67 LDN 72 LDN _____ Combined Level | 6. 59 LDN 63 LDN 71 LDN _____ Combined Level |
| 7. 73 LDN 72 LDN 61 LDN 67 LDN _____ Combined Level | | |

Problems 8 and 9: Calculating Effective Distance

Calculate the Effective Distances for the Following Roads:

- | | | |
|----|---|-----------------------------|
| 8. | Distance in Feet from NAL to: Near Edge of Nearest Lane Far Edge of Farthest Lane Effective Distance | 22 Feet 76 Feet _____ |
| 9. | Distance in Feet from NAL to: Near Edge of Nearest Lane Far Edge of Farthest Lane Effective Distance | 60 Feet 84 Feet _____ |

Problems 10 Through 15: Adjustment Factors

List The Adjustment Factors Necessary for Each of the Following Situations and the Numerical Value for Each Adjustment Factor:

10. A Roadway Where the Road Gradient is 1%, the Average Speed for Both Autos and Trucks is 30 MPH and the Fraction of Nighttime Traffic is 10%.

Adjustment Factors Needed: _____

Value of Adjustment Factors: _____

11. A Roadway Where There is A Stop Sign 400 Feet from the NAL. The Gradient is 1%, the Average Speed for Autos is 45 MPH (There Are No Trucks) and the Fraction of Nighttime Traffic is 15%.

Adjustment Factors Needed: _____

Value of Adjustment Factors: _____

12. A Roadway Where the Road Gradient is 2%, the Average Speed for Autos is 50 MPH and for Trucks (Both Uphill and Downhill) is 50 MPH and the Fraction of Nighttime Traffic is 10%.

Adjustment Factors Needed: _____

Value of Adjustment Factors: _____

13. A Railroad Where the Fraction of Operations Occurring at Night is 30%, the Average Train Speed is 40 MPH, the Track is Bolted and There Are No Whistle Or Horns Required for Grade Crossings.

Adjustment Factors Needed: _____

Value of Adjustment Factors: _____

14. A Railroad Where the Fraction of Operations Occurring at Night is 5%, the Average Train Speed is 10 MPH, the Tracks Are Welded and There Are No Whistles Or Horns Required for Grade Crossing.

Adjustment Factors Needed: _____

Value of Adjustment Factors: _____

15. A Railroad Where the Fraction of Operations Occurring at Night is 20%, the Average Train Speed is 30 MPH, the Track is Bolted and No Whistles or Horns Are Required for Grade Crossings.

Adjustment Factors Needed: _____

Value of Adjustment Factors: _____

Problems 16 Through 21: Some Basic Problems

Calculate the Combined Noise Levels for Each of the Following Situations:

16. A Roadway Where the distance in Feet from the NAL to the Near Edge of the Nearest Lane is 310 Feet, the Distance to the Far Edge of the Farthest Lane is 358 Feet. There is A Stop Sign 400 Feet from the NAL. The Gradient is 1%. The Average Number of Automobiles is 17,000, the 24 Hour Average Number of Medium Trucks is 1,500, the 24 Hour Average Number of Heavy Trucks is 400 Total. The Fraction of Nighttime Traffic is 20%.

The Combined Noise Level for This Roadway is _____

17. A Site Exposed to Noise from Two Roads. For Roadway Number 1 the Distance in Feet from the NAL to the Near Edge of the Nearest Lane is 125 Feet, the Distance to the Far Edge of the Farthest Lane is 233 Feet. There is A Stop Sign 250 Feet from the NAL. The Gradient is 3%. The Average Speed for Both Autos and Trucks is 30 MPH.

The 24 Hour Average Number of Autos is 22,000, the 24 Hour Average Number of Medium Trucks is 2,000. The 24 Hour Average Number of Heavy Trucks is 950 Total. The Fraction of Nighttime Traffic is 10%.

For Roadway Number 2, the Distance to the Near Edge of the Nearest Lane is 45 Feet, the Distance to the Far Edge of the Farthest Lane is 93 Feet. There is A Stop Sign 100 Feet from the NAL and the Gradient is 1%. The Average Speed for Both Autos and Heavy Trucks is 30 MPH. The 24 Hour Average Number of Automobiles is 14,000, for Medium Trucks 700, and for Heavy Trucks 600 Total. The Fraction of Nighttime Traffic is 20%.

The Combined Noise Level for This Site is _____

18. A Site Exposed to Noise from Two Railroads. For Railroad 1, the Distance in Feet from the NAL to the Railway Track is 150 Feet. There Are 35 Diesel Trains Every 24 Hours, No Electrified Trains. The Fraction of Operations Occurring at Night is 25%. There Are 3 Diesel Locomotives Per Train and 70 Cars Per Train. The Average Speed is 30 MPH and the Track is Bolted. No Whistles Or Horns Are Used.

For Railroad 2, the Distance in Feet from the NAL to the Railway Track is 310 Feet. There Are 20 Diesel and 2 Electrified Trains Each 24 Hours. The Fraction of Operations Occurring at Night is 15%. There Are 2 Locomotives Per Diesel Train and 45 Cars for Each Diesel Train and 15 Cars Per Electrified Train. The Average Train Speed is 40 MPH and the Track is Bolted. No Horns Or Whistles Are Used.

The Combined Noise Level for This Site is _____

19. A Site Exposed to Noise from Two Railroads. For Railroad 1, the Distance in Feet from the NAL to the Railway Track is 75 Feet. There Are 34 Diesel Trains Every 24 Hours, No Electrified Trains. Twenty Percent of the Operations Occur at Night. There Are 5 Locomotives Per Train and 75 Cars Per Train. The Average Train Speed is 35 MPH and the Track is Welded. No Horns Or Whistles.

For Railway 2, the Distance in Feet from the NAL to the Railway Track is 120 Feet. There Are 12 Diesel Trains in 24 Hours, No Electrified Trains. Twenty-Five Percent of the Operations Occur at Night. There Are 4 Locomotives Per Train and 40 Cars Per Train. The Average Train Speed is 20 MPH and the Track is Bolted. No Horns Or Whistles Are Used.

The Combined Noise Level for This Site is _____

20. A Site Exposed to Noise from Three Roads. For Road 1, the Distance in Feet from the NAL to the Near Edge of the Nearest Lane is 100 Feet, to the Far Edge of the Farthest Lane, 208 Feet. There is No Stop Sign and the Gradient is 1%. The Average Speed for Autos is 55 MPH. (There Are No Trucks Allowed On This Road.) The 24 Hour Average Number of Autos is 40,000. The Fraction of Nighttime Traffic is 15%.

For Road 2, the Distance from the NAL to the Near Edge of the Nearest Lane is 45 Feet, to the Far Edge of the Farthest Lane 75 Feet. There is A Stop Sign 175 Feet from the NAL and the Road Gradient is 4%. The average Speed for Both Autos and Trucks is 40 MPH. The 24 Hour Average Number of Autos is 15,000, for Medium Trucks 900 and for Heavy Trucks 320 Total. The Fraction of Nighttime Traffic is 20%.

For Road 3, the Distance from the NAL to the Near Edge of the Nearest Lane is 52 Feet, to the Far Edge of the Farthest Lane 92 Feet. There is A Stop Sign 400 Feet from the NAL and the Gradient is 1%. The Average Speed for Both Autos and Trucks is 25 MPH. The 24 Hour Average Number of Autos is 5,000, for Medium Trucks 1,050 and for Heavy Trucks 175 Total. The Fraction of Nighttime Traffic is 20%.

The Combined Noise Level for This Site is _____

21. A Site Exposed to Noise from A Railroad. The Distance from the NAL to the Railroad is 110 Feet. There Are 30 Diesel Trains Every 24 Hours, No Electrified Trains. Twenty Percent of the Operations Occur at Night. There Are 3 Locomotives Per Train and 50 Cars Per Train. The Average Train Speed is 30 MPH, the Track is Bolted and There is A Grade Crossing Where Horns and Whistles Are Used 100 Feet from the NAL.

The Combined Noise Level at This Site is _____

Problems 22 Through 24: Barriers - Identifying the Values for H, R, R', D and D'

Identify the Values for H, R, R', D and D' for Each of the Following Barriers:

22.

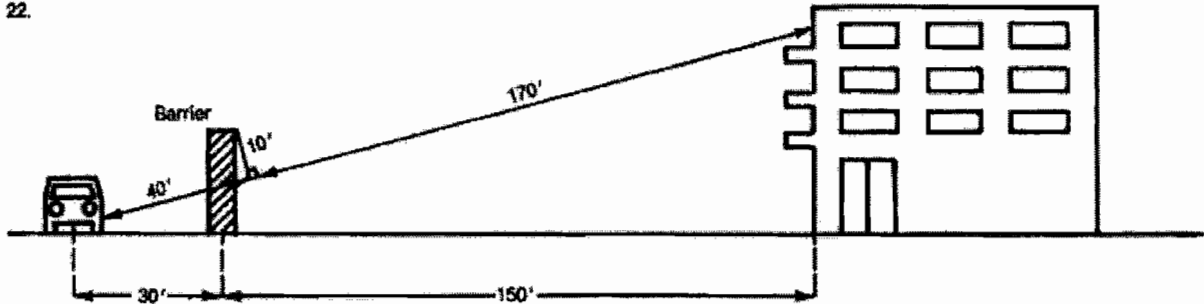

H = _____, R = _____, R' = _____, D = _____ and D' = _____

23.

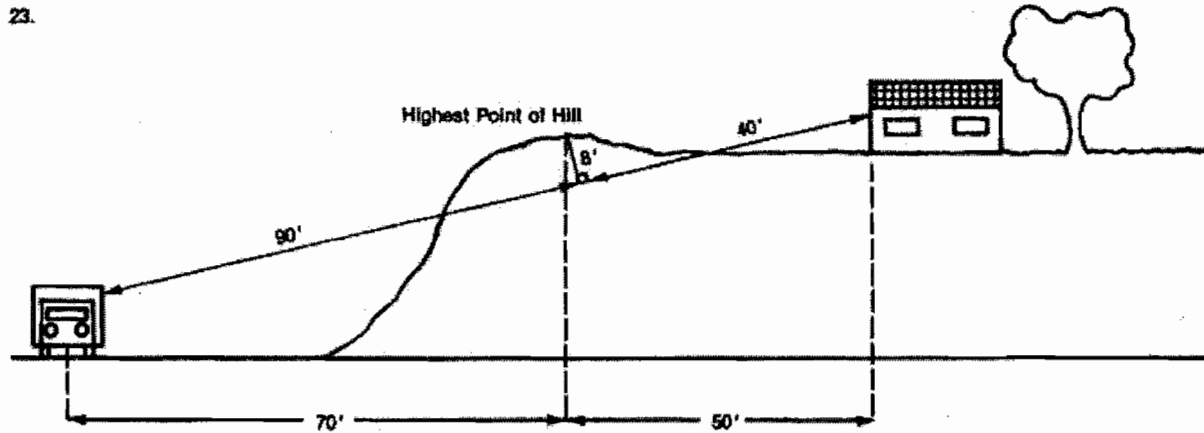

H = _____, R = _____, R' = _____, D = _____ and D' = _____

| | | | | | |
|-----------------------|-----|------|------|-----|-----|
| Barrier | 40' | 10' | 170' | 90' | 70' |
| Highest Point of Hill | 30' | 150' | | 8' | 50' |
| | | | | 40' | |

24.

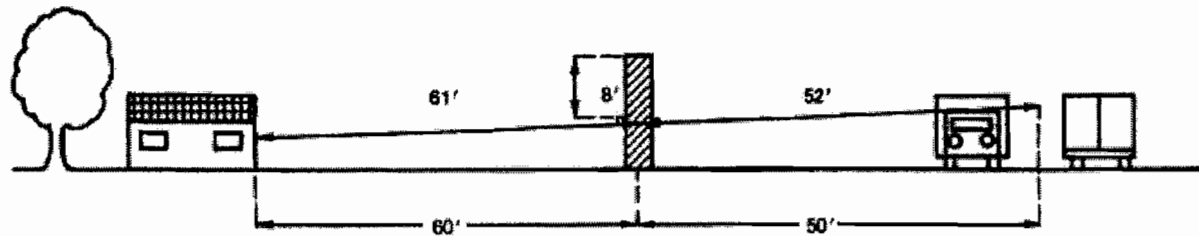

H = _____, R = _____, R' = _____, D = _____ and D' = _____

Problems 25 Through 27: Barrier Calculations Using Workcharts 6 and 7.

Using Workcharts 6 and 7 Only, Calculate the Noise Attenuation Provided by the Barriers Illustrated in Problems 22 Through 24. Additional Data on the Angles Subtended by the Ends of the Barriers and the NAL for Each Location is Provided.

25. Calculate the Noise Attenuation Provided by the Barrier Described in Problem 22. The Angle Subtended by the Ends of the Barrier and the NAL is 150 Degrees.

The Noise Attenuation Provided is _____ Decibels.

26. Calculate the Noise Attenuation Provided by the Barrier Described in Problem 23. The Angle Subtended by the Ends of the Barrier and the NAL is 90 Degrees.

The Noise Attenuation Provided is _____ Decibels.

27. Calculate the Noise Attenuation Provided by the Barrier Described in Problem 24. The Angle Subtended by the Ends of the Barrier and the NAL is 130 Degrees.

The Noise Attenuation Provided is _____ Decibels.

Problems 28 Through 30: Barrier Calculations Using Workcharts 5, 6 and 7

Calculate the Attenuation Provided By the Barriers in the Following Situations. Use Workcharts 5, 6 and 7.

28. A Two Story Building is Exposed to Noise Levels of 68 LDN from Automobiles. The Barrier is 15 Feet High and is Located 40 Feet from the Source and 20 Feet from the Building. The Source, Barrier, and Building are All on Level Ground. The Angle Subtended by the Ends of the Barrier and the Noise Assessment Location is 110 Degrees.

The Noise Attenuation Provided by This Barrier is _____ Decibels.

Is This Sufficient? _____

29. A Three Story Building is Exposed to a Noise Level of 72 LDN from Diesel Locomotives and 60 LDN from Railroad Cars. The Barrier is 12 Feet High and is Located 40 Feet from the Source and 85 Feet from the Building. The Barrier and the Building are on the Same Level, But the Track is Depressed 25 Feet. The Angle Subtended by the Ends of the Barrier and the NAL is 120 Degrees.

The Noise Attenuation Provided by This Barrier is _____ Decibels.

Is This Sufficient? _____

30. A Three Story Building is Exposed to Noise Levels of 67 LDN from Automobiles and 71 LDN from Trucks. The Barrier is 16 Feet High and is Located 36 Feet from the Source and 56 Feet from the Building. The Source, the Barrier and the Building are All at the Same Level. The Angle Subtended by the Barrier Ends and the NAL is 130 Degrees.

The Noise Attenuation Provided by This Barrier is _____ Decibels.

Is This Sufficient? _____

Noise Assessment Guidelines Workbook

Answers

Problem

1. 68 LDN (67-61 = 6, Add 1dB (From Table) to 67 = 68 LDN)
2. 66 LDN (63-63 = 0, Add 3dB (From Table) to 63 = 66 LDN)
3. 69 LDN (69-51 = 0, Add 0dB to 69 = 69 LDN)
4. 67 LDN (65-62 = 3, Add 1.8dB to 65, Round Off to Nearest Whole Number, 66.8 = 67 LDN)
5. 73 LDN (72-65 = 5, Add 1.2 = 73.2 = 73 LDN)
6. 72 LDN (63-59 = 4, Add 1.5 = 64.5, 71-64.5 = 6.5
Interpolate From Table: 6 = 1.0, 7 = .8
6.5 = .9) 71 + .9 = 71.9 = 72 LDN)

7. 76 LDN (67-61 = 6, Add 1.0 = 68, 72-68 = 4, Add 1.5 = 73.5,
73.5-73 = .5, Interpolate From Table,
Add 2.75 = 76.25 = 76 LDN)

8. 49 Feet (76 + 22 = 98 - 2 = 49)
9. 72 Feet (84 + 60 = 144 - 2 = 72)

10. Adjustment Factors Needed: Speed and Night-Time Percentage

Value of Factors: Speed = Autos .30
Trucks .81
Nighttime
Percentage .81

Note—You Must Have Different Speed Adjustments for Autos and Trucks.

11. Adjustment Factors Needed: Speed and Stop and Go Traffic

Value of Factors: Speed .87
Stop and Go .70

12. Adjustment Factors Needed: Gradient, Speed and Nighttime Percentage

Value of Factors: Gradient 1.4
Speed = Autos .30
Trucks .81
Nighttime
Percentage .81

13. Adjustment Factors Needed: Nighttime Percentage, Speed, Bolted Track

Value of Factors: Nighttime
Percentage 1.57
Speed = Engines .75
Cars 1.78
Bolted Track 4

Note—You Must Have Different Speed Adjustments for Engines and Cars.

14. Adjustment Factors Needed: Nighttime Percentage and Speed

Value of Factors: Nighttime
Percentage .82
Speed = Engines 3.0
Cars .11

15. Adjustment Factors Needed: Nighttime Percentage and Bolted Track

Value of Factors: Nighttime
Percentage 1.19
Bolted Track 4

16. Combined Noise Level = 62 LDN (If Your Answer Is Plus or Minus 1dB Its OK - Between Rounding Off and the Large Scale on the Nomographs, That's Close Enough)

Worksheet C
Roadway Noise
Page 1
Noise Assessment Worksheet

List all major roads within 1000' of the site

1. _____
2. _____
3. _____
4. _____

Necessary Information

| | Road 1 | Road 2 | Road 3 | Road 4 |
|---|--------|--------|--------|--------|
| 1. Distance in feet from the NAC to the edge of the road | | | | |
| A. nearest lane | 310 | | | |
| B. farthest lane | 358 | | | |
| C. average effective distance | 334 | | | |
| 2. Distance to stop sign | 400 | | | |
| 3. Road gradient in percent | 1% | | | |
| 4. Average speed in mph | | | | |
| a. Automobile | 40 | | | |
| b. Heavy Trucks - light | 40 | | | |
| c. Heavy Trucks - diesel | 40 | | | |
| 5. 24 hour average number of automobiles and medium trucks in both directions (ADT) | | | | |
| a. Automobile | 17000 | | | |
| b. medium trucks | 1500 | | | |
| c. effective ADT (a + 1/2b) | 32000 | | | |
| 6. 24 hour average number of heavy trucks | | | | |
| a. light | 200 | | | |
| b. diesel | 200 | | | |
| c. total | 400 | | | |
| 7. Fraction of night-time traffic (10:00 p.m. to 7:00 a.m.) | 20% | | | |
| 8. Traffic projected for what year? | | | | |

Worksheet C
Roadway Noise
Page 2
Noise Assessment Worksheet

Adjustments for Automobile Traffic

| | 10 | 11 | 12 | 13 | 14 | 15 | 16 | |
|------------|-----|-----|------|-------|-------|-----|-----|-----|
| | ADT | ADT | ADT | ADT | ADT | ADT | ADT | |
| Road No. 1 | .70 | .63 | 1.19 | 32000 | 14120 | 67 | 0 | .67 |
| Road No. 2 | | | | | | | | |
| Road No. 3 | | | | | | | | |
| Road No. 4 | | | | | | | | |

Adjustments for Heavy Truck Traffic

| | 17 | 18 | 19 | 20 | 21 | 22 | 23 | 24 | 25 |
|------------|-----|-----|-----|-----|-----|-----|-----|-----|-----|
| | ADT | ADT | ADT | ADT | ADT | ADT | ADT | ADT | ADT |
| Road No. 1 | | | | | | | | | |
| Road No. 2 | | | | | | | | | |
| Road No. 3 | | | | | | | | | |
| Road No. 4 | | | | | | | | | |

Combined Automobile & Heavy Truck ADT

Road No. 1: 62 Road No. 2: _____ Road No. 3: _____ Road No. 4: _____ Total ADT for All Roads: 62

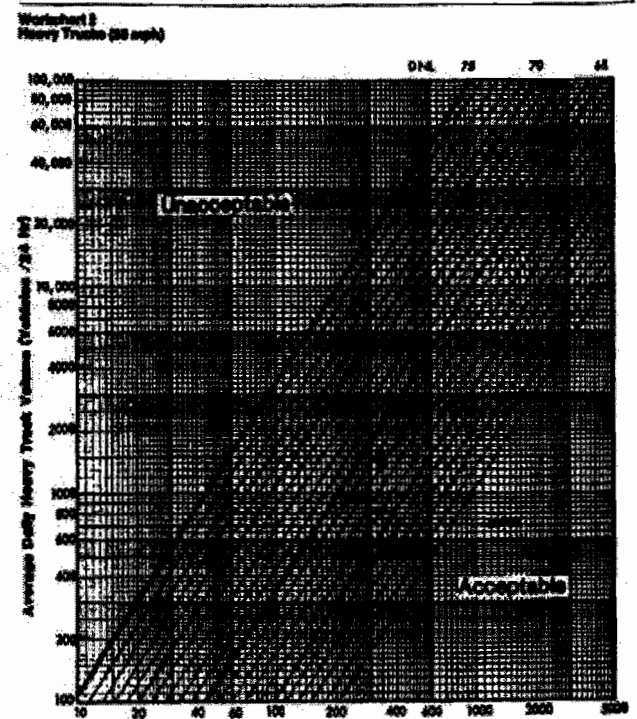
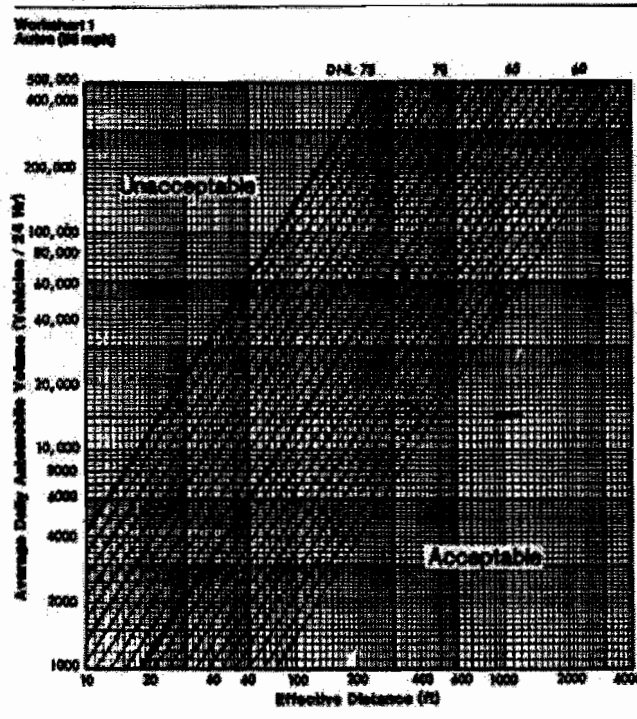

17. Combined Noise Level = 74 LDN (+ OR - 1 dB)

Worksheet C
Roadway Noise
Page 1
Noise Assessment Worksheet

List all major roads within 1000 ft of the site.

1. _____
2. _____
3. _____
4. _____

Necessary Information:

| | Road 1 | Road 2 | Road 3 | Road 4 |
|---|--------|--------|--------|--------|
| 1. Distance to road from the ARB to the edge of the road | | | | |
| a. receiver side | 125 | 45 | | |
| b. sender side | 232 | 93 | | |
| 2. average effective distance | 179 | 69 | | |
| 3. Distance to stop sign | 250 | 100 | | |
| 4. Road gradient % ascent | 2% | 1% | | |
| 5. Average speed in mph | | | | |
| a. Automobiles | 30 | 30 | | |
| b. Artery traffic - urban | 30 | 30 | | |
| c. Heavy Trucks - Interstates | 30 | 30 | | |
| 6. 24 hour average number of automobiles and medium trucks in both directions (ADT) | | | | |
| a. automobiles | 22000 | 16000 | | |
| b. medium trucks | 2000 | 700 | | |
| c. effective ADT (a + 1000b) | 42000 | 23000 | | |
| 7. 24 hour average number of heavy trucks | | | | |
| a. urban | 475 | 300 | | |
| b. arterial | 475 | 300 | | |
| c. I-95 | 980 | 600 | | |
| 8. Percentage of vehicles loaded (100% = all 70+ lbs) | 10% | 20% | | |
| 9. Traffic projected for what year? | | | | |

Worksheet C
Roadway Noise
Page 2
Noise Assessment Worksheet

Adjustments for Automobile Traffic:

| | 17 Day Traffic Type 1 | 18 Night Traffic Type 2 | 19 Edge Traffic Type 3 | 20 ADT (See 6c) | 21 Adjust ADT ADT | 22 DNL Worksheet 1 | 23 Grade Adjustment | 24 Final DNL |
|------------|--------------------------------|----------------------------------|---------------------------------|-----------------------|-------------------------|--------------------------|---------------------------|--------------------|
| Road No. 1 | 48 | 30 | 81 | 42000 | 4899 | 57 | 0 | 57 |
| Road No. 2 | 25 | 30 | 119 | 21000 | 1874 | 59 | 0 | 59 |
| Road No. 3 | | | | | | | | |
| Road No. 4 | | | | | | | | |

Adjustments for Heavy Truck Traffic:

| | 17 Day Traffic Type 1 | 18 Night Traffic Type 2 | 19 Edge Traffic Type 3 | 20 ADT (See 6c) | 21 Adjust ADT ADT | 22 DNL Worksheet 1 | 23 Grade Adjustment | 24 Final DNL |
|------------|--------------------------------|----------------------------------|---------------------------------|-----------------------|-------------------------|--------------------------|---------------------------|--------------------|
| Road No. 1 | 67 | 81 | 425 | 42000 | 1039 | 1.8 | 1.1515 | 68 |
| Road No. 2 | 81 | 425 | 385 | 21000 | 486 | 1.8 | 1.19 | 72 |
| Road No. 3 | | | | | | | | |
| Road No. 4 | | | | | | | | |

Combined Automobile & Heavy Truck DNL:

Road No. 1: 68 Road No. 2: 72 Road No. 3: Road No. 4: Total DNL for All Roads: 74

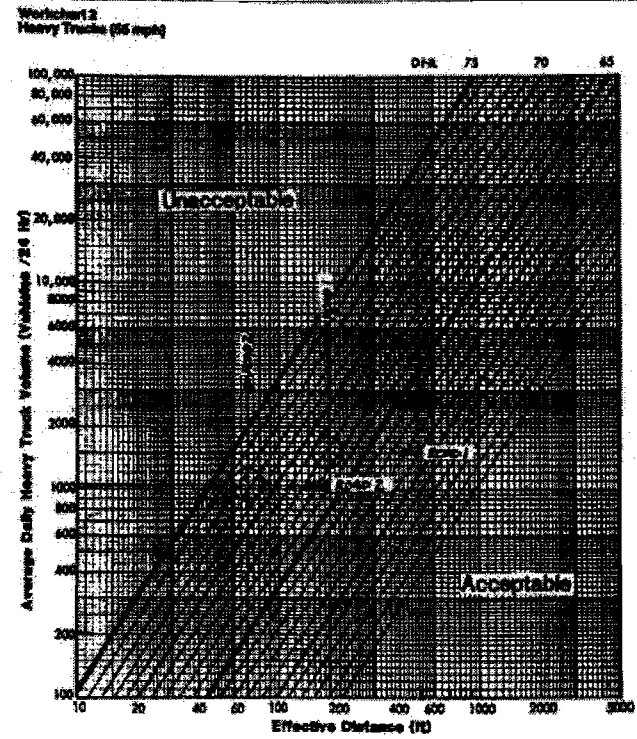
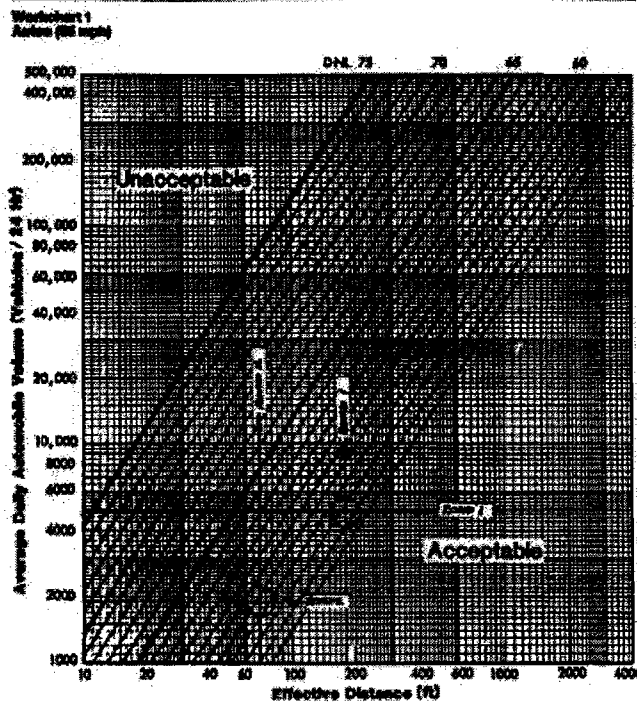

18. Combined Noise Level = 71 LDN

Note—in Order to Complete Column 18 for Railway #2 You Must Find the Average Number of Cars Per Train. Multiply the Number of Diesel Trains Times the Number of Cars Per Train (20 x 45 = 900). Multiply the Number of Electrified Trains Times the Number of Cars Per Train (2 x 15 = 30). Add the Two Totals Together and Divide By the Total Number of Trains (900 + 30 = 930 - 22 = 42).

| Worksheet D Railway Noise | | Page 2 | | Noise Assessment Subtotals | | | | | | | | | |
|--|-----------------------|-------------------|--------------------|----------------------------|------------------|----------------------------|-------------|-------------|-------------|-------------|-------------|--|--|
| Adjustments for Diesel Locomotives | | | | | | | | | | | | | |
| 10 | 11 | 12 | 13 | 14 | 15 | 16 | 17 | | | | | | |
| No. of Locomotives | Average Speed Table 9 | Hours (total hrs) | High-Speed Table 8 | No. of Trains (per hr) | Avg. No. of Cars | Eq. Weighting Factor | Sound Level | Sound Level | Sound Level | Sound Level | Partial DNL | | |
| Railway No. 1 | 1.6 | 1.0 | - | 1.30 | 35 | 72 | 70 | 0 | 72 | | | | |
| Railway No. 2 | 1 | .75 | - | 1.0 | 20 | 15 | 58 | 0 | 58 | | | | |
| Railway No. 3 | | | | | | | | | | | | | |
| Adjustments for Railway Cars on Single Track | | | | | | | | | | | | | |
| 18 | 19 | 20 | 21 | 22 | 23 | 24 | 25 | 26 | | | | | |
| Number of Cars | Average Speed Table 9 | Hours (total hr) | High-Speed Table 8 | No. of Trains (per hr) | Avg. No. of Cars | Eq. Weighting Factor | Sound Level | Sound Level | Sound Level | Sound Level | Partial DNL | | |
| Railway No. 1 | 1.4 | 1.0 | 4 | 1.35 | 35 | 270 | 64 | 0 | 64 | | | | |
| Railway No. 2 | .34 | 1.78 | 4 | 1.38 | 22 | 182 | 57 | 0 | 57 | | | | |
| Railway No. 3 | | | | | | | | | | | | | |
| Combined Locomotive and Railway Car DNL | | | | | | | | | | | | | |
| Railway No. 1 | 71 | Railway No. 2 | 61 | Railway No. 3 | 71 | Total DNL for all Railways | | | | | | | |

Signature _____ Date _____

19. Combined Noise Level = 76 LDN

| Worksheet D Railway Noise | | Page 2 | | Noise Assessment Subtotals | | | | | | | | | |
|--|-----------------------|-------------------|--------------------|----------------------------|------------------|----------------------------|-------------|-------------|-------------|-------------|-------------|--|--|
| Adjustments for Diesel Locomotives | | | | | | | | | | | | | |
| 10 | 11 | 12 | 13 | 14 | 15 | 16 | 17 | | | | | | |
| No. of Locomotives | Average Speed Table 9 | Hours (total hrs) | High-Speed Table 8 | No. of Trains (per hr) | Avg. No. of Cars | Eq. Weighting Factor | Sound Level | Sound Level | Sound Level | Sound Level | Partial DNL | | |
| Railway No. 1 | 2.5 | .82 | - | 1.19 | 34 | 89 | 75 | 0 | 75 | | | | |
| Railway No. 2 | 2 | 1.50 | - | 1.38 | 12 | 50 | 70 | 0 | 70 | | | | |
| Railway No. 3 | | | | | | | | | | | | | |
| Adjustments for Railway Cars on Single Track | | | | | | | | | | | | | |
| 18 | 19 | 20 | 21 | 22 | 23 | 24 | 25 | 26 | | | | | |
| Number of Cars | Average Speed Table 9 | Hours (total hr) | High-Speed Table 8 | No. of Trains (per hr) | Avg. No. of Cars | Eq. Weighting Factor | Sound Level | Sound Level | Sound Level | Sound Level | Partial DNL | | |
| Railway No. 1 | 1.5 | 1.29 | - | 1.19 | 34 | 84 | 63 | 0 | 63 | | | | |
| Railway No. 2 | .80 | .44 | 4 | 1.38 | 12 | 23 | 55 | 0 | 55 | | | | |
| Railway No. 3 | | | | | | | | | | | | | |
| Combined Locomotive and Railway Car DNL | | | | | | | | | | | | | |
| Railway No. 1 | 75 | Railway No. 2 | 70 | Railway No. 3 | | Total DNL for all Railways | | | | | | | |

Signature _____ Date _____

20. Combined Noise Level = 75 LDN

Worksheet C
Roadway Noise
Page 1
Noise Assessment Station

List of major roads within 1000 ft of site

1. _____
2. _____
3. _____
4. _____

Necessary Information

| | Road 1 | Road 2 | Road 3 | Road 4 |
|---|--------|--------|--------|--------|
| 1. Distance in feet from the R.M. to the edge of the road | | | | |
| a. constant line | 100 | 45 | 52 | |
| b. forward line | 302 | 75 | 92 | |
| c. average (effective) distance | 154 | 60 | 72 | |
| 2. Distance to stop sign | - | 175 | 400 | |
| 3. Road gradient in percent | 1% | 4.0% | 1% | |
| 4. Average speed in mph | | | | |
| a. Automobile | 65 | 40 | 25 | |
| b. heavy trucks - light | 55 | 40 | 25 | |
| c. heavy trucks - diesel | 55 | 40 | 25 | |
| 5. 24 hour average number of automobiles and medium trucks in both directions (ADT) | | | | |
| a. automobile | 4000 | 1500 | 500 | |
| b. medium trucks | - | 50 | 100 | |
| c. effective ADT (a + (b)(.1)) | 4000 | 1550 | 510 | |
| 6. 24 hour average number of heavy trucks | | | | |
| a. light | - | 160 | 27 | |
| b. diesel | - | 160 | 27 | |
| c. total | - | 320 | 54 | |
| 7. Percent of nighttime traffic (which runs in 7:00 AM) | 15% | 20% | 20% | |
| 8. Traffic projected for what year? | - | - | - | |

Worksheet C
Roadway Noise
Page 2
Noise Assessment Station

Adjustments for Automobile Traffic

| | 10 | 11 | 12 | 13 | 14 | 15 | 16 |
|------------|------|---------|-------|------|------|-----|-----|
| | Day | Evening | Night | ADT | ADT | ADT | ADT |
| | ADT | ADT | ADT | ADT | ADT | ADT | ADT |
| Road No. 1 | 4000 | 1500 | 500 | 4000 | 1500 | 500 | 67 |
| Road No. 2 | 3000 | 1000 | 300 | 3000 | 1000 | 300 | 65 |
| Road No. 3 | 1500 | 500 | 150 | 1500 | 500 | 150 | 60 |
| Road No. 4 | | | | | | | |

Adjustments for Heavy Truck Traffic

| | 17 | 18 | 19 | 20 | 21 | 22 | 23 | 24 | 25 | 26 | 27 |
|------------|-----|-----|-----|-----|-----|-----|-----|-----|-----|-----|-----|
| | ADT | ADT | ADT | ADT | ADT | ADT | ADT | ADT | ADT | ADT | ADT |
| Road No. 1 | 320 | 160 | 27 | 320 | 160 | 27 | 72 | 0 | 72 | | |
| Road No. 2 | 320 | 160 | 27 | 320 | 160 | 27 | 72 | 0 | 72 | | |
| Road No. 3 | 320 | 160 | 27 | 320 | 160 | 27 | 72 | 0 | 72 | | |
| Road No. 4 | | | | | | | | | | | |

Combined Automobile & Heavy Truck SPL

| Road No. 1 | Road No. 2 | Road No. 3 | Road No. 4 | Total SPL for All Roads |
|------------|------------|------------|------------|-------------------------|
| 67 | 73 | 68 | | 75 |

Signature _____ Date _____

21. Combined Noise Level = 81 LDN

To Solve This Problem You Must Add Some More Lines to the Workchart for Engines Because the Workchart as Set up Does Not Go High Enough. There Are A Variety of Ways to Do This But One of the Easiest Is to Take A Piece of Blank Paper (A 3 x 5 Card Does Very Well) Place the Edge of the Paper Along Either the Top Or Bottom Edge of the Workchart and Mark Where the LDN Lines Fall Along the Edge of the Blank Paper. Then Once You Have Drawn Your Distance and Operations Lines on the Work Chart, You Take Your Paper with the Line Markings and Lay It along the Line for Adjusted Operations with the Mark Farthest to the Right Lined up with the 75 LDN Line. Now Just Count over until You Reach the Intersection of the Operations and Distance Lines.

Worksheet 2
Railroad Noise

Page 2

Name Assessment Worksheet

Adjustments for Diesel Locomotives

| | 9 | 10 | 11 | 12 | 13 | 14 | 15 | 16 | 17 |
|---------------|--------------------|-----------------------|-----------------------|------------------------|---------------------|------------------|-----------------|-------------|-------------|
| | No. of Locomotives | Weight Rating Table 9 | Power Rating Table 10 | Length Rating Table 11 | No. of Cars Per Set | Adj. No. of Cars | DNL Worksheet 1 | Number Adj. | Partial DNL |
| Railway No. 1 | 15 | 1.0 | 10 | 1.19 | 30 | 535 | 81 | 0 | 81 |
| Railway No. 2 | | | | | | | | | |
| Railway No. 3 | | | | | | | | | |

Adjustments for Railway Cars or Rapid Transit Trains

| | 18 | 19 | 20 | 21 | 22 | 23 | 24 | 25 | 26 |
|---------------|----------------|------------------------|-----------------------|------------------------|-----------------------|------------------|-----------------|-------------|-------------|
| | Number of Cars | Weight Rating Table 18 | Power Rating Table 19 | Length Rating Table 20 | No. of Trains Per Set | Adj. No. of Cars | DNL Worksheet 2 | Number Adj. | Partial DNL |
| Railway No. 1 | 10 | 1.0 | 4 | 1.19 | 30 | 143 | 63 | 0 | 63 |
| Railway No. 2 | | | | | | | | | |
| Railway No. 3 | | | | | | | | | |

Combined Locomotives and Railway Car DNL

Railway No. 1 81 Railway No. 2 _____ Railway No. 3 _____ Total DNL Level of Railway 81

Signature _____ Date _____

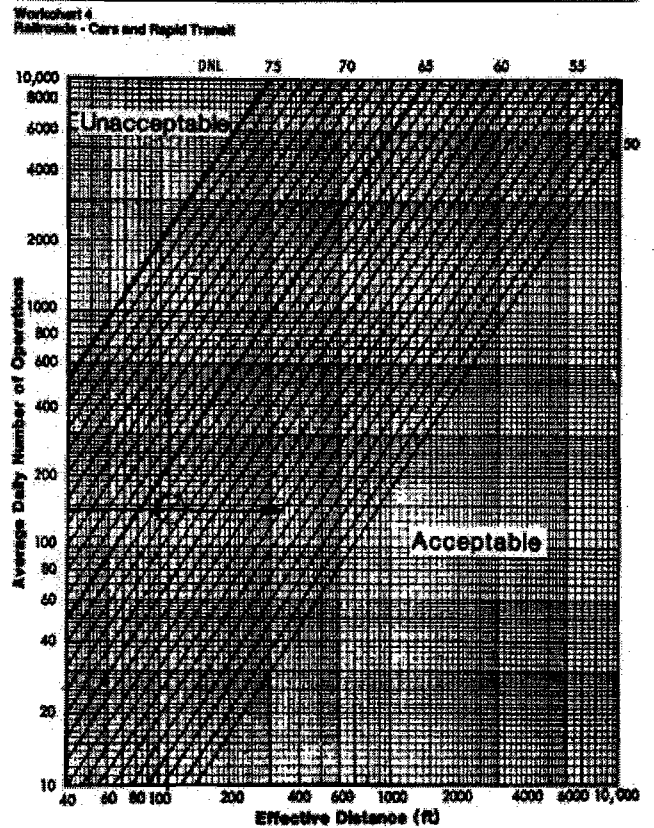
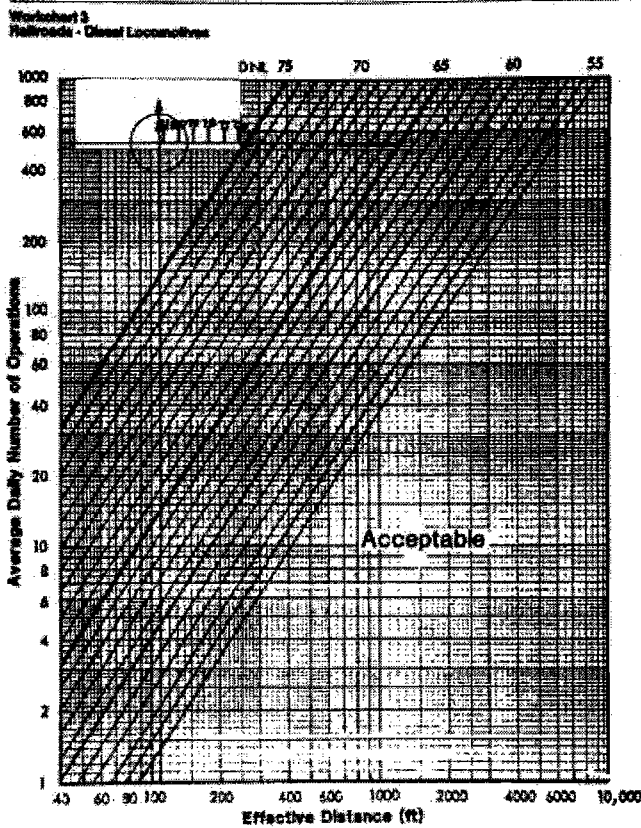

22. $H = 10$ Feet, $R = 40$ Feet, $R' = 30$ Feet, $D = 170$ Feet, $D' = 150$ Feet

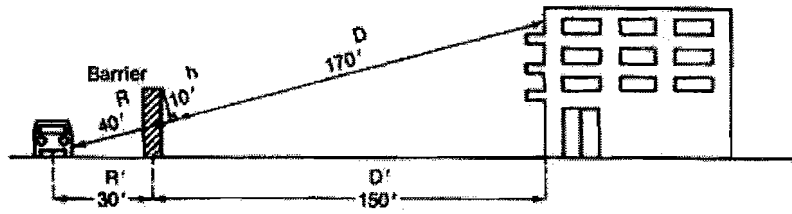

23. $H = 8$ Feet, $R = 90$ Feet, $R' = 70$ Feet, $D = 40$ Feet, $D' = 50$ Feet

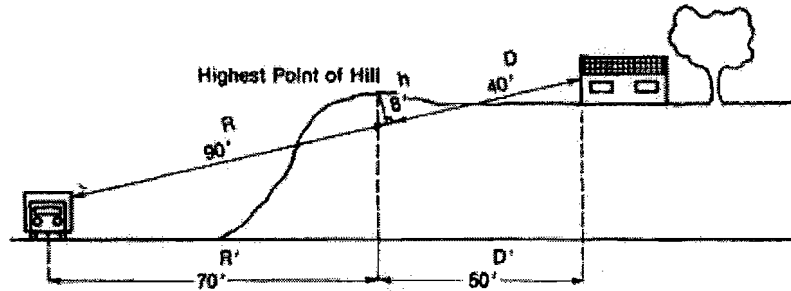

Note—The Line of Sight Starts Above the Road Level Because of the Trucks.

24. $H = 8$ Feet, $R = 52$ Feet, $R' = 50$ Feet, $D = 61$ Feet, $D' = 60$ Feet

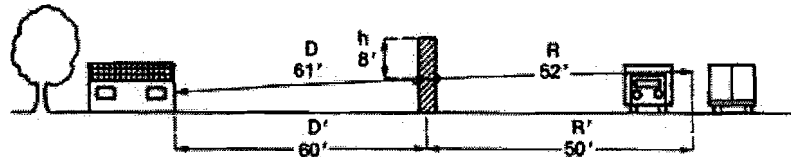

25. The Noise Attenuation Provided is 7 Decibels

Worksheet 6
Noise Barrier

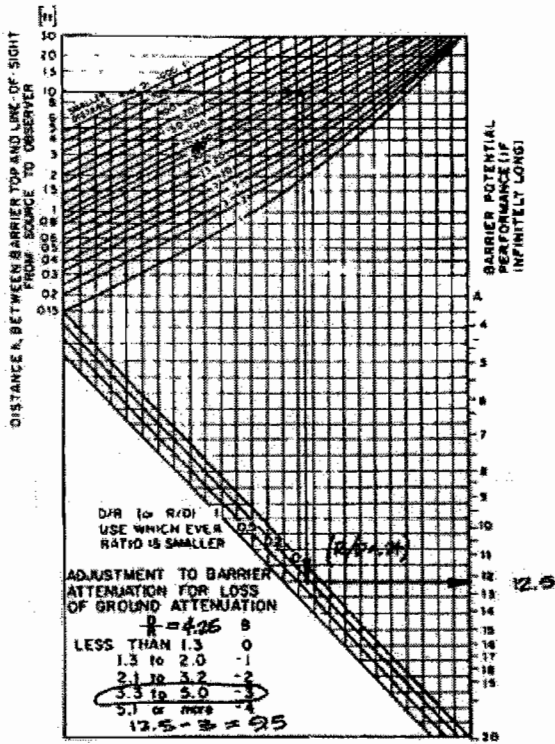

Worksheet 7

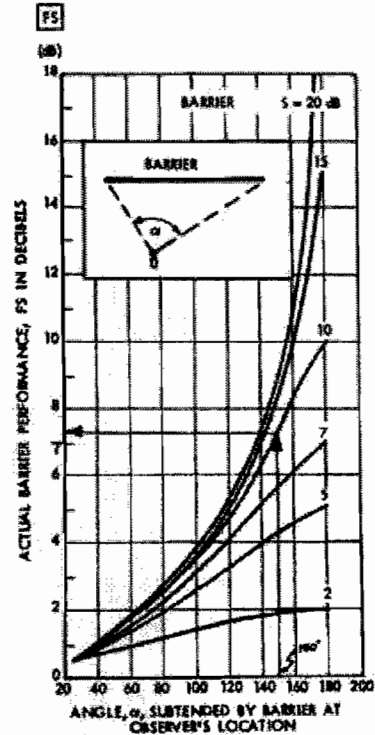

Correction factor applied to barrier potential in order to find the actual performance of the barrier of the same construction but of finite length.

26. The Noise Attenuation Provided Is 3 Decibels

Note—When the Curves Are So Close Together Don't Worry About Extrapolating. In This Case You Couldn't Anyway, the 15 dB and 10 dB Curves Have Merged.

Worksheet 6
Noise Barrier

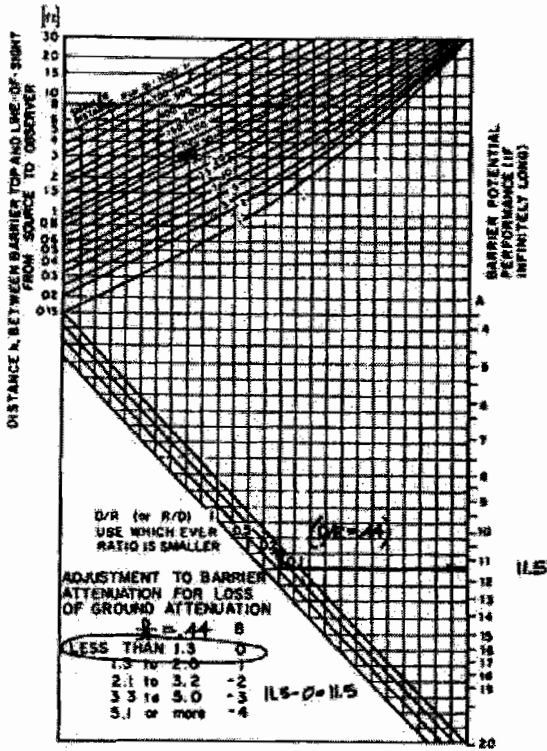

Worksheet 7

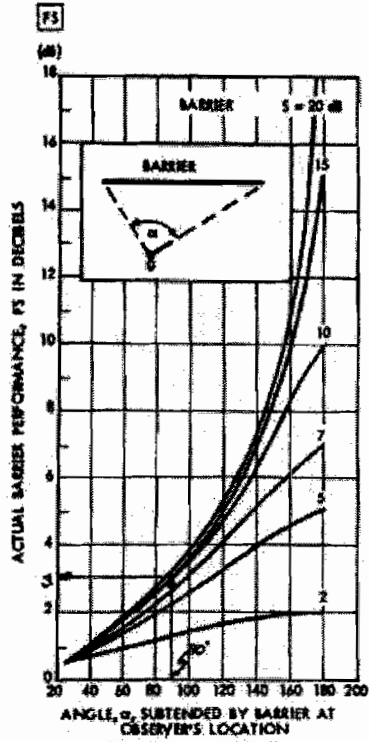

Corrections to be applied to barrier potential in order to find the actual performance of the barrier of the same construction but of finite length.

27. The Noise Attenuation Provided is 6 Decibels (5.5 Rounded Up)

Note—Again You Have Problems With Extrapolating—Don't Worry About Being Too Precise.

Workchart 6
Noise Barrier

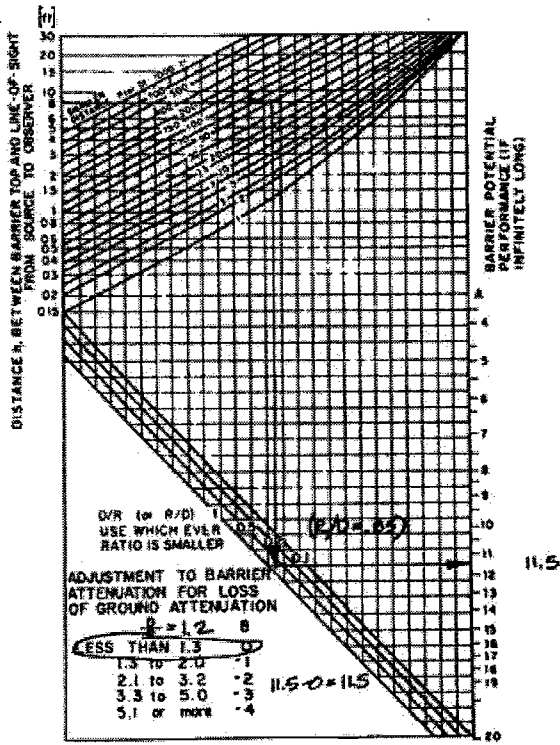

Workchart 7

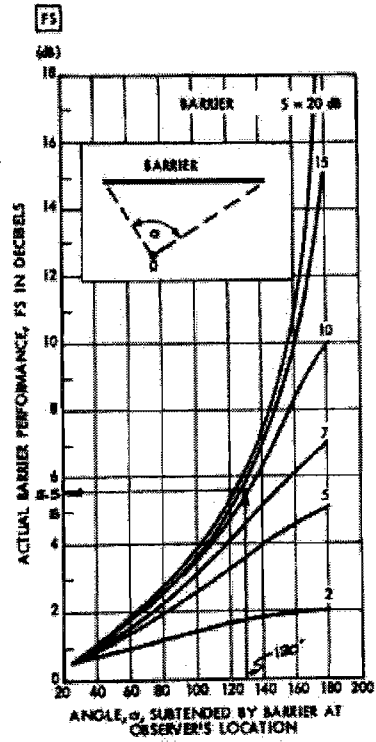

Correction to be applied to barrier potential in order to find the actual performance of the barrier of the same construction but of finite length.

28. The Noise Attenuation Provided by This Barrier is 4 dB. This is Sufficient

Note—Don't Forget That the Height of the observer is 5' Less Than the Total Height of the Building and the Height of the Building is 10 Feet Times the Number of Stories. And Did You Remember to Make the Adjustment for Ground Attenuation Loss.

Worksheet 6
Noise Barrier

To find A, B, C and D from the Dimensions and Distances

Fill out the following worksheet (all quantities are in feet)

Under the values for:

H = 15 W = 40
D = 0 D' = 20
O = 15

1. Elevation of barrier top above elevation of source: $[H \ 15] - [0 \ 0] = [15 \ 15]$
2. Elevation of observer above elevation of source: $[0 \ 15] - [0 \ 0] = [15 \ 15]$
3. Map distance between source and observer (R + D'): $[60 \ 60]$
4. Map distance between barrier and source (R): $[40 \ 40]$
5. Line 3 divided by line 4: $[15 \ 15] \div [40 \ 40] = [0.25 \ 0.25]$
6. Square the quantity on line 5 (i.e., multiply it by itself), always positive: $[0.25 \ 0.25] \times [0.25 \ 0.25] = [0.0625 \ 0.0625]$
7. 40% of line 6: $[0.0625 \ 0.0625] \times 0.4 = [0.025 \ 0.025]$
8. One minus line 7: $[1 \ 1] - [0.025 \ 0.025] = [0.975 \ 0.975]$
9. Line 5 times line 8 (will be negative if line 7 is negative): $[0.25 \ 0.25] \times [0.975 \ 0.975] = [0.24375 \ 0.24375]$
10. Line 1 minus line 9: $[15 \ 15] - [0.24375 \ 0.24375] = [14.75625 \ 14.75625]$
11. Line 10 times line 8: $[14.75625 \ 14.75625] \times [0.975 \ 0.975] = [14.3875 \ 14.3875]$
12. Line 8 times line 10: $[0.975 \ 0.975] \times [14.3875 \ 14.3875] = [13.9375 \ 13.9375]$
13. Line 4 divided by line 12: $[40 \ 40] \div [13.9375 \ 13.9375] = [2.87 \ 2.87]$
14. Line 13 plus line 12: $[13.9375 \ 13.9375] + [2.87 \ 2.87] = [16.8075 \ 16.8075]$
15. Line 3 minus line 14: $[60 \ 60] - [16.8075 \ 16.8075] = [43.1925 \ 43.1925]$
16. Line 15 divided by line 8: $[43.1925 \ 43.1925] \div [0.975 \ 0.975] = [44.3 \ 44.3]$
17. Line 16 minus line 12: $[44.3 \ 44.3] - [13.9375 \ 13.9375] = [30.3625 \ 30.3625]$

Circle the value on line 17 to be negative in Worksheet 7 and use the value on line 17, and the line 1 may also be negative. Remember, line 17 may also be negative. Remember, line 17 may also be negative. Remember, line 17 may also be negative.

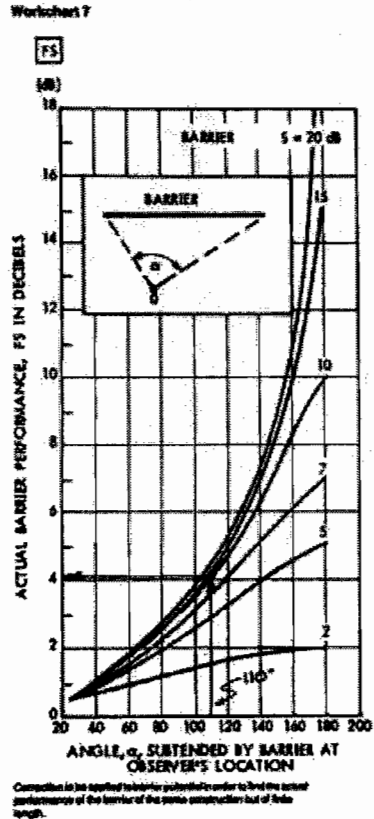
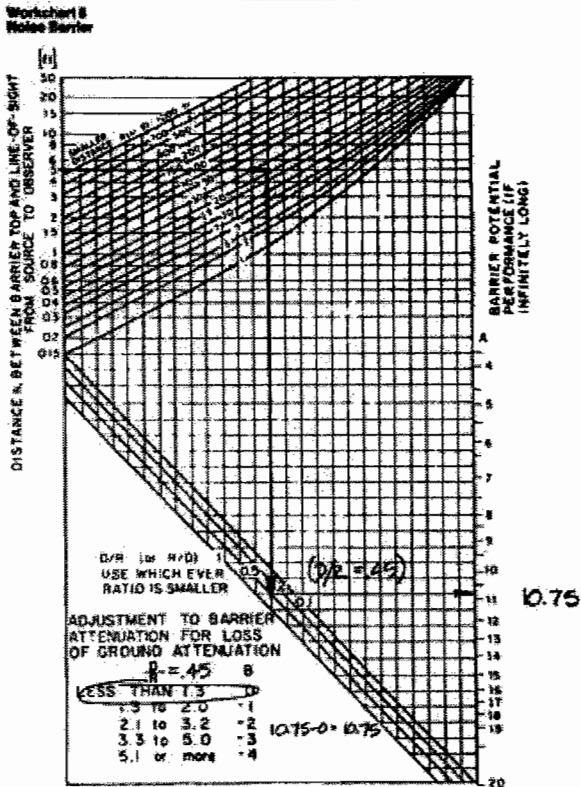

29. The Noise Attenuation Provided by This Barrier is Approximately 5 dB for Both the Engines and the Railroad Cars.

This Is Not Sufficient.

Note—You Were Supposed to Calculate Attenuation for Diesel Engines and Cars Separately Because the Source Heights Are Different. The Value of S for the Engines Should Have Been -10 and the Value of S for the Railroad Cars Should Have Been -25.

Worksheet 5
Noise Barrier

Enter the values for:

To Item 6, it uses the elevation and distance

Fill out the following worksheet (all quantities are in feet):

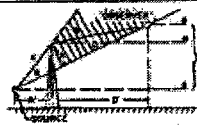

1. Elevation of barrier top minus elevation of source [12] - [-10] = [22]

2. Elevation of observer minus elevation of source [25] - [-10] = [35]

3. Map distance between source and observer (R + D) [125]

4. Map distance between barrier and source (R) [40]

5. Line 2 divided by line 3 [22] ÷ [35] = [.28]

6. Square the quantity on line 5 (i.e., multiply it by itself): always positive [.28] × [.28] = [.08]

7. 40% of line 6 [40] × [.08] = [.03]

8. One minus line 7 [1] - [.03] = [.97]

9. Line 5 times line 4 (add if negative; line 7 is negative) [.28] × [40] = [11.2]

10. Line 1 minus line 9 [22] - [11.2] = [10.8]

11. Line 10 times line 8 [10.8] × [.97] = [10.5] =

12. Line 3 times line 10 [125] × [10.5] = [1312.5]

13. Line 4 divided by line 9 [40] ÷ [.97] = [41]

14. Line 13 plus line 12 [41] + [1312.5] = [1353.5] =

15. Line 3 minus line 4 [125] - [40] = [85]

16. Line 15 divided by line 11 [85] ÷ [.97] = [88]

17. Line 16 minus line 12 [88] - [1312.5] = [-1224.5] =

Notes: Use values on line 11 and 17, that adding a negative number is the same as subtracting. Always use a positive number when adding a negative number to a positive number. Round all R and D to nearest integer, to two decimal places.

Worksheet 6
Noise Barrier

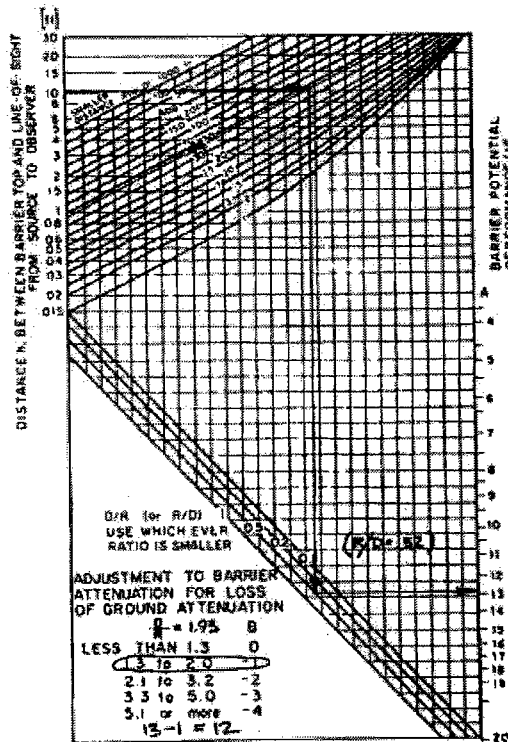

Worksheet 7

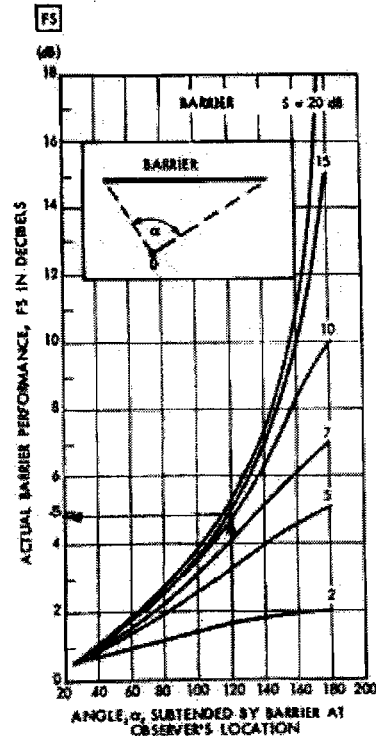

Correction to be applied to barrier potential in order to find the actual performance of the barrier of the same construction but of finite length.

Worksheet 5
Noise Barrier

To find A, B and C from the Dimensions and Distances

Enter the values for:

h = 12 a = 40
 b = -25 d = 85
 c = 25

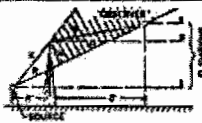

Fill out the following worksheet. All questions are to be used.

1. Elevation of barrier top minus elevation of source $[12] - [-25] = [37]$
2. Elevation of observer minus elevation of source $[25] - [-25] = [50]$
3. Map distance between source and observer (D) $[125]$
4. Map distance between barrier and source (R) $[40]$
5. Line 2 divided by line 3 $[50] \div [125] = [.4]$
6. Square the quantity on line 5 (i.e., multiply it by itself); always positive $[.4] \times [.4] = [.16]$
7. 80% of line 6 $[.16] \times [.8] = [.128]$
8. One minus line 7 $[1] - [.128] = [.872]$
9. Line 5 times line 4 (will be negative since 5 is negative) $[.4] \times [40] = [16]$
10. Line 1 minus line 9 $[37] - [16] = [21]$
11. Line 10 times line 8 $[21] \times [.872] = [18.312]$
12. Line 4 times line 10 $[40] \times [21] = [840]$
13. Line 4 divided by line 11 $[40] \div [18.312] = [2.184]$
14. Line 12 plus line 13 $[18.312] + [2.184] = [20.496]$
15. Line 3 minus line 4 $[125] - [40] = [85]$
16. Line 14 divided by line 15 $[20.496] \div [85] = [240.4]$
17. Line 16 minus line 12 $[240.4] - [840] = [-599.6]$

Notes: The values on line 2 may be negative. In such cases use the value of line 2, and 10. The 7 may also be negative. Remember, then, in line 9 that adding a negative number is the same as subtracting. A negative divided by a negative number is a positive. Round off A and B to nearest integer. Always include units.

Worksheet 6
Noise Barrier

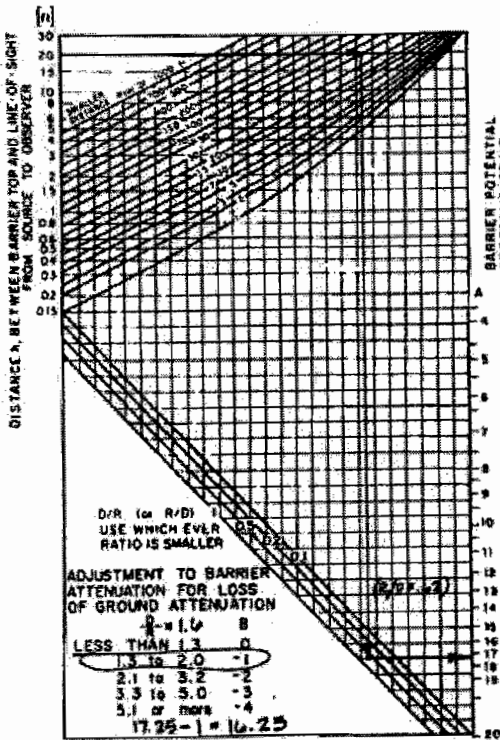

Worksheet 7

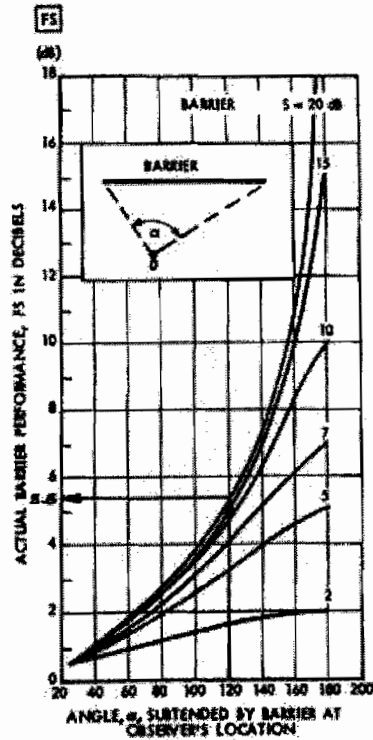

30. The Noise Attenuation Provided by This Barrier is 3 dB for Trucks and 5 dB for Autos. The Combined Level Resulting is 69 LDN.

This is Not Sufficient

Note—You Must Calculate the Barrier Effect Separately for Autos and Trucks Because the Source Height is Different. Then Recombine levels.

Worksheet 5
Noise Barrier

To find A, D and h from the following and Distance

Fill in the following numbers:
(All quantities are in feet)

Enter the values for:

h = 16 H = 36
 s = 0 D = 56
 Q = 25



- Direction of barrier minus elevation of source: $(H 16) - (0) = (16)$
- Elevation of observer minus elevation of source: $(25) - (0) = (25)$
- Map distance between source and observer (D - D): (92)
- Map distance between barrier and source (H): (36)
- Line 2 divided by line 3: $(16) \div (92) = (.27)$
- Square the quantity on line 5 (i.e., multiply by itself): $(.27) \times (.27) = (.07)$
- 40% of line 6: $(.07) \times .4 = (.03)$
- One minus line 7: $(1) - (.03) = (.97)$
- Line 5 times line 8 (or the negative of line 2 multiplied): $(.27) \times (.36) = (.97)$
- Line 1 minus line 8: $(16) - (.97) = (15.03)$
- Line 10 times line 9: $(15.03) \times (.97) = (14.58)$
- Line 2 times line 10: $(.27) \times (14.58) = (3.93)$
- Line 4 divided by line 9: $(36) \div (.97) = (37.11)$
- Line 10 plus line 11: $(14.58) + (37.11) = (51.69)$
- Line 9 minus line 4: $(.97) - (36) = (-35.03)$
- Line 10 divided by line 12: $(51.69) \div (-35.03) = (-1.47)$
- Line 10 minus line 13: $(51.69) - (-1.47) = (53.16)$

From lines 14, 15, and 17, determine a negative value for h in the final step.

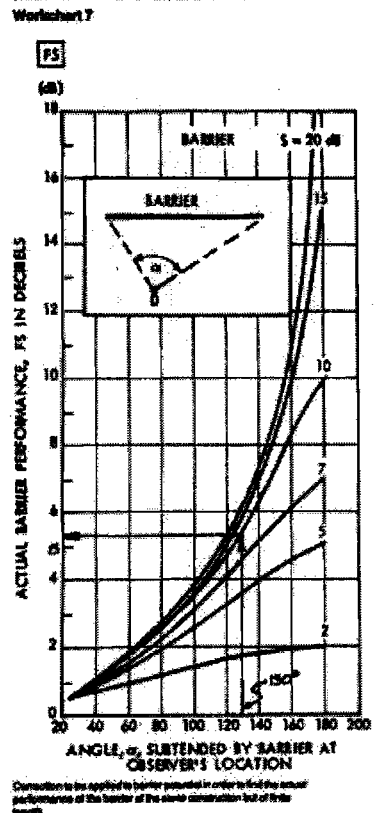
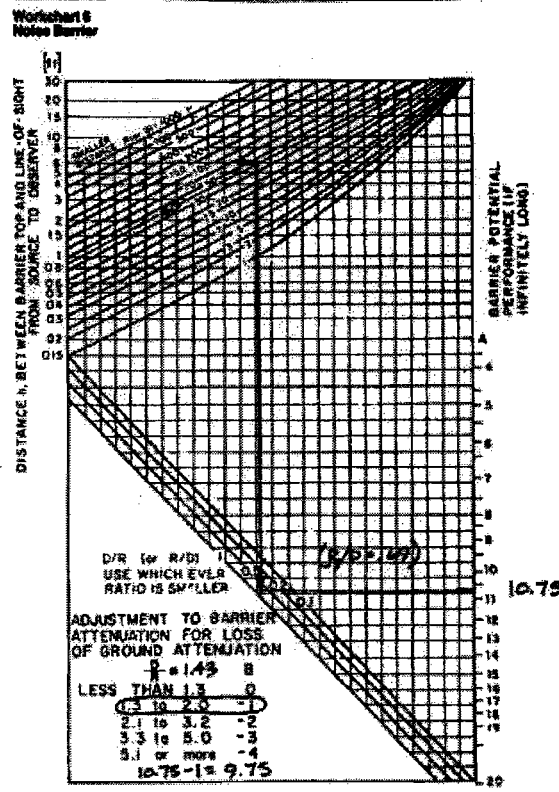

Worksheet 5
Noise Barrier

To find A, B, and C from Site Elevations and Distances

Enter the values for:

H = 16 h = 36
 S = 0 D = 56
 C = 25

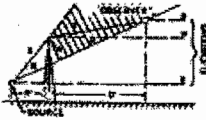

Fill out the following worksheet (all quantities are in feet)

1. Elevation of barrier top minus elevation of source [16] - [0] = [16]
2. Elevation of observer minus elevation of source [0] - [25] = [-25]
3. Map distance between source and observer (D - D')
4. Map distance between barrier and source (S)
5. Line 2 divided by line 3
6. Square the quantity on line 5 (i.e., multiply it by itself; always positive)
7. 40% of line 6
8. One minus line 7
9. Line 3 times line 8 (will be negative if line 2 is negative)
10. Line 1 minus line 9
11. Line 10 times line 8
12. Line 2 times line 10
13. Line 4 divided by line 8
14. Line 13 plus line 12
15. Line 3 minus line 4
16. Line 15 divided by line 8
17. Line 16 minus line 13

Enter the values on line 16 and 17, and adding if negative number to the same or subtracting if positive. If the result is negative, it means the barrier is not effective. If the result is positive, it means the barrier is effective. The value on line 16 is the barrier performance in dB. The value on line 17 is the barrier performance in dB per foot of barrier length.

Worksheet 6
Noise Barrier

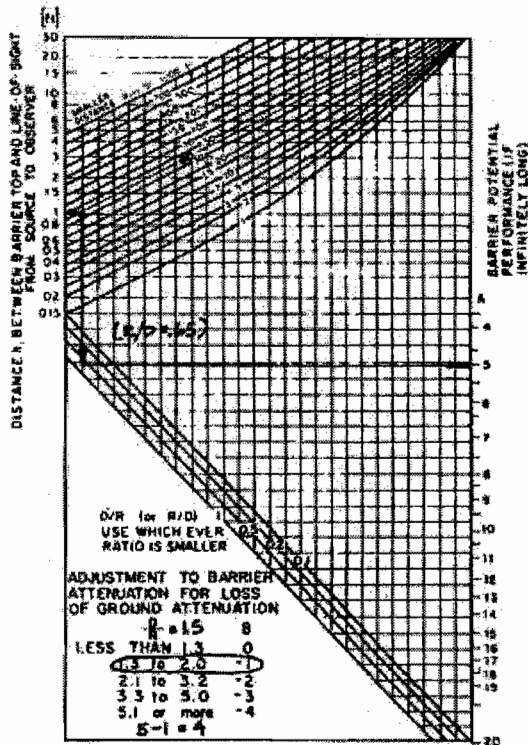

Worksheet 7

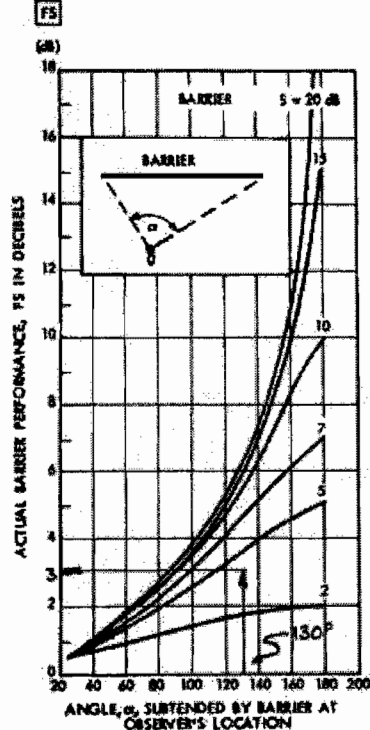

Correction to be applied to barrier potential in order to find the actual performance of the barrier of the same construction but of finite length.

Chapter 7

The Use of Noise Measurements

Noise Calculations Are Best For HUD Use

There are two ways to determine noise levels for a site under review: the noise can be calculated or it can be measured. While one's first reaction might well be that it would obviously be better to go out and actually measure the noise levels at the site, calculated noise levels are really much better for implementing HUD's noise policy.

Calculated noise levels are developed using mathematical models that contain a variety of assumptions about the process of noise propagation as well as data on sound levels generated by typical sources (i.e. aircraft engines, automobile tires etc.). The model can be a complex computer model or it can be a simple desktop model such as the procedures in the *Noise Assessment Guidelines*. The models can also employ a variety of noise descriptors. (See chapter 1 for a discussion of noise descriptors.) Most noise studies done for the Federal Highway Administration, for example, use either the L_{10} or the L_{eq} noise descriptor. Many aircraft noise studies use the NEF or CNEL descriptor. All of these descriptors are compatible with the L_{dn} noise descriptor system that is preferred by HUD and the HUD noise regulation contains instructions for converting all of them into L_{dn} (sections 51.106(a)(1) and (2))

Whether produced by a sophisticated computer model or by the desktop *Noise Assessment Guidelines*, calculated noise levels are more useful for HUD needs than measured levels for two significant reasons: The first is that with noise measurements you have no good way to take into account future changes in the future noise environment. The houses we help build today are going to be around for a long time and it is very important that we determine, to the extent we can, the noise environment that will exist throughout the life of the buildings.

While there are clearly limitations on how far into the future we can reasonably project traffic levels for roads, railroads and airports, we can at least look 5 to 10 years ahead. The HUD noise regulation (24 CFR 51B) requires that "to the extent possible, noise exposure shall be projected to be representative of conditions that are expected to exist at a time at least 10 years beyond the date of the project or action under review." It is very easy to make these projections if you use the *Noise Assessment Guidelines* or a computer model to determine noise levels.

The second reason why we prefer that you calculate noise levels is that through the calculation process you can use monthly or yearly data to determine traffic levels. Thus you come up with a more typical picture of conditions. With noise measurements there is always the possibility that the day or even days chosen for measurements will not be typical and that the measurements may over or understate the problem. While the conscientious measurer will try to account for any unusual conditions, it isn't always possible. So long as cost considerations limit the number of days that measurements can be taken there will always be the problem of unrepresentative data. With calculations this isn't a problem. The computer model that generates contours for airports, for example, uses an entire years data to develop the average day. Certainly the results are more likely to be representative than the results that would be derived from just a few days measurements.

When Noise Measurements Are Useful

While it is the preferred procedure to calculate noise levels, there are a few situations where the noise models might not be accurate and it might be better to rely on measurements. One instance would be when there is insufficient or inadequate traffic data. Another case might be where you have a unique physical situation that is not accounted for in whatever mathematical model is available.

Obtaining good traffic data can be difficult. You may only be able to get gross data that simply lists total vehicles without making any distinctions between trucks and automobiles. Or you may not be able to get any reliable data on the percentage of traffic between 10 pm and 7 am. While the *Noise Assessment Guidelines* do contain some assumptions that you can use when you don't have all the data you need, there may be instances when you just don't think those assumptions would accurately portray the problem.

By the same token, there are certain physical situations that mathematical models such as the *Noise Assessment Guidelines* couldn't anticipate and therefore do not reflect in their formulas. For example, the *Guidelines* say that you don't have to calculate the noise levels for underground transit lines. Well what if the line is underground but there are large air vents that reach from the belowground tunnels to the surface? A great deal of noise can reach the surface through these vents but the *Noise Assessment Guidelines* don't have any way to take it into account. You couldn't treat it as if the subway line were aboveground because it isn't really and at least some of the noise is blocked. This would be a case where a noise measurement would probably be the best way to determine the noise levels. By the same token, the guidelines do not really take into account the sometimes significant amounts of reflected noise that can occur at urban sites surrounded by tall buildings, i.e. the canyon effect.

When Not to Use Measurements

One thing noise measurements should not be used for is to confirm or refute calculated noise levels, especially computer generated aircraft contours. Our experience with both the *Noise Assessment Guidelines* and with computer noise models is that both are quite accurate if done properly. If you are convinced that the calculations were done correctly, and if you believe that the data used were good, you should strongly discourage anyone who wants to take measurements because they think that measurements are inherently more accurate than calculations. Comparing measured noise levels to calculated levels is like comparing apples and oranges. The

calculated noise levels should include projected traffic levels, the measured ones will not. The calculated levels will be based on daily traffic counts derived by averaging months of data, the measured levels will, at best, reflect just a few days. (This is particularly true for aircraft noise contours. The day-to-day operations of an airport can vary significantly depending upon weather conditions and any one or two days worth of measurements are very likely to show different levels from those generated by a computer model employing a year of data to derive an average day.)

If you have determined that noise measurements are appropriate, you must make sure that they are done properly, otherwise the data will be useless. There are four elements to proper measurements: 1) where the measurements are taken; 2) when they are taken; 3) the type of equipment used; and 4) the actual measurement procedure.

Where measurements should be taken: The locations for noise measurements should be selected using the same criteria you would use to select a Noise Assessment Location for a *Noise Assessment Guidelines* calculation. The *Noise Assessment Guidelines* recommend that "assessments of the noise exposure should be made at representative locations around the site where significant noise is expected." Further, the *Guidelines* state that when selecting these locations you should consider those buildings containing noise sensitive uses which are closest to the predominant noise sources. Where quiet outdoor space is desired at a site, you should also select points in the outdoor area in question. Specifically, the "relevant measurement location for buildings is a point 2 meters (6.5 feet) from the facade." If there are no buildings yet the measurement point should be 2 meters from the closest point setback requirements would allow a building facade.

When measurements should be taken: Because measurements are only going to be taken for a few days at best, special care should be taken to make sure that the days selected are representative of average traffic levels. For highways, avoid both Monday and Friday, particularly before or after a holiday. In fact holiday periods, such as the Christmas/New Years season, should be avoided entirely. Highway traffic, or rather more importantly, truck traffic is likely to be down during

these periods and noise levels may be significantly lower than normal. On the other hand, holiday periods are often peak travel periods for airlines and measurements taken around airports then would show unusually high noise levels.

Whoever is taking the measurements should also check to make sure that there aren't any special circumstances that might affect traffic levels. For example road construction or repair work might divert additional traffic onto the road being measured, or divert traffic away. In both cases the noise levels measured would not be representative.

And finally, noise measurements should not be taken during extreme weather conditions both because of the possible effects on traffic levels but also because the weather conditions can exaggerate the actual noise levels.

Ideally, noise measurements should be taken over several days, spread over at least a few months. But given that time and money will normally preclude this, at least make sure the one or two days you can get are as close to typical as possible.

What equipment to use: There are many sound level meters on the market which are suitable for taking noise measurements for transportation sources. They need only to meet the requirements of American National Standard Specification for Type 1 Sound Level Meters: S1.4-1971. Type 1 sound level meters are "precision" meters and provide the most accurate measurements. They are also, of course, the most expensive. Fast time-averaging and A frequency weighting are to be used. The sound level meter with the A-weighting is progressively less sensitive to sound with frequencies below 1,000 hertz, somewhat as is the ear. With fast time averaging the sound level meter responds particularly to recent sounds almost as quickly as does the ear in judging the loudness of a sound. Fast time averaging has a time constant of about 1/8 second.

While a sound level measuring system that averages decibel readouts on a short term basis such as for every minute or every hour is acceptable, it would be far better if a system that actually provides a 24 hour integrated L_{dn} readout were used. Such a system eliminates the need for calculating the L_{dn} value, an area where many inexperienced consultants go astray. These systems are more expensive however, and the

consultant who doesn't do much noise work is unlikely to have one.

Measurement procedures: Detailed procedures for making sound level measurements are spelled out in the American National Standards Institute's Standard Methods ANSI S1.2-1962(R1976) *American National Standard Method for the Physical Measurement of Sound* and ANSI S1.13-1971(R1976) *American National Standard Methods for the Measurement of Sound Pressure Levels*.

Some of the basic procedures that should be followed are:

1. Measurements should normally be made over a continuous 24 hour period. If this is not possible, measurements may be made over a period of days but still must cover the entire 24 hour period. The selection of the days becomes even more critical so that they are as similar as possible. Sampling is not acceptable.
2. The sound level meter must be calibrated before each use.
3. The sound level meter should be provided with a wind screen.
4. Care should be taken to insure that there are no temporary obstructions, such as parked trucks, between the meter and the source.

The Noise Study

The noise study prepared to describe the measurement results should contain at least the following:

1. A map showing where the measurements were taken
2. A vicinity map showing the site and the major noise sources
3. A chart indicating the date, the time, and weather conditions when measurements were taken at each measurement location
4. The type of microphone used
5. Any variations from ANSI procedures
6. The results of the measurements in L_{dn} for each measurement location
7. Any unusual conditions that existed during the measurement period—i.e. construction activity, major traffic tieup, etc.
8. If an integrating sound level meter was not used, the calculations used to derive the L_{dn} value.

**U.S. Department of Housing and Urban
Development**
Office of Community Planning and Development



Noise Notebook

Chapter 4
Supplement

Sound Transmission Class Guidance

Table of Contents

| Title | Page |
|---|------|
| Introduction | 1 |
| What is Sound | 1 |
| Sound Reduction in Structures | 1 |
| Elimination | 2 |
| Absorption | 2 |
| Sound Barriers | 2 |
| Design | 3 |
| Weather and Sound | 3 |
| STC Ratings for Wall, Floor and Window Materials and Assemblies | 3 |
| Appendix A STC Ratings | A-1 |
| Walls | A-1 |
| Exterior | A-1 |
| Interior | A-9 |
| Wooden Studs | A-9 |
| Metal Studs | A-14 |
| Floors | A-16 |
| Wood | A-16 |
| Concrete - | A-21 |
| Windows | A-24 |
| Doors | A-27 |
| Exterior | A-27 |
| Interior | A-29 |
| Appendix B References | B-1 |

Sound Transmission Class Guidance

Introduction

The Noise Guidebook, pages 33-37, provides an elementary discussion of STC, provides some STC ratings for common building materials and limited exterior and interior wall construction configurations, and describes a method to determine composite STC value of a wall containing a window or door. This update provides for an understanding of STC and provides an expanded material and construction classification for both internal and external building materials and typical construction patterns.

The intent of this chapter is not to endorse anyone building manufacturer or product over another but to keep HUD Environmental staff and other interested persons advised on the STC values of current building materials and practices which can be applied to HUD supported housing activities. Additional subsections on specific types of building materials, construction techniques and STC values will be periodically added.

As stated in the Noise Guidebook, "STC is used as a measure of a material's ability to reduce sound," and effectively mitigate any adverse noise levels that could impede a person's use of a residential or commercial structure. The higher the STC value, the greater the sound attenuation and presumably the quieter the structure's interior. In addition to STC, another interior building measuring technique to evaluate sound impact or absorption between floors is the Impact Isolation Class (IIC). Both techniques will be fully discussed after a brief explanation of the following basic principals related to sound.

What Is Sound

Sound is indicated in two ways: frequency and intensity. Frequency, the high or low pitch of sound, is expressed as the number of vibrations or cycles per second. One vibration or cycle per second is a hertz (Hz). For example on a piano the middle C note has a frequency of 262 Hz and the total range of a piano has a frequency of 27 Hz to 4186 Hz, well within the 16 to 20,000 Hz range of the human ear. The sound created by the piano is heard by the human ear by air pressure created by vibration. The greater the pressure, the greater the loudness or intensity of the sound heard by the human ear. Loudness is expressed in decibels (dB). The decibel is one-tenth of a "Bel," a unit named for Alexander Graham Bell. Since the ear is more sensitive to sound in the middle range of frequencies, loudness (intensity) is determined at a frequency of 1,000 Hz. On the decibel scale, 0 dB indicates a level of sound at 1,000 Hz, a sound just

barely audible to person with normal unimpaired hearing.

The A-weighted scale of a sound meter is designed to adjust the sensitivity of a sound meter to sounds of different frequencies that closely approximate how the human ear might respond to moderate sound levels in the 1,000 to 4,000 Hz range. The A-weighted sound level is used extensively for measuring community and transportation noises.

The Sound Transmission Class (STC), measured in decibels, is used to measure building material's ability to absorb sound. The STC can be used to measure sound absorption for both external building walls and internal walls in single and multifamily structures. The STC is measured by positioning a representative sample of the building material midway in an acoustical chamber, dividing the chamber in half or into two rooms. One section of the chamber contains the sound source and the other section the sound receiving equipment. The test procedure calls for a steady sound in the source room and measuring the sound level in both the source and receiving rooms. Differences in sound levels in the rooms determines the transmission loss characteristics of the material tested. For example, if a generated sound level of 80 dB is measured in the source room and 30 dB is measured in the adjacent receiving room, the tested material has a sound reduction intensity (STC) of 50dB.

The Impact Isolation Class (IIC), measured in decibels, is the classification system used to determine sound *impact* from floor to ceiling in a structure. The IIC is not to be used to measure airborne sound penetration or absorption in walls. The IIC numerical rating efficiency increases with improved impact isolation performance of the floor and its component sub flooring and materials. The rating scale values are generally equivalent to the airborne sound transmission loss. The impact of steps or vibrations on a floor and the reverberation of that noise in the room below is dependent upon the type, density and thickness of the floor and ceiling material, its absorption material, and quality of construction. A separate section on common floor materials and construction patterns to illustrate both the STC and IIC ratings is included.

Sound Reduction In Structures

Four general techniques for controlling noise in single-family and multifamily structures are:

1. Elimination of the cause or source of the noise,
2. Employ materials which absorb sound rather than reflect noise,

3. Use sound barriers in building layout to prevent sound from being transmitted from one adjoining area into another, and
4. Use design considerations to mask or absorb the noise.

A description of each technique and its applicability follows.

1. ELIMINATION:

The elimination of a noise source may be impractical or impossible to achieve, whether emanating from within or outside the structure. Examples include the operation of mechanical equipment within the dwelling unit, excessive corridor noise, air conditioning/heating system, elevators, exhaust fans, and outdoor transportation sounds such as automotive traffic, aircraft overflights, and commercial or industrial activities. Some noise reduction could be achieved through sound reduction or absorption techniques, but total elimination of these sounds may be impossible.

2. ABSORPTION:

Sound absorption control is the reduction of sound emanating from a source within a room. The extent of control depends upon the efficiency of the room's surfaces in absorbing rather than reflecting sound waves. A surface, which could theoretically absorb 100% of the sound would have a sound absorption coefficient of 1.0. A surface absorbing 35% of the sound would have a coefficient of 0.35. The effectiveness of wall construction as a means of sound absorption is tested in a similar manner as that of STC. If a generated sound level of 80 dB is observed in one room and 30 dB is measured in an adjacent room, the reduction in sound absorption for the intervening wall is 50 dB. In choosing the type of construction material for interior walls to absorb sound transmission, porosity and density of the material should be considered. Resistance to sound transmission increases with unit weight and decreases with porosity. For example, unpainted, open textured concrete block exhibits improved resistance to sound passage after sealing the surface with plaster or paint. The sealing of the pores result in a reduction in the sound absorption of the block. In multifamily structures using concrete block partitions to separate public areas such as stairwells and corridors from adjacent living areas, sound transmission reduction is achieved through plastering or painting the surface of the residential unit or living area on the opposite side of the partition. The sound is absorbed by the concrete masonry's unpainted side and its transmission is prevented into the residential unit or living area by the plaster or paint on the other side.

However, all of the design elements that are employed to control sound can be nullified through poor or improper construction practices. Sound

leakage will occur through any opening in a wall. An improperly fitted door or window is a prime source of sound leakage, as well as openings around ducts, pipes and electrical outlets which are improperly fitted or sealed.

3. SOUND BARRIERS:

Prudent building layout can be effective in controlling noise in single-family and multifamily housing. Sound waves can be prevented from being transmitted from one adjoining area to another. Closets, stairways and corridors can be used as buffers against airborne sound transmission between apartments or bedrooms. Concrete blocks or solid partitions can be employed to separate boiler rooms, air conditioning units, work areas or noisy public areas such as stairwells, corridors or lobbies from adjacent living areas. Partitions designed to absorb sound on one side and to retain sound absorption on the other can effectively block or reduce sound transmission into living areas intended for quiet use. The barrier should have a high sound absorption coefficient on one side and an equally high sound retention coefficient on the reverse side to effective. For example, unpainted porous concrete block would have a high sound absorption coefficient and a high noise retention coefficient on the reverse side if the porous surface in the living unit was effectively sealed by plaster or paint. Similarly, noise originators such as cloths washing machines, central heaters, and other noisy major appliances can be placed in a basement or utility rooms that are physically isolated from other living areas by walls or floors to absorb or block the emitted sounds.

4. DESIGN:

Design factors is the last major element to consider in controlling noise in single-family and multifamily structures. Design considerations offer the most infinite prospects for controlling noise due to the numerous types of building designs. For example, adjacent apartments can be arranged to have quiet areas (bedrooms or living rooms) abut and have noisy areas (kitchens and bathrooms) next to similar noisy areas. Apartment door openings into the same hallway can be staggered to reduce sound penetration into the unit directly across the hall. Since sound travels in a straight line, some of the sound from one doorway would be absorbed or diffused into the wall building material of the unit directly across the hall.

Windows should be placed as far away as possible from common walls. The closer the windows are to each other, the more sound will pass from one apartment to another. Medicine cabinets in opposite bathroom partitions should be offset. Cabinets placed back-to-back will transmit almost as much noise as an opening. Heating/cooling ducts are like speaking tubes, carrying noise from one room to another. Techniques should be employed to trap or splinter

sound or have turns in the ducts to reduce noise transference.

Noise producing equipment should be kept as far as possible from living areas and especially the bedrooms. Flexible connectors should be used to couple mechanical equipment to pipes and ducts. Pipes and ducts should not be firmly connected to parts of a building that could serve as sounding boards but be supported by resilient connections to solid supports. Where pipes and ducts pass through walls and floors, they should be isolated by gaskets. The acoustical integrity of a building or a building section with an otherwise adequate STC rating can be significantly reduced by a small hole or crack in the exterior wall or any other path that allows sound to bypass the exterior or interior walls and flow into other areas of the structure.

Weather and Sound

Air will attenuate noise at high frequencies usually from 1,000 Hz upwards. Sound absorption by air changes with wind speed, temperature and humidity. For example, wind blowing at slower speeds near the ground surface than at higher elevations will produce a bending of the sound upwards, resulting in less noise at ground level. Temperature gradients have a similar effect because the velocity of sound increases with the higher temperatures. If the temperature is higher near the ground than in the upper layers (usually the case during the day), the sound waves higher above the ground will travel slower and the sound will be bent upwards resulting in quieter conditions at ground level. The reverse is true at night, the temperature is lower near the ground, sound will bend towards the ground, increasing noise at the ground level. Wind and temperature- gradient effects can also account for the occasional freak reception of sounds over long distances, especially train whistles. The sound has been bent upwards by a temperature or wind gradient and after traveling some way at high level is bent down again by a reverse gradient.

Weather conditions can produce substantial variations of as much as +- 10 dB. For example, fog causes an increase in the absorption in the air. A moderately dense fog, visibility 150 feet, gives extra attenuation of 1 to 3 dB per 300 feet, depending on frequency. Similarly, snow forms an absorbent layer on the ground, which affects ground reflection, thereby reducing the sound level.

Weather can also be a significant source of noise in a structure. Common irritants are wind and rain. Wind whistling around a building, into ventilation grilles, screens or past other external architectural or artistic features can result in disturbing noise. Similarly, the

impact of rain on lightweight roofing, gutters or skylights can produce high internal noise levels.

STC Ratings for Wall, Floor and Window Materials and Assemblies

Appendix A illustrates sound transmission class ratings for wall, floor, window and door assemblies. The data used in this section is compiled from laboratory reports and various technical and trade literature publications received by this Office. Each item has an assigned STC rating, an accompanying sketch and a brief description of its composition or assembly. In addition, where possible, an Impact Isolation Class (IIC) rating has been assigned to floors to determine sound impact from floor to ceiling. Appendix A is a guide designed to aid HUD Housing and Environmental personal in determining STC values for most common housing construction practices and materials used in residential construction. The STC information can be used to supplement acoustical measurements by providing approximate interior noise levels for existing or proposed dwellings located in high noise areas by deducting the STC value from the exterior noise level. The data could also be used to advise HUD clients in determining and achieving compliance with the noise criteria stated in 24 CFR Part 51 B through the use of common construction materials and techniques to achieve noise attenuation for new construction and rehabilitation.

The appendix is divided into the following subsections:

1. WALLS
 - Exterior
 - Interior
2. FLOORS
 - Wood
 - Concrete
3. WINDOWS
4. DOORS
 - Exterior
 - Interior

A bibliography of the reports, manufacturer's catalogs, technical papers, testing laboratories and other publications used in compiling this data is listed in the Appendix B.

Appendix A STC Ratings

Appendix A

Walls: Exterior

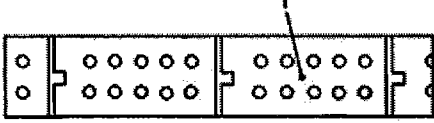
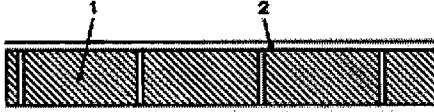
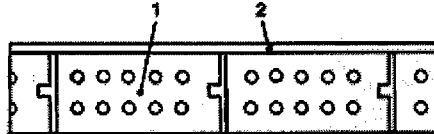
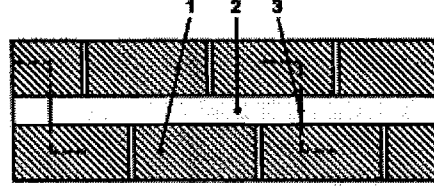
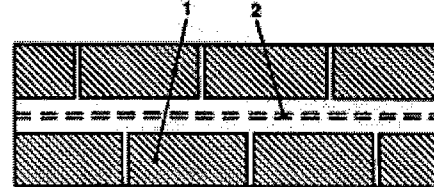

STC Ratings

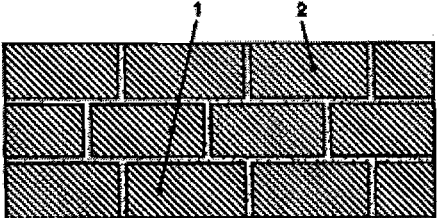
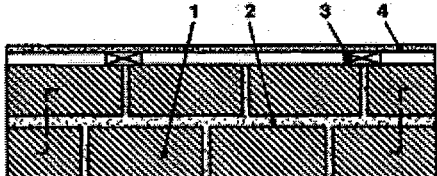
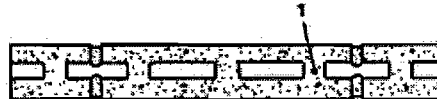
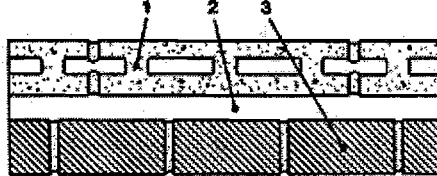
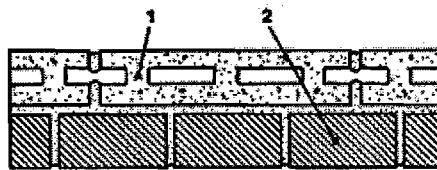
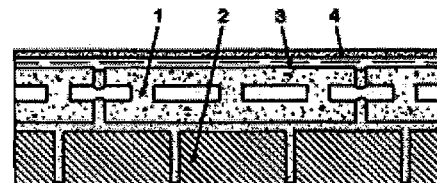
| Sketch | Brief Description | STC |
|---|---|-----|
|  | <p>1. 4" face brick, mortared together.</p> | 45 |
|  | <p>1. Hollow core brick, mortared together.</p> | 51 |
|  | <p>1. Common brick, mortared together. 2. 1/2" gypsum/sand plaster.</p> | 50 |
|  | <p>1. Hollow core brick, mortared together. 2. 1/2" gypsum/sand plaster.</p> | 53 |
|  | <p>1. Face brick, mortared together. 2. 2" air space. 3. Metal ties.</p> | 50 |
|  | <p>1. Brick, mortared together. 2. 2 1/4" cavity filled with concrete grout and #6 bars vertically 48"o.c. and #5 bars horizontally 30"o.c.</p> | 59 |

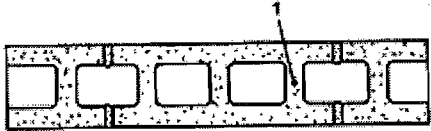
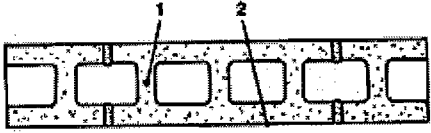
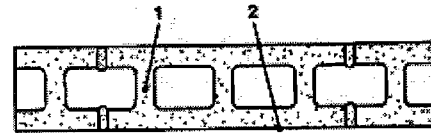
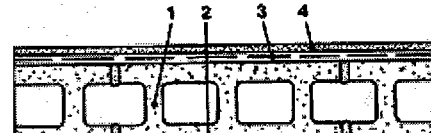
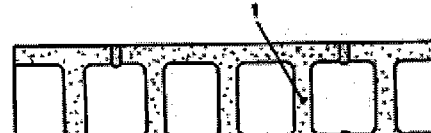
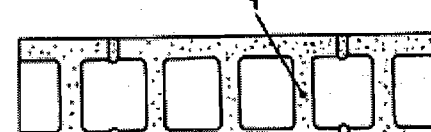
| Sketch | Brief Description | STC |
|---|--|-----|
|  | <ol style="list-style-type: none"> 1. Common brick, mortared together. 2. Face brick, mortared together. | 59 |
|  | <ol style="list-style-type: none"> 1. Common brick, mortared together. 2. 3/4" mortar-filled cavity with metal Z ties 24"o.c. in both directions. 3. 1x3" furring strips 16"o.c. and nailed vertically into mortar joints 12"o.c. 4. 1/2" gypsum board nailed 8"o.c. along edges and 12"o.c. in field. | 53 |
|  | <ol style="list-style-type: none"> 1. 4x8x16" 3-cell lightweight concrete masonry units (17 lbs./block). | 40 |
|  | <ol style="list-style-type: none"> 1. 4x8x18" 3-cell lightweight concrete masonry units (19 lbs./block). 2. 2" air cavity. 3. Common brick, mortared together. | 54 |
|  | <ol style="list-style-type: none"> 1. 4x8x18" 3-cell lightweight concrete masonry units (19 lbs./block). 2. Common brick, mortared together. (brick headers after every second course of block to tie the wythes together). | 51 |
|  | <ol style="list-style-type: none"> 1. 4x8x18" 3-cell lightweight concrete masonry units (19 lbs./block). 2. Common brick, mortared together. 3. Resilient channels. 4. 1/2" gypsum board screwed to channels. | 56 |

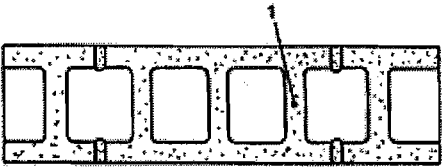
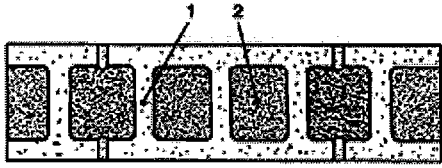
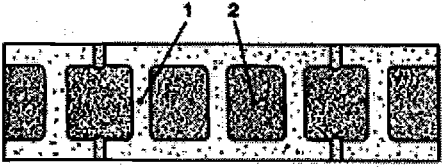
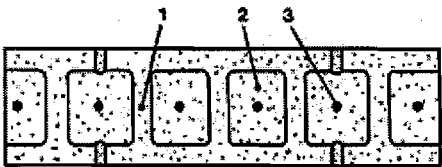
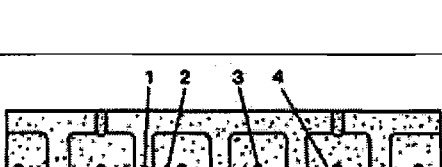
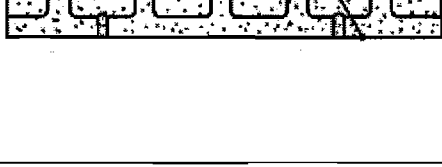
| Sketch | Brief Description | STC |
|---|---|-----|
|  | 1. 6x8x16" 3-cell lightweight concrete masonry units (21 lbs./block). | 44 |
|  | 1. 6x8x16" 3-cell lightweight concrete masonry units (21 lbs./block). 2. Paint both sides with primer-sealer coat and finish coat of latex. | 46 |
|  | 1. 6x8x18" 3-cell dense concrete masonry units (36 lbs./block). 2. Paint both sides with primer-sealer coat and finish coat of latex. | 48 |
|  | 1. 6x8x16" 3-cell lightweight concrete masonry units (21 lbs./block). 2. Paint, primer-sealer coat and finish coat of latex. 3. Resilient channels, 24" o.c. 4. 1/2" gypsum board screwed to channels. | 53 |
|  | 1. 8x8x16" 3-cell lightweight concrete masonry units (28 lbs./block). | 45 |
|  | 1. 8x8x18" 3-cell lightweight concrete masonry units (34 lbs./block). | 49 |

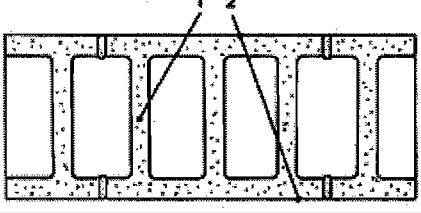
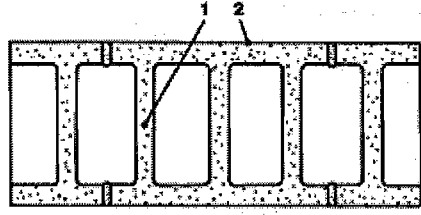
| Sketch | Brief Description | STC |
|---|---|-----|
|  | 1. 8x8x18" 3-cell lightweight concrete masonry units (38 lbs./block). | 49 |
|  | 1. 8x8x18" 3-cell lightweight concrete masonry units (34 lbs./block). 2. Expanded mineral loose-fill insulation. | 51 |
|  | 1. 8x8x18" 3-cell lightweight concrete masonry units (38 lbs./block). 2. Expanded mineral loose-fill insulation. | 51 |
|  | 1. 8x8x18" 3-cell lightweight concrete masonry units (33 lbs./block). 2. Grout in cells. 3. #5 bar in each cell. | 48 |
|  | 1. 8x8x18" 3-cell lightweight concrete masonry units (33 lbs./block). 2. Grout in cells. 3. #5 bar each cell. 4. Paint two coats flat latex each side. | 55 |
|  | 1. 12x8x16" 3-cell lightweight concrete masonry units (43 lbs./block). | 39 |

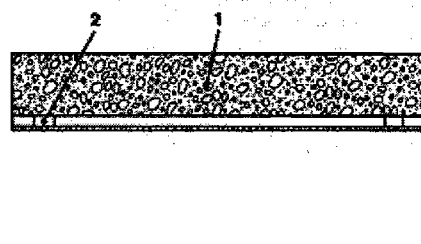
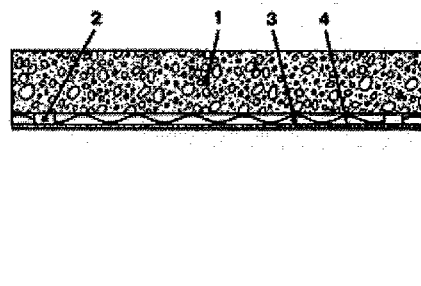
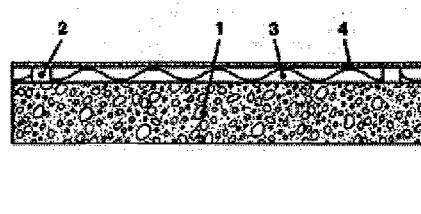

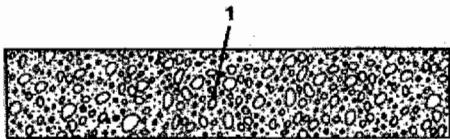
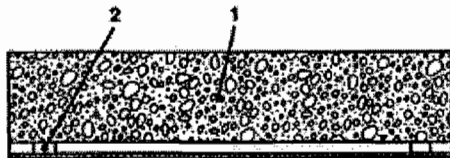
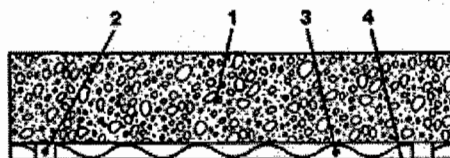
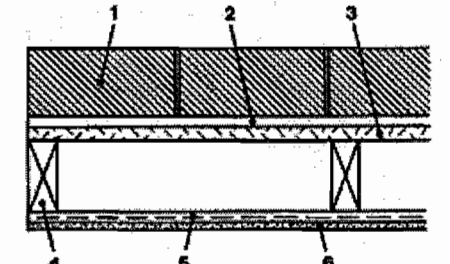
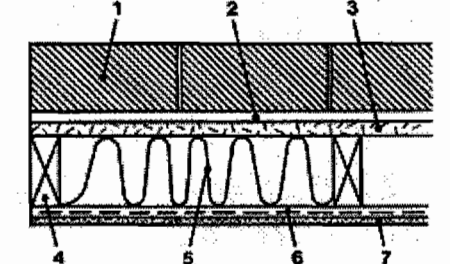

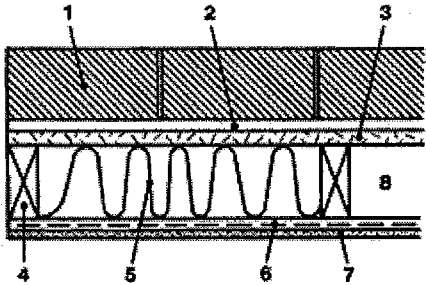
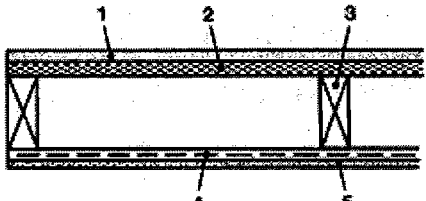
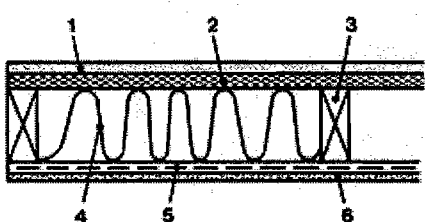
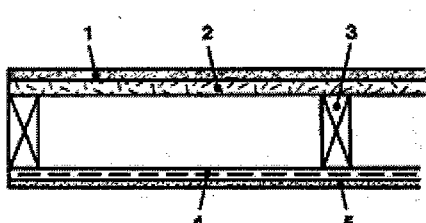
| Sketch | Brief Description | STC |
|---|---|-----|
|  | <ol style="list-style-type: none"> 1. 12x8x16. 3-cell lightweight concrete masonry units (43 lbs./block). 2. Paint both sides with 3 coats of latex block filler. | 50 |
|  | <ol style="list-style-type: none"> 1. 12x8x16" 3-cell lightweight concrete masonry units (43 lbs./block). 2. Paint one side only with 3 coats latex block filler. | 51 |
|  | <ol style="list-style-type: none"> 1. 6" cast concrete wall (71 psf). | 57 |
|  | <ol style="list-style-type: none"> 1. 6" cast concrete wall. 2. "Z" furring channels. 3. 1/2" gypsum board. | 59 |
|  | <ol style="list-style-type: none"> 1. 6" cast concrete wall. 2. "Z" furring channels. 3. 1", 8-pcf rockwool. 4. 1/2" gypsum board. | 62 |
|  | <ol style="list-style-type: none"> 1. 6" cast concrete wall. 2. 2x2" wood furring. 3. 1 1/2" 4-pcf rockwool. 4. 1/2" gypsum board. | 63 |

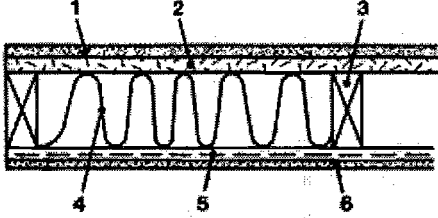
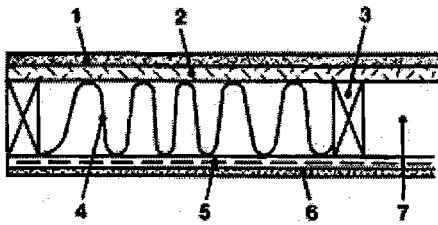

| Sketch | Brief Description | STC |
|---|---|-----|
|  | 1. 8" cast concrete wall (96.6 psf). | 58 |
|  | 1. 8" cast concrete wall. 2. 2x2" wood furring. 3. 1/2" gypsum board. | 59 |
|  | 1. 8" cast concrete wall. 2. 2x2" wood furring. 3. 1 1/2", 4 psf rockwall. 4. 1/2" gypsum board. | 63 |
|  | 1. Face brick. 2. 1/2" air space, with metal ties. 3. 3/4" insulation board sheathing. 4. 2x4" studs 16"o.c. 5. Resilient channel. 6. 1/2" gypsum board. | 54 |
|  | 1. Face brick. 2. 1/2" air space, with metal ties. 3. 3/4" insulation board sheathing. 4. 2x4" studs 16"o.c. 5. Fiberglas building insulation (3 1/2"). 6. Resilient channel. 7. 1/2" gypsum board. | 56 |

| Sketch | Brief Description | STC |
|---|--|-----|
|  | <ol style="list-style-type: none"> 1. Face brick (9x14' wall). 2. 1/2" air space, with metal ties. 3. 3/4" insulation board sheathing. 4. 2x4" studs 16"o.c. 5. Fiberglass building insulation (3 1/2"). 6. Resilient channel. 7. 1/2" gypsum board. 8. Wall penetrated by 6x5' picture window 1" glazed insulating glass. | 39 |
|  | <ol style="list-style-type: none"> 1. 7/8" stucco. 2. No.15 felt building paper and 1" wire mesh. 3. 2x4" studs 16"o.c. 4. Resilient channel. 5. 1/2" gypsum board screwed to channel. | 49 |
|  | <ol style="list-style-type: none"> 1. 7/8" stucco. 2. No.15 felt building paper and 1" wire mesh. 3. 2x4" studs 16"o.c. 4. Fiberglass building insulation (3 1/2"). 5. Resilient channel. 6. 1/2" gypsum board screwed to channel. | 57 |
|  | <ol style="list-style-type: none"> 1. 5/8 x 10" redwood siding. 2. 1/2" insulation board sheathing. 3. 2x4" wood studs 16"o.c. 4. Resilient channel. 5. 1/2" gypsum board screwed to channel. | 43 |

| Sketch | Brief Description | STC |
|---|--|------------------|
|  | <ol style="list-style-type: none"> 1. 5/8x10" redwood siding. 2. 1/2" insulation board sheathing. 3. 2x4" wood studs 16"o.c. 4. Fiberglas building insulation (3 1/2"). 5. Resilient channel. 6. 1/2" gypsum board screwed to channel. | 47 |
|  | <ol style="list-style-type: none"> 1. 5/8x10" redwood siding (9x14' wall). 2. 1/2" insulation board sheathing. 3. 2x4" wood studs 16.o.c. 4. Fiberglas building insulation (3 1/2"). 5. Resilient channel. 6. 1/2" gypsum board screwed to channel. 7. <ul style="list-style-type: none"> a. Wall penetrated by a 6x5' picture window, 1" glazed insulating glass. b. Wall penetrated by a 6x5' 16 panel window, glazed single strength. | (a.38) (b.35) |

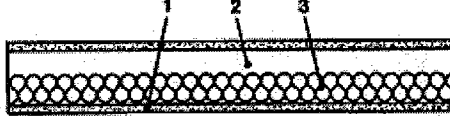
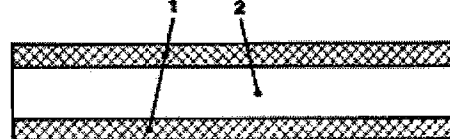
WALLS: Interior: Wooden Studs

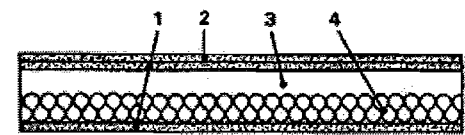
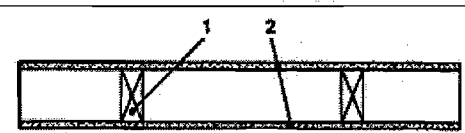
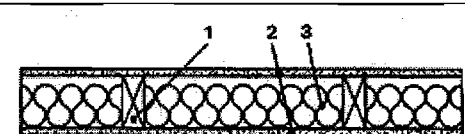
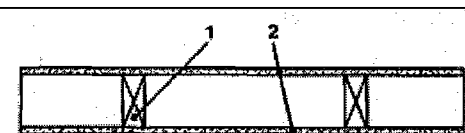
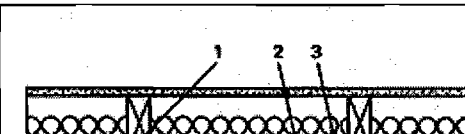
| Sketch | Brief Description | STC |
|---|--|-----|
|  | <ol style="list-style-type: none"> 1. 1/2" gypsum board. 2. 3/16" plywood laminated with contact cement. | 28 |
|  | <ol style="list-style-type: none"> 1. 1/2" gypsum board. 2. 1/2" wood-fiber board laminated with gypsum joint compound. | 30 |
|  | <ol style="list-style-type: none"> 1. 2x4" studs, 16"o.c. 2. 5/8" gypsum board screwed to studs. | 28 |
|  | <ol style="list-style-type: none"> 1. 1/2" gypsum board, no studs. 2. 2 1/2" air space. | 30 |
|  | <ol style="list-style-type: none"> 1. 1/2" gypsum board, no studs. 2. 2 1/2" air space. 3. 2" thick sound attenuation blanket. | 44 |
|  | <ol style="list-style-type: none"> 1. 1/2" gypsum board, no studs. 2. 3 5/8" air space. 3. 2" thick sound attenuation blanket. | 45 |
|  | <ol style="list-style-type: none"> 1. 1 3/8" thick wood-fiber board nailed to 2x4" plates top and bottom and painted both sides. 2. 3 1/2" air cavity. | 44 |



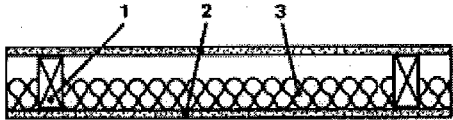
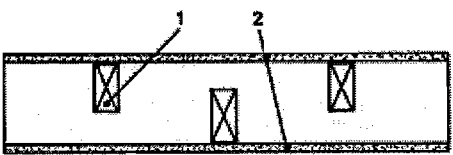
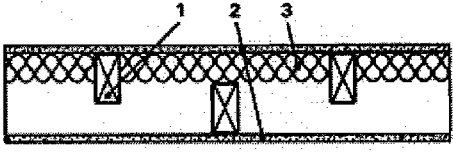
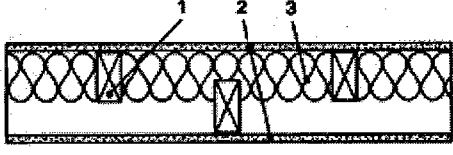
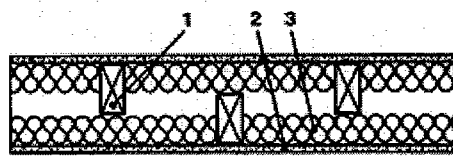
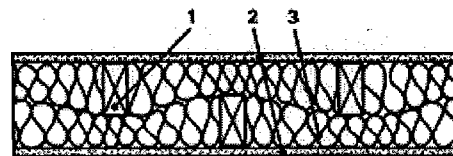

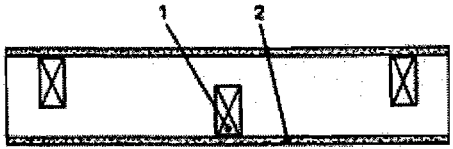
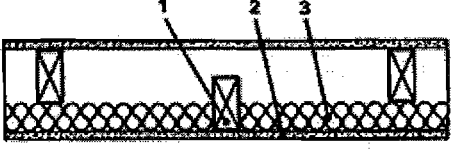
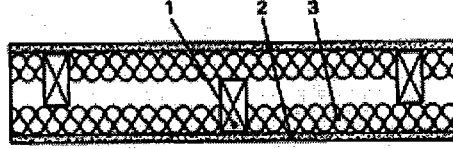
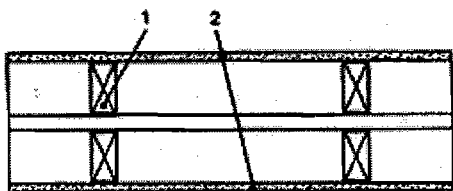
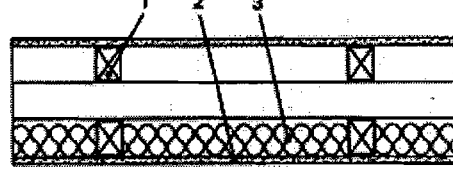
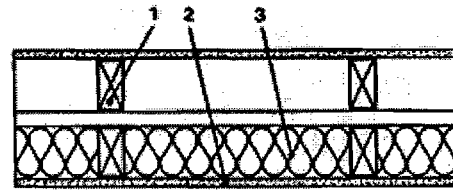
| Sketch | Brief Description | STC |
|---|--|-----|
|  | <ol style="list-style-type: none"> 1. 1/2" gypsum board, no studs. 2. 1/2" gypsum board laminated to base layer with gypsum joint compound. 3. 3 5/8" air cavity. 4. 2" thick sound attenuation blanket. | 48 |
|  | <ol style="list-style-type: none"> 1. 2x4" studs, 16"o.c. 2. 3/8" gypsum board nailed to studs. | 35 |
|  | <ol style="list-style-type: none"> 1. 2x4" studs, 16"o.c. 2. 3/8" gypsum board nailed to studs. 3. 3" thick sound attenuation blanket. | 41 |
|  | <ol style="list-style-type: none"> 1. 2x4" studs, 16"o.c. 2. 1/2" gypsum board screwed to studs. | 34 |
|  | <ol style="list-style-type: none"> 1. 2x4" studs, 16"o.c. 2. 1/2" gypsum board screwed to studs. 3. 2" thick sound attenuation blanket. | 37 |
|  | <ol style="list-style-type: none"> 1. 2x4" studs, 24"o.c. 2. 1/2" gypsum board screwed to studs. | 36 |

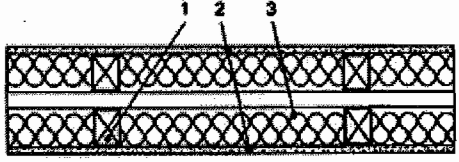
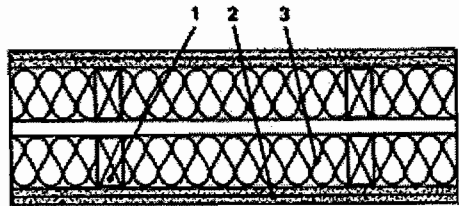

| Sketch | Brief Description | STC |
|---|---|-----|
|  | <ol style="list-style-type: none"> 1. 2x4" studs, 24" o.c. 2. 1/2" gypsum board screwed to studs. 3. 2" thick sound attenuation blanket. | 40 |
|  | <ol style="list-style-type: none"> 1. 2x4" studs spaced 16" o.c. and staggered 8" o.c. on 2x6" plates. 2. 1/2" gypsum board screwed 12" o.c. | 39 |
|  | <ol style="list-style-type: none"> 1. 2x4" studs spaced 16" o.c. and staggered 8" o.c. on 2x6" plates. 2. 1/2" gypsum board screwed 12" o.c. 3. 2 1/4" thick sound attenuation blanket. | 48 |
|  | <ol style="list-style-type: none"> 1. 2x4" studs spaced 16" o.c. and staggered 8" o.c. on 2x6" plates. 2. 1/2" gypsum board screwed 12" o.c. 3. 3 1/2" thick sound attenuation blanket. | 49 |
|  | <ol style="list-style-type: none"> 1. 2x4" studs spaced 16" o.c. and staggered 8" o.c. on 2x6" plates. 2. 1/2" gypsum board screwed 12" o.c. 3. 2 1/4" thick sound attenuation blankets in both stud cavities. | 49 |
|  | <ol style="list-style-type: none"> 1. 2x4" studs spaced 16" o.c. and staggered 8" o.c. on 2x6" plates. 2. 1/2" gypsum board screwed 12" o.c. 3. 3 1/2" thick sound attenuation blankets in both stud cavities. | 51 |

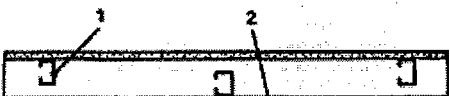
| Sketch | Brief Description | STC |
|---|--|-----|
|  | <ol style="list-style-type: none"> 1. 2x4" studs spaced 24"o.c. and staggered 12"o.c. on 2x6" plates. 2. 1/2" type X gypsum board screwed 12"o.c. | 42 |
|  | <ol style="list-style-type: none"> 1. 2x4" studs spaced 24"o.c. and staggered 12"o.c. on 2x6" plates. 2. 1/2" gypsum board screwed to studs. 3. 2" thick sound attenuation blanket. | 46 |
|  | <ol style="list-style-type: none"> 1. 2x4" studs spaced 24"o.c. and staggered 12"o.c. on 2x6" plates. 2. 1/2" type X gypsum board screwed 12"o.c. 3. 2" thick sound attenuation blankets in both stud cavities. | 48 |
|  | <ol style="list-style-type: none"> 1. Double row of 2x4" studs 16"o.c. on separate plates spaced 1" apart. 2. 1/2" type X gypsum board screwed 12"o.c. | 47 |
|  | <ol style="list-style-type: none"> 1. Double row of 2x3" studs 16"o.c. on 2x3" plates spaced 2 1/2" apart. 2. 1/2" gypsum board screwed 16"o.c. 3. 2 1/4" thick sound attenuation blanket. | 55 |
|  | <ol style="list-style-type: none"> 1. Double row of 2x4" studs 16"o.c. on separate plates spaced 1" apart. 2. 1/2" type X gypsum board screwed 12"o.c. 3. 3 1/2" thick sound attenuation blanket. | 56 |

| Sketch | Brief Description | STC |
|---|---|-----|
|  | <ol style="list-style-type: none"> 1. Double row of 2x4" studs 16"o.c. on separate plates spaced 1" apart. 2. 1/2" gypsum board screwed 12"o.c. 3. 2 1/4" thick sound attenuation blankets in both stud cavities. | 56 |
|  | <ol style="list-style-type: none"> 1. Double row of 2x4" studs 16.o.c. on separate plates spaced 1" apart. 2. Double row of 5/8" type X gypsum board screwed 16.o.c. 3. 3 1/2" thick sound attenuation blankets in both stud cavities. | 63 |

WALLS: Interior: Metal Studs

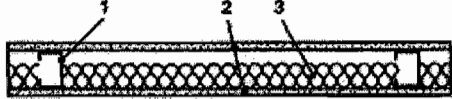
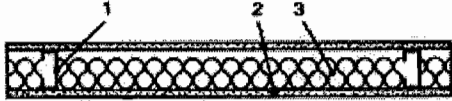
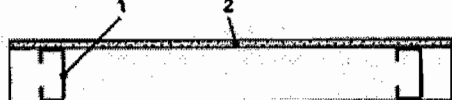
| Sketch | Brief Description | STC |
|---|--|-----|
|  | <ol style="list-style-type: none"> 1. 1 5/8" metal studs, 24"o.c. 2. 1/2. vinyl-faced gypsum board screwed to studs. | 27 |
|  | <ol style="list-style-type: none"> 1. 1 5/8" metal studs spaced 24"o.c. and staggered 12"o.c. on 2 1/2" metal tracks. 2. 1/2" gypsum board screwed to studs. | 34 |
|  | <ol style="list-style-type: none"> 1. 1 5/8" metal studs, 24"o.c. 2. 5/8" gypsum board screwed 12"o.c. at edges and 24"o.c. in field. | 37 |
|  | <ol style="list-style-type: none"> 1. 1 5/8" metal studs spaced 24"o.c. and staggered 12"o.c. on 2 1/2" metal channels. 2. 5/8" gypsum board screwed to studs. | 38 |
|  | <ol style="list-style-type: none"> 1. 2 1/2" metal studs, 24"o.c. 2. 1/2" vinyl-faced gypsum board screwed to studs. | 27 |
|  | <ol style="list-style-type: none"> 1. 2 1/2" metal studs, 24"o.c. 2. 5/8" gypsum board screwed to studs. | 37 |

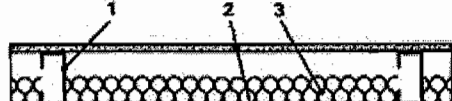
| Sketch | Brief Description | STC |
|---|---|-----|
|  | <ol style="list-style-type: none"> 1. 2 1/2" metal studs, 24"o.c. 2. 5/8" gypsum board screwed 12"o.c. at edges and 24"o.c. in field. 3. 1 1/2" thick sound attenuation blanket. | 42 |
|  | <ol style="list-style-type: none"> 1. 2 1/2" metal studs, 24"o.c. 2. 1/2" gypsum board screwed to studs. 3. 2" thick sound attenuation blanket. | 44 |
|  | <ol style="list-style-type: none"> 1. 3 5/8" metal studs, 24"o.c. 2. 1/2" gypsum board screwed to studs. | 27 |
|  | <ol style="list-style-type: none"> 1. 3 5/8" metal studs, 24"o.c. 2. 1/2" gypsum board screwed to studs. | 36 |
|  | <ol style="list-style-type: none"> 1. 3 5/8" metal studs, 24"o.c. 2. 1/2" gypsum board screwed to studs. 3. 2" thick sound attenuation blanket. | 44 |

Floors: Wood

| Sketch | Brief Description | STC (IIC) |
|--------|--|---|
| | <ol style="list-style-type: none"> 1. 2x8" wooden joists, 16"o.c. 2. 7/8" tongue and groove nailed to joists. 3. 3/8" gypsum nailed to joists. | NA (32) |
| | <ol style="list-style-type: none"> 1. 2x8" wooden joists, 16"o.c. 2. 1/2" plywood nailed. 3. 25/32" hardwood flooring. 4. 1/2" gypsum nailed to joists. 5. Ceiling tire. | NA (37) |
| | <ol style="list-style-type: none"> 1. 2x8" wooden joists, 16"o.c. 2. 5/8" tongue and groove plywood nailed with 8d nails 6"o.c. 3. 3/8" plywood stapled 3"o.c. at edges and 6"o.c. in field. 4. .075" sheet vinyl. 5. Resilient channels, 24"o.c. 6. 5/8" gypsum board screwed 12"o.c. 7. 3" thick sound attenuation blanket. | 46 (44) |
| | <ol style="list-style-type: none"> 1. 2x8" wooden joists, 16"o.c. 2. 5/8" plywood nailed with 8d nails. 3. 1/2" nominal wood-fiber board glued to plywood. 4. 44 oz. carpet on 50 oz. pad. 5. Resilient channels, 24"o.c. 6. 5/8" gypsum board screwed 12"o.c. | 48 (65) |
| | <ol style="list-style-type: none"> 1. 2x8" wooden joists, 16"o.c. 2. 19/32" tongue and groove plywood nailed with 8d nails 6"o.c. at edges and 10"o.c. in field. 3. <ol style="list-style-type: none"> a. 44 oz. carpet on 40 oz. hair pad. b. .075" sheet vinyl. c. 1/16" sheet vinyl. 4. Resilient channels, 24"o.c. 5. 5/8" gypsum board screwed 12"o.c. 6. 3" thick sound attenuation blanket. | 48 (a. 69) (b. 45) (c. 43) |

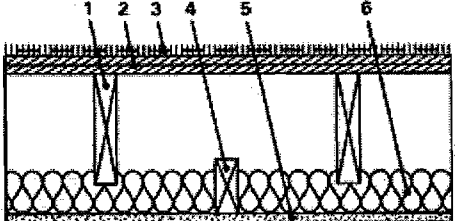
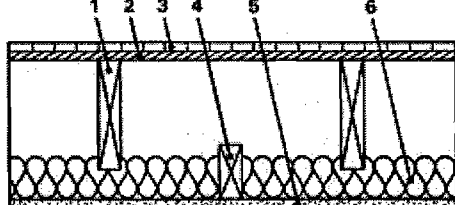
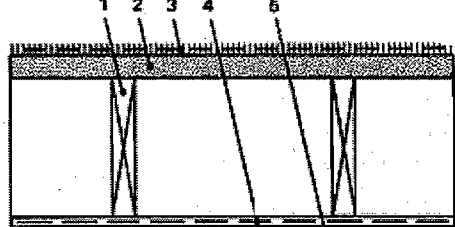
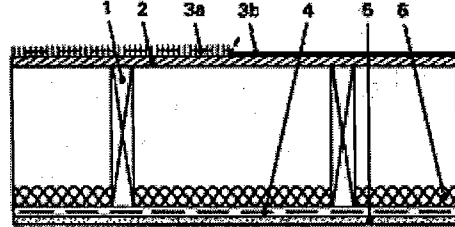

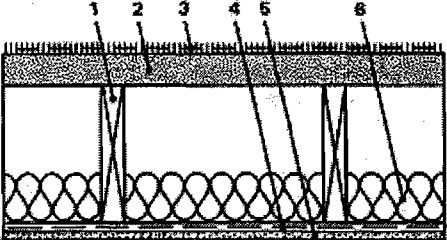
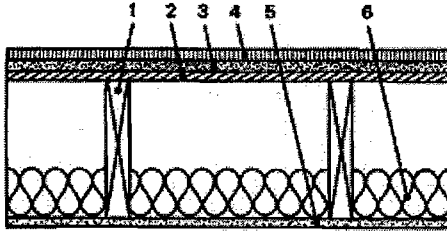
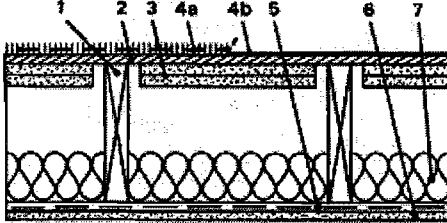
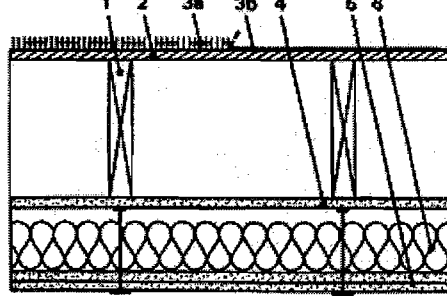
| Sketch | Brief Description | STC (IIC) |
|---|---|------------------------------|
|  | <ol style="list-style-type: none"> 1. 2x8" wooden joists, 16"o.c. 2. 1 1/8" tongue and groove plywood nailed 6"o.c. at edges and 16"o.c. in field. 3. 44 oz. wool carpet on 40 oz. hair pad. 4. 2x4" ceiling joists, 16"o.c. and staggered between floor joists. 5. 5/8" gypsum board nailed to 2x4" joists. 6. 3" thick sound attenuation blanket. | 53 (80) |
|  | <ol style="list-style-type: none"> 1. 2x8" wooden joists, 16"o.c. 2. 1/2" plywood nailed with 8d nails 6"o.c. at edges and 16"o.c. in field. 3. 25/32" wood strip flooring nailed to sub floor. 4. 2x4" wooden ceiling joists, 16"o.c. and staggered between floor joists. 5. 5/8" gypsum board nailed to 2x4" joists. 6. 3" thick sound attenuation blanket. | 54 (45) |
|  | <ol style="list-style-type: none"> 1. 2x10" wooden joists, 16"o.c. 2. 1 11/32" tongue and groove wood-fiber board. 3. 44 oz. wool carpet on 40 oz. hair pad. 4. Resilient channels, 24"o.c. 5. 5/8" gypsum screwed 12"o.c. | 49 (68) |
|  | <ol style="list-style-type: none"> 1. 2x10" wooden joists, 16"o.c. 2. 19/32" tongue and groove plywood. 3. <ol style="list-style-type: none"> a. Carpet and pad. b. Vinyl tile. 4. Resilient channels, 24"o.c. 5. 5/8" gypsum screwed 12"o.c. 6. 1" thick sound attenuation blanket. | 51 (a. 74) (b. 51) |

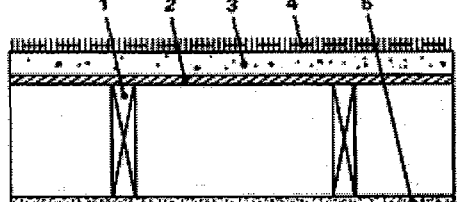
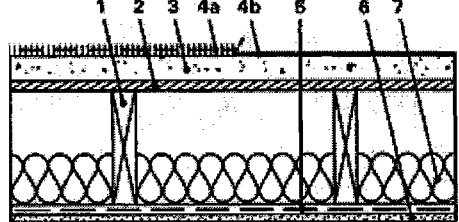
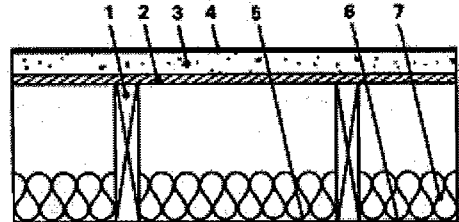
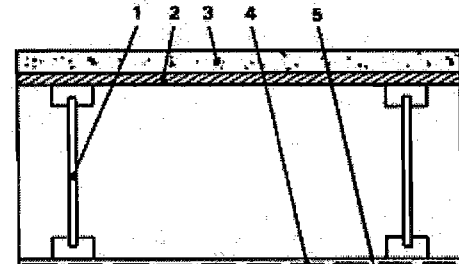

| Sketch | Brief Description | STC (IIC) |
|---|---|---|
|  | <ol style="list-style-type: none"> 1. 2x10" wooden joists, 16"o.c. 2. 1 11/32" tongue and groove wood-fiber board. 3. 40 oz. wool carpet on 80 oz. sponge rubber pad. 4. Resilient channels, 24"o.c. 5. 1/2" gypsum board screwed 12"o.c. 6. 3" thick sound attenuation blanket. | 50 (72) |
|  | <ol style="list-style-type: none"> 1. 2x10" wooden joists, 16"o.c. 2. 5/8" plywood sub floor glued to joists, nailed with 8d nails 12"o.c. 3. 1/4" particleboard glued to plywood. 4. 1/2" parquet wood flooring glued to particleboard. 5. 1/2" type-X gypsum board screwed 12"o.c. 6. 3" thick sound attenuation blanket. | 43 (NA) |
|  | <ol style="list-style-type: none"> 1. 2x10" wooden joists, 16"o.c. 2. 5/8" tongue and groove plywood nailed with 8d nails 6"o.c. along edges and 10"o.c. in field. 3. Two layers of 5/8" gypsum board attached with screws 12"o.c. to underside of sub floor. 4. <ol style="list-style-type: none"> a. 44 oz. carpet on 40 oz. hair pad. b. 1/16" vinyl asbestos tile. 5. Resilient channels, 24"o.c. 6. 5/8" gypsum board screwed 12"o.c. 7. 3 1/2" thick sound attenuation blanket. | 56 (a. 74) (b.50) |
|  | <ol style="list-style-type: none"> 1. 2x10" wooden joists, 16"o.c. 2. 5/8" tongue and groove plywood nailed with 8d nails 6"o.c. along edges and 10"o.c. in field. 3. <ol style="list-style-type: none"> a. 44 oz. carpet on 40 oz. hair pad. b. 1/16" vinyl asbestos tile. 4. 5/8" gypsum board nailed 7"o.c. 5. Two layers of 5/8" gypsum board suspended by wire hangers 5" long in a 2x4' heavy-duty T grid ceiling system. 6. 3 1/2" thick sound attenuation blanket. | 49 (a. 68) (b.47) |

| Sketch | Brief Description | STC (IIC) |
|---|--|------------------------------|
|  | <ol style="list-style-type: none"> 1. 2x8" wooden joists, 16"o.c. 2. 5/8" tongue and groove plywood nailed to joists with 8d nails 6"o.c. at edges and 10"o.c. in field. 3. 1 5/8" lightweight concrete over 4 mil. polyethylene film. 4. 44 oz. carpet on 40 oz. hair pad. 5. 5/8" gypsum board nailed to joists. | 47 (66) |
|  | <ol style="list-style-type: none"> 1. 2x8" wooden joists, 16"o.c. 2. 5/8" tongue and groove plywood nailed to joists with 8d nails 6"o.c. at edges and 10"o.c. in field. 3. 1 5/8" thick lightweight concrete over 4 mil. polyethylene film. 4. <ol style="list-style-type: none"> a. 44 oz. carpet on 40 oz. hair pad. b. .075" sheet vinyl. 5. Resilient channels, 24"o.c. 6. 5/8" gypsum board screwed 12"o.c. 7. 3" thick sound attenuation blanket. | 53 (a. 74) (b. 47) |
|  | <ol style="list-style-type: none"> 1. 2x10" wooden joists. 16"o.c. 2. 5/8" plywood nailed to joists. 3. 1 1/2" thick lightweight concrete, 13 psf. 4. Cushioned vinyl. 5. Resilient channels, 24"o.c. 6. 5/8" gypsum board screwed to channels. 7. 3 1/2" thick sound attenuation blanket. | NA (51) |
|  | <ol style="list-style-type: none"> 1. Plywood web I-beams 12" deep and 24"o.c. 2. 3/4" plywood sub floor nailed with 6d nails 6"o.c. at edges and 10"o.c. in field. 3. 1 1/2" thick lightweight concrete, 15 psf. 4. Resilient channels, 24"o.c. 5. 5/8" gypsum board screwed 12"o.c. | 57 (NA) |

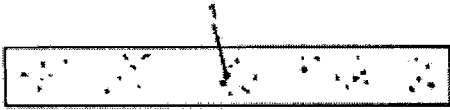
| Sketch | Brief Description | STC (IIC) |
|--------|--|------------------------------|
| | <ol style="list-style-type: none"> 1. Plywood web I-beams 12" deep and 24" o.c. 2. 3/4" plywood sub floor nailed with 6d nails 6" o.c. at edges and 10" o.c. in field. 3. 1 1/2" thick lightweight concrete, 15 psf. 4. <ol style="list-style-type: none"> a. 44 oz. carpet on 40 oz. hair pad. b. .07" vinyl tile. 5. Resilient channels, 24" o.c. 6. 5/8" gypsum board screwed 12" o.c. 7. 3" thick sound attenuation blanket. | 58 (a. 77) (b. 50) |
| | <ol style="list-style-type: none"> 1. 2x10" wooden joists, 16" o.c. 2. 5/8" plywood glued to joists, nailed with 8d nails 12" o.c. 3. 1/4" particleboard glued to plywood. 4. 1/2" fiberboard glued to particleboard. 5. <ol style="list-style-type: none"> a. 76 oz. carpet on 50 oz. hair pad. b. 1/2" parquet wood flooring. 6. Resilient channels, 24" o.c. 7. 1/2" type-X gypsum board screwed 12" o.c. 8. 3" thick sound attenuation blanket. | 51 (NA) |
| | <ol style="list-style-type: none"> 1. 2x10" wooden joists, 16" o.c. 2. 5/8" plywood sub floor nailed with 8d nails 6" o.c. along edges, 10" o.c. in field. 3. 1 1/2" thick lightweight concrete over 15 lb. asphalt felt. 4. <ol style="list-style-type: none"> a. 20 oz. carpet on 40 oz. hair pad. b. 1/16" thick vinyl-asbestos tile. 5. Resilient channels, 24" o.c. 6. 1/2" type-X gypsum board screwed 12" o.c. | 56 (NA) |
| | <ol style="list-style-type: none"> 1. 2x10" wooden joists, 16" o.c. 2. 5/8" plywood sub floor nailed with 8d nails 6" o.c. along edges, 10" o.c. in field. 3. 1 1/2" thick lightweight concrete over 15 lb. asphalt felt. 4. <ol style="list-style-type: none"> a. 20 oz. carpet on 40 oz. hair pad. b. 1/16" thick vinyl-asbestos tile. 5. Resilient channels, 24" o.c. 6. 5/8" type-X gypsum board screwed 12" o.c. 7. 3 1/2" thick sound attenuation blanket. | 61 (NA) |

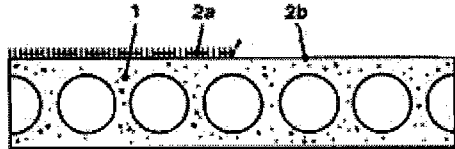
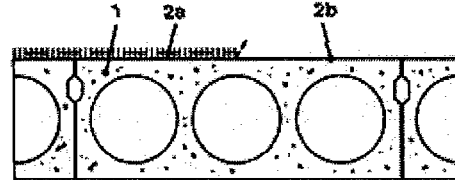
FLOORS: Concrete

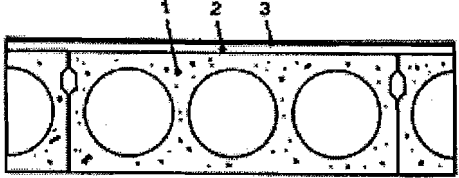
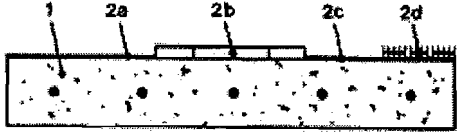
| Sketch | Brief Description | STC (IIC) |
|---|--|--------------------------|
|  | <ol style="list-style-type: none"> 1. 4" thick concrete slab, 54 psf. | 44 (25) |
|  | <ol style="list-style-type: none"> 1. 6" thick concrete slab, 75 psf. | 55 (34) |
|  | <ol style="list-style-type: none"> 1. 6" thick concrete slab. 2. 1/2" wood-fiber board glued to concrete. 3. 44 oz. carpet on 40 oz. hair pad. | NA (81) |
|  | <ol style="list-style-type: none"> 1. 6" thick hollow-core concrete panel, 45 psf. 2. <ol style="list-style-type: none"> a. Carpet and pad. b. No floor covering. | 48 (a. 69) (b. 23) |
|  | <ol style="list-style-type: none"> 1. 8" thick hollow-core concrete panel, 57 psf. 2. <ol style="list-style-type: none"> a. 66 oz. carpet on 50 oz. hair pad. b. No floor covering. | 50 (a. 74) (b. 28) |

| Sketch | Brief Description | STC (IIC) |
|---|--|---|
|  | <ol style="list-style-type: none"> 1. 8" thick hollow-core concrete panels, 57 psf. 2. 1/4" inorganic felt-supported underlayment board, .6 psf. 3. 3/32" vinyl-asbestos tile. | 50 (51) |
|  | <ol style="list-style-type: none"> 1. 3" thick reinforced concrete slab, 35 psf, ceiling bare. 2. <ol style="list-style-type: none"> a. Vinyl asbestos, 0.08" thick. b. Wood parquet 1/2" thick. c. Soft vinyl tile with foam plastic backing. d. Carpet over soft padding, at least 1/4" thick. | 45 (a. 42) (b.45) (c. 49) (d. 70) |
|  | <ol style="list-style-type: none"> 1. 3" thick reinforced concrete slab, 35 psf. 2. <ol style="list-style-type: none"> a. Wood parquet 1/2" thick. b. Soft vinyl tile with foam plastic backing. c. Carpet over soft padding, at least 1/4" thick. 3. Resilient furring channels on 1/2" fiberglass blanket. 4. 1/2" gypsum board. | 56 (a.51) (b. 55) (c. 70) |

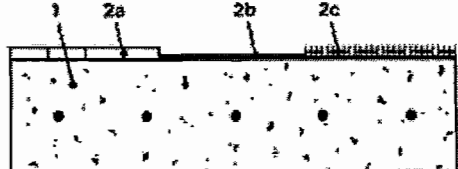
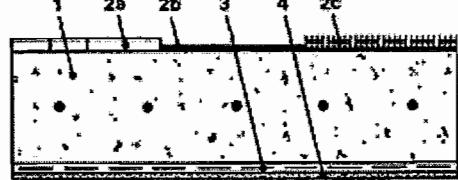
| Sketch | Brief Description | STC (IIC) |
|---|--|---|
|  | <ol style="list-style-type: none"> 1. 5" thick reinforced concrete slab, 55 psf. ceiling bare. 2. <ol style="list-style-type: none"> a. Wood parquet 1/2" thick. b. Soft vinyl tile with foam plastic backing. c. Carpet over soft padding, at least 1/4" thick. | 51 (a. 46) (b. 50) (c. 70) |
|  | <ol style="list-style-type: none"> 1. 5" thick reinforced concrete slab, 55 psf. 2. <ol style="list-style-type: none"> a. Wood parquet 1/2" thick. b. Soft vinyl tile with foam plastic backing c. Carpet over soft padding, at least 1/4" thick. 3. Resilient furring channels on 1/2" fiberglass blankets. 4. 1/2" gypsum board. | 56 (a. 51) (b. 55) (c. 75) |

WINDOWS

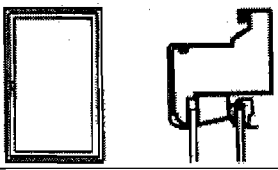
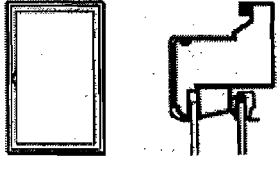
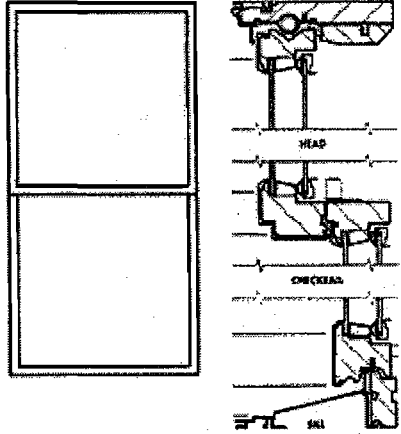
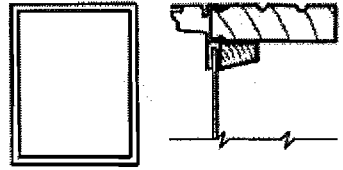
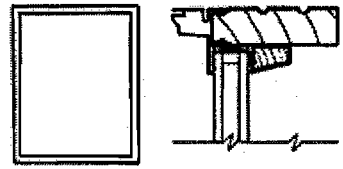
| Sketch Front / Cross Section | Brief Description | STC |
|---|---|-----|
|  | 30x48" aluminum clad casement, two 1/8" panels of glass, 13/16" apart in a wood frame. | 29 |
|  | 30x48" aluminum clad casement, one 3/32" panel and one 1/8" panel, 13/16" apart in a wood frame. | 31 |
|  | 32x24x24" aluminum double-hung windows (32" wide with 24" high upper sash and a 24" high lower sash), each sash has one 3/32" panel and one 1/8" panel, 13/16" apart in a wood frame. | 29 |
|  | 6x5' picture window glazed double strength, single panel. | 29 |
|  | 6x5' picture window plus storm sash, glazed double strength single panel, 3 3/4" separation between panels. | 38 |

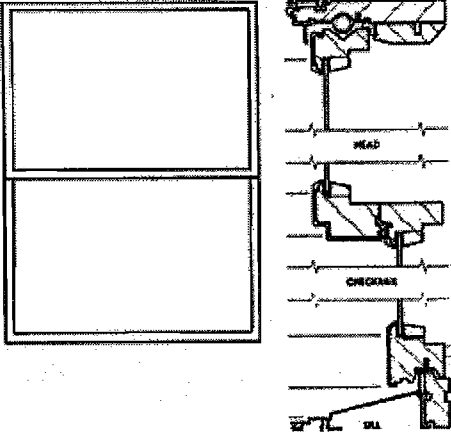
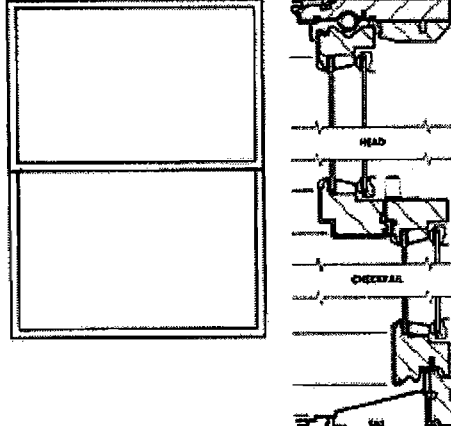
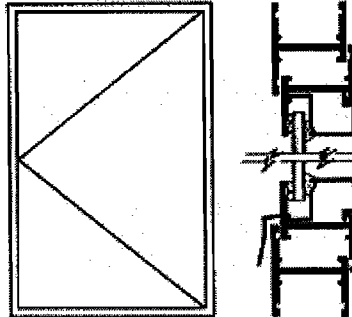
| Sketch Front / Cross Section | Brief Description | STC |
|---|---|-----------|
|  | <p>3x5' double hung window, 7/16" glazed insulating glass, single panel.</p> | <p>26</p> |
|  | <p>3x5' double hung window, 7/16" glazed insulating glass, single panel plus storm sash, glazed single strength, single sealed separation between panels: upper 1 1/2", lower 2 13/16".</p> | <p>35</p> |
|  | <p>3x4' awning window, glazed double strength, cranked shut.</p> | <p>24</p> |

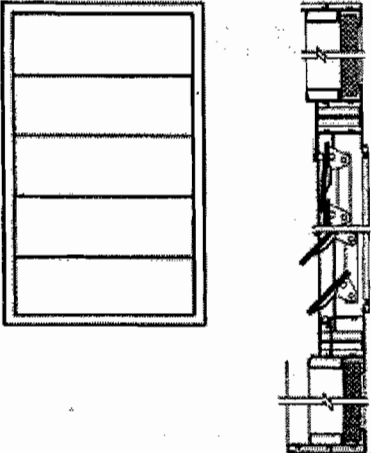
| Sketch Front / Cross Section | Brief Description | STC |
|---|---|-----|
|  | <p>3x4' jalousie window, glazed 1/4" glass, 4 1/2" wide louvers with 1/2" in overlap, cranked tight shut.</p> | 20 |

DOORS: Exterior

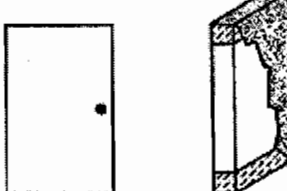
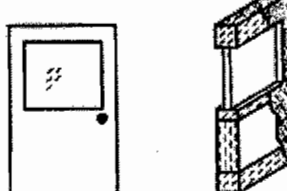
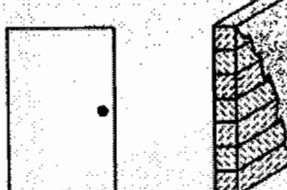
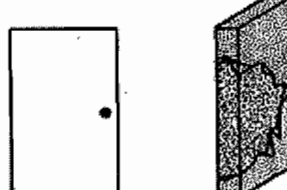
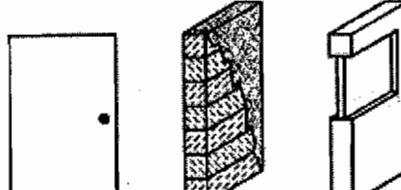
| Sketch Front / Cross Section | Brief Description | STC |
|---|--|-----|
|  | 3x7' hollow-core wood door, 1 3/4" thick. | 20 |
|  | 3x7' hollow-core door, 1 3/4" thick, 30% of area glazed with 1/8" glass. | 19 |
|  | 3x7' solid-core wood door, 1 3/4" thick. | 27 |
|  | 3x7' steel-faced door, 1 3/4" thick, rigid polyurethane core. | 26 |
|  | 3x7' solid-core wood door, 1 3/4" thick plus an aluminum storm door, glazed single strength. | 34 |

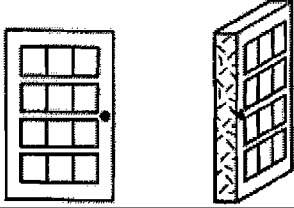
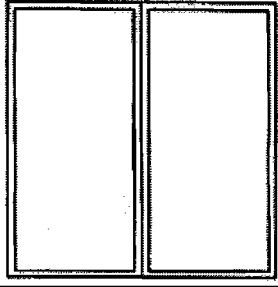
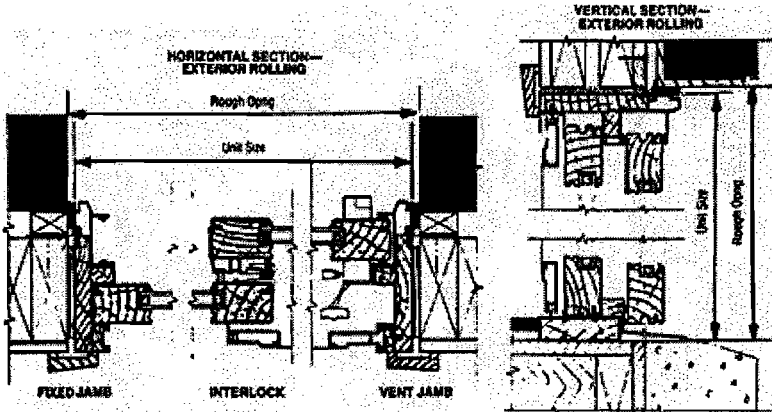
| Sketch Front / Cross Section | Brief Description | STC |
|---|---|-----------|
|  | <p>3x7' wood French door, 12 lights glazed single strength, mounted in frame, brass weather strip.</p> | <p>26</p> |
|  | <p>6x6' sliding glass doors, 3/4" insulating glass (2 pieces 1/8" tempered glass), one door opens, other is permanent in place.</p> | <p>28</p> |
|  | | |
| <p>*All exterior doors are sealed with a weathering strip around the frame. Interior doors do not have a weather strip and are not flush to the floor to permit the installation of a carpet.</p> | | |

DOORS: Interior

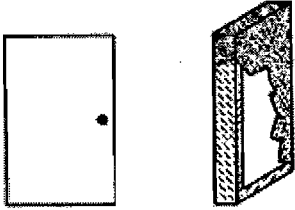
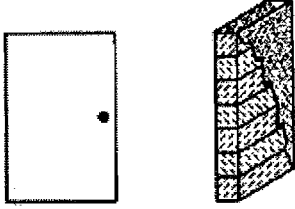
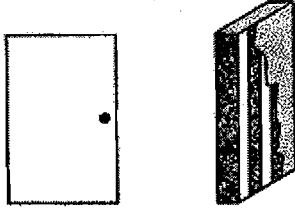
| Sketch Front / Cross Section | Brief Description | STC |
|---|---|-----|
|  | <p>3x7' solid-core wood door, 1 3/4" thick, weight 1.5 lb/ft².</p> | 17 |
|  | <p>3x7' solid-core wood door, 1 3/4" thick, weight 4.0 lb/ft².</p> | 20 |
|  | <p>3x7' hollow-core steel door, 1 3/4" thick, weight 5.0 lb/ft².</p> | 17 |

Appendix B References

Appendix B

General References

Books:

Acoustical and Thermal Performance of Exterior Residential Walls. Doors and Windows; NBS Building Science Series 77, U.S. Department of Commerce/National Bureau of Standards, 1975.

Acoustics Noise and Buildings; Parkin, Humphreys and Cowell; Faber and Faber; London; 1979.

Airborne Sound Transmission Loss, Characteristics of Wood Frame Construction; Fred F. Rudder, Jr.; USDA, Forest Service; General Technical Report FPL-43.

Handbook of Architectural Acoustics and Noise Control; Michael Retting; Tab Book; Blue Ridge Summit, Pa.; 1979.

Quieting: A Practical Guide to Noise Controls; U.S. Department of Commerce/National Bureau of Standards; NBS Handbook 119; 1976.

Institutions and Organizations:

Amerada Architectural Glass.

DeSco Windows.

Georgia-Pacific.

Industrial Acoustics Company.

National Concrete Masonry Association.

Office of Noise Control; California Department of Health Services.

Overly Manufacturing Company.

Paella Products.

Portland Cement Association.

U.S. Gypsum Company.

Testing Laboratories:

Cedar Knolls Acoustical Laboratories.

Geiger and Hamme.

Kaiser Gypsum.

Kodaras Acoustical.

National Institute of Standards and Technology.

National Research Council of Canada.

Riberbank Acoustical Laboratories.

ERRATA SHEET

The Noise Guidebook
Railway Noise Guidance and Calculation Corrections

February 2009

The following should replace the paragraph entitled "Horns and Whistles" on page 63 (also marked 15) in the Noise Assessment Guidelines, Chapter 5, of *The Noise Guidebook* (September 1991).

If the Noise Assessment Location (NAL) is perpendicular to any point on along a railroad track between the whistle posts for a road crossing, a factor to account for the noise of warning horns or whistles must be included in the calculation. There are 2 factors to be used based on the type of locomotive. If the locomotive is diesel-powered, enter the number 10 in column 11 of Worksheet D. If the locomotive is electric-powered, enter the number 100 in column 18 of Worksheet D. If the NAL is not between the whistle posts for a road crossing, enter the number 1 in each column.

Note: Whichever horn factor is appropriate, it must only be applied once. If a factor is applied for diesel locomotives in the first section of the worksheet, it must not be applied to the railcar noise calculation in the second part. In that instance, enter the number 10 in column 11 and the number 1 in column 18.

A revised Worksheet D also accompanies this correction. It is easily distinguished from the original. The new Worksheet D has an additional column in the second section of page 2 for a total of 27 columns. The original version, with 26 columns, is hereby void.

**Railway Noise
Data Sheet**

Noise Assessment Guidelines

List All Railways within 3000 feet of the site:

Notes

1. _____

2. _____

3. _____

Necessary Information

Railway No. 1

Railway No. 2

Railway No. 3

1. Effective distance: _____

Measured in feet from
NAL to center of track

2. Number of Trains in 24 hours:

a. diesel _____

b. electrified _____

3. Fraction of operations occurring at night: _____

10 p.m. - 7a.m.

4. Number of diesel locomotives per train: _____

5. Number of rail cars per train:

a. diesel trains _____

b. electrified trains _____

Include locomotive for
electrified trains

6. Average train speed: _____

7. Is track welded or bolted? _____

8. Is the site opposite a section of tracks
between whistle stops? _____

**Railway Noise
Computations and Findings**

Noise Assessment Guidelines

Adjustments for Diesel Locomotives

| | 9 No. of Locomotives 2 | 10 Average Speed (Table 9) | 11 Horns (Enter 10) | 12 Night- time (Table 5) | 13 No. of Trains (Line 2a) | 14 Adj. No of Opns. | 15 DNL (Workchart 3) | 16 Barrier Attn. | 17 Partial DNL |
|---------------|---------------------------------|-------------------------------------|---------------------------|-----------------------------------|-------------------------------------|---------------------------|----------------------------|------------------------|----------------------|
| Railway No. 1 | _____ x _____ | x _____ | x _____ | x _____ | x _____ | = _____ | _____ - _____ | = _____ | |
| Railway No. 2 | _____ x _____ | x _____ | x _____ | x _____ | x _____ | = _____ | _____ - _____ | = _____ | |
| Railway No. 3 | _____ x _____ | x _____ | x _____ | x _____ | x _____ | = _____ | _____ - _____ | = _____ | |

Adjustments for Railway Cars or Rapid Transit Trains and Electric Locomotives

| | 18 Horns on Electric Trains only (Enter 100) | 19 Number of cars 50 | 20 Average Speed (Table 10) | 21 Bolted Rails (Enter 4) Welded (Enter 1) | 22 Night- time (Table 5) | 23 No. of Trains (Lines 2a and 2b) | 24 Adj. No. of Opns. | 25 DNL (Workchart 4) | 26 Barrier Attn. | 27 Partial DNL |
|---------------|--|-------------------------------|--------------------------------------|---|-----------------------------------|--|----------------------------|----------------------------|------------------------|----------------------|
| Railway No. 1 | _____ x _____ | x _____ | x _____ | x _____ | x _____ | x _____ | = _____ | _____ - _____ | = _____ | |
| Railway No. 2 | _____ x _____ | x _____ | x _____ | x _____ | x _____ | x _____ | = _____ | _____ - _____ | = _____ | |
| Railway No. 3 | _____ x _____ | x _____ | x _____ | x _____ | x _____ | x _____ | = _____ | _____ - _____ | = _____ | |

Combined Locomotive and Railway Car DNL (See combining noise levels table for procedures)

| | | | | | | | |
|------------------------------|-------|------------------------------|-------|------------------------------|-------|---|-------|
| Partial DNL Railway No. 1 | _____ | Partial DNL Railway No. 2 | _____ | Partial DNL Railway No. 3 | _____ | Partial DNL Total DNL for all Railways | _____ |
|------------------------------|-------|------------------------------|-------|------------------------------|-------|---|-------|

Signed _____ Date _____

